

EXTENDING THE THEORY OF RANDOM SURFACES

Thesis by

Christof Schmidhuber

In Partial Fulfillment of the Requirements

for the Degree of

Doctor of Philosophy

California Institute of Technology

Pasadena, California

1993

(submitted May 14, 1993)

© 1993

by Christof Schmidhuber

All Rights Reserved

Acknowledgements

Being around people who share my enthusiasm for doing physics has made me feel very much at home on the fourth floor of Lauritsen. I thank Steve Frautschi, John Preskill, John Schwarz, Mark Wise, Anna, David and David, Dimitris, Helen, Jerry, Keke, Malik, Martin, Ming, Phil, Pil, Rob, Sandip and Wolfgang for the very friendly atmosphere that has made it a pleasure to come to work.

I am particularly grateful to my advisor John Schwarz, for never hesitating to support me with help and advice when I had plans or ideas that I wanted to carry out, and for his encouragement that gave me confidence in times when nothing seemed to work. I also thank Keke Li for listening to my ideas and my confusions and for his efforts to keep my feet on the ground.

Needless to say, my Caltech years would not have been as much fun without occasionally extending campus to anywhere between Mount Denali and Lake Titicaca, together with Zhaoping, Ojvind, Thomas and the others. And last but not least, I am happy that the distance to my family and my friends back home has remained purely geographical.

Abstract

The theory of embedded random surfaces, equivalent to two-dimensional quantum gravity coupled to matter, is reviewed, further developed and partly generalized to four dimensions. It is shown that the action of the Liouville field theory that describes random surfaces contains terms that have not been noticed previously. These terms are used to explain the phase diagram of the Sine-Gordon model coupled to gravity, in agreement with recent results from lattice computations. It is also demonstrated how the methods of two-dimensional quantum gravity can be applied to four-dimensional Euclidean gravity in the limit of infinite Weyl coupling. Critical exponents are predicted and an analog of the “ $c = 1$ barrier” of two-dimensional gravity is derived.

CONTENTS

Introduction	1
Part I : Review of Previous Work on Random Surfaces	3
1. Random Surfaces and Random Walks	3
2. 2D Gravity in Conformal Gauge	8
3. The Trace Anomaly and DDK	12
4. Applied Liouville Theory	20
Appendix: Random Lattices and Matrix Models	28
Part II : Running Coupling Constants in 2D Gravity	34
1. Introduction	34
2. Exactly Marginal Operators	36
3. Running Coupling Constants	42
4. Outlook	47
Appendix A: Boundary Conditions	49
Appendix B: The Cosmological Constant	52
Part III : A 4D Analog of 2D Gravity	54
1. Introduction	54
2. Conformal Gauge	57
3. Liouville in 4D	59
4. DDK in 4D	61
5. Results	67
6. Weyl Gravity at Short Distances	70
References	73

Introduction

Like random walks, random surfaces appear in many physical systems – in statistical mechanics, in QCD, in string theory and in other fields. But while random walks embedded in any number of dimensions have long been well-understood, only in recent years has there been much progress on random surfaces. The most striking development has been the “matrix model” – a gedanken experiment that has yielded numerical values for critical coefficients and correlation functions.

Unfortunately, this method is restricted to random surfaces embedded in $D \leq 1$ dimensions. From the point of view of physics, the models with $D \leq 1$ are not interesting by themselves. The physically interesting models involve either higher embedding dimensions – $D = 3$ for the theory of phase transitions, $D = 4$ for QCD, $D = 26$ and $D = 10$ for string theory and superstring theory – or world-sheet dimension four instead of two, if one thinks of the theory of random geometries as quantum gravity.

It is therefore necessary to develop a field theory of random surfaces that can be generalized to these cases. What makes the models with $D \leq 1$ interesting is their role as ideal laboratories for testing such a theory – ideal precisely because the answers are known from the matrix models.

Although major progress in this direction has recently been made by David, Distler and Kawaii, this theory is still incomplete even for $D \leq 1$. Thus there are presently two challenges: on the one hand, our understanding of the matrix model results from the continuum approach must be completed. On the other hand, this continuum approach must be extended to the physically interesting cases mentioned above.

This double challenge is reflected in this work. Part II fills a gap in the continuum theory of random surfaces in $D \leq 1$ dimensions, while part III begins generalizing this theory to four dimensions.

To provide the necessary background, previous developments in the theory of random surfaces are summarized in part I. Based on its formulation as two-dimensional quantum gravity coupled to matter, the theory is discussed in conformal gauge. The conformal anomaly, the Liouville action, the proposal of David, Distler and Kawai, the computation of critical coefficients and the spectrum of states are reviewed. A brief introduction to random lattices and matrix models is given in the appendix.

In part II, it is shown that the action for two-dimensional quantum gravity coupled to interacting matter contains certain terms that have not been noticed previously. They are crucial for understanding the renormalization group flow, and can be observed in recent matrix model results for the phase diagram of the Sine-Gordon model coupled to gravity. These terms ensure, order by order in the coupling constant of the interaction, that the theory is scale invariant. They are discussed up to second order.

In part III, it is asked in how far the methods of two-dimensional quantum gravity can be applied to four-dimensional gravity. It is found that they can be applied to Weyl gravity at its ultraviolet fixed point of infinite Weyl coupling. There, the path integral over geometries reduces to integrals over the conformal factor and over the moduli space of conformally self-dual metrics. The conformal anomaly induces an analog of the Liouville action. The proposal of David, Distler and Kawai is generalized to four dimensions. Critical exponents are predicted and the analog of the $c = 1$ barrier of two-dimensional gravity is derived.

PART I: REVIEW OF PREVIOUS WORK ON RANDOM SURFACES

1. Random Surfaces and Random Walks

1.1. The Problem

The topic of Part I is the sum over embeddings of closed, compact, euclidean two-dimensional surfaces in D -dimensional space:

$$\int \frac{\mathcal{D}x^i(\sigma)}{\text{Diff}} e^{-S}, \quad S \sim \text{area} + \text{other geometrical quantities.} \quad (1.1)$$

Here, $\sigma \equiv (\sigma_1, \sigma_2)$ parametrizes the surface and the x^i parametrize the embedding space. “Diff” in the denominator indicates that the sum is over embeddings modulo diffeomorphisms,^{*} i.e., over “geometries”. Since such geometries are the two-dimensional analogues of continuous random walks, they are called “random surfaces”. For random walks, σ in (1.1) would be a single parameter, and the leading term in the action S would be proportional to the length of the walk.

Instead of summing over closed surfaces in (1.1), corresponding to closed random walks, we could sum over surfaces with some boundary cycles that are fixed in the embedding space. This would be the analog of random walks going from some point A to some point B . Unfortunately, the theory of random surfaces with boundaries is presently not well-developed, so we will mostly concentrate on the sum over closed surfaces below.

Unlike closed paths, closed surfaces can have different topologies. This is one of the difficulties one encounters when studying random surfaces – it is more like studying interacting random walks (see fig. 1). For the most part, we will concentrate on surfaces of spherical topology below, although some things will be said about the sum over topologies.

^{*} coordinate transformations on the surface

1.2. The Motivation

Why do we want to study the sum (1.1) in the first place? Like random walks, random surfaces have many interesting applications and a better understanding of them will benefit diverse areas of physics. Here are some examples of where random surfaces occur:

They appear in the low-temperature expansion of three-dimensional statistical mechanical systems, like the Ising model, as boundaries between regions of different phases. Or, the perturbation expansion of large- N QCD can be summed in terms of surfaces of different topology. The theory of random surfaces embedded in D dimensions is also equivalent to two-dimensional quantum gravity coupled to D bosons and thus provides a simple toy model for problems in quantum gravity. Surely there is little hope of understanding quantum gravity in four dimensions, whatever it may be, before one understands the much simpler two-dimensional case.

Perhaps most interestingly, the theory of random surfaces is string theory in first-quantized formulation, just like the theory of interacting random walks is first-quantized ϕ^4 theory (fig. 1). Summing random surfaces is equivalent to summing the string perturbation expansion and could even lead to nonperturbative predictions of string theory as a theory of the fundamental interactions including gravity.

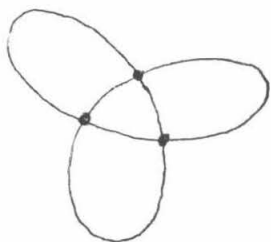

Fig. 1a: A closed path, or
4-loop vacuum diagram of ϕ^4 theory



Fig. 1b: A closed surface, or
4-loop vacuum diagram of string theory

1.3. Outline

We begin with an outline of the following introduction, and of what makes random surfaces more difficult than random walks. There are two ways to perform the sum (1.1): Either one discretizes the random surfaces as random triangulations and tries to sum all distinct triangulations (fig. 2), or one attempts to do the path integral using field theory.

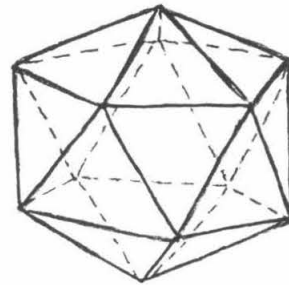
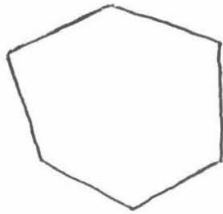

Fig. 2a: A discretized random walk

Fig. 2b: A discretized random surface

The first way is actually the more powerful one. Amazingly, random triangulations can be summed with the help of the matrix model trick,^[1] explained in the appendix: they are in one-to-one correspondence with the Feynman diagrams of a theory of $N \times N$ -matrices in the large N limit. For embedding dimensions $D \leq 1$ ^{*} this “matrix model” can be solved exactly, yielding critical exponents and correlation functions. In this way one can even sum over all possible topologies of the surfaces.

However, while the matrix model yields results, it offers little understanding of how they arise, and it is restricted to unphysical embedding dimensions. One would like to have a field theory describing random surfaces, that can be generalized to the more physical cases in which no matrix models are available. These include surfaces

^{*} The meaning of noninteger or negative D will be explained below.

embedded in 3, 4 and 26 dimensions, super-surfaces, and four-dimensional “surfaces.” For this reason the emphasis in this review will be on the continuum approach. The matrix model will be viewed as a numerical “experiment” whose results allow us to check the field theory description.

To develop such a description, it is best to rewrite (1.1) as two-dimensional quantum gravity coupled to D scalar fields,^[2] as will be explained in section 2. Likewise, the random walk can be interpreted as one-dimensional quantum gravity coupled to D scalar fields, but is much more trivial: one-dimensional geometries are labeled by only one diffeomorphism invariant parameter – their total length. They have no dynamics and the resulting theory is just D -dimensional quantum mechanics.

Two-dimensional geometries are best parametrized in conformal gauge, by the conformal factor $\phi(\sigma)$, some moduli parameters and the genus. This is also done in section 2 and leads to a theory of $D + 1$ two-dimensional fields, the x 's and ϕ . As a field theory, it has features that have no analogy in the case of the random walk. The most important one is the conformal anomaly: one might think that two-dimensional gravity is also trivial, in the sense that the Hilbert–Einstein action is a topological invariant and the cosmological constant provides no dynamics for the geometries. But as will be seen in section 3, the conformal anomaly induces dynamics for ϕ , forcing us to study the Liouville action,^[3]

$$\int d^2\sigma ((\partial\phi)^2 + \mu e^{\alpha\phi}).$$

The reformulation of two-dimensional quantum gravity as an ordinary field theory involving the Liouville action was a big step forward, due to David,^[4] Distler and Kawai^[5] (DDK) and also reviewed in section 3. The most important feature of this theory is its background independence, reflecting general covariance of the original theory. However, since Liouville theory is notoriously difficult to deal with, this approach is not yet as powerful as the matrix model methods mentioned above. In particular, it is not known how to sum over topologies. Some aspects of Liouville theory are reviewed in section 4 and some results are extracted.

The continuum approach reveals a transition to a branched polymer phase when the embedding dimension exceeds 1. The interesting case $D = 1$, a main topic of part II, is also briefly discussed in section 4. The review closes with a brief exposition of matrix model ideas in the appendix.

1.4. Further Problems

As emphasized, random surfaces embedded in $D \leq 1$ dimensions are not physically interesting by themselves. Rather, these models should be used as testing grounds in which a continuum theory of random surfaces can be developed, checked with the help of the matrix model results and then generalized to the physical cases.

For example, after understanding quantum gravity in one and two dimensions (random walks and random surfaces), one would like to go on and understand Euclidean quantum gravity in four dimensions. A first step towards this is taken in Part III. There, it is shown how to generalize the above methods to four dimensions in the limit of infinite Weyl coupling.

Even the theory of random surfaces in $D \leq 1$ dimensions is not yet complete. For example, in DDK's approach, background independence has been imposed only to lowest order, in a sense that will be explained. Imposing it to next order also has important consequences, as will be seen in Part II.

Another important gap in the present theory is that we do not know how to sum over topologies in the continuum approach. We know from the matrix models that the result is simple and beautiful, given by the KdV hierarchy. This might be a hint that there is a simple method to perform this sum. If such a method exists and can be generalized to the physically interesting cases, the consequences could be far-reaching: one might be able to do nonperturbative string theory or nonperturbative QCD in the framework of first quantized random surfaces. Or one might be able to study more rigorously the effects of wormholes in four dimensions and their relevance, e.g., for the cosmological constant problem. Many other applications can be thought of. This must be left for future research.

2. 2D Gravity in Conformal Gauge

2.1. Random Surfaces and 2D Gravity

It is well-known that, instead of the integral (1.1), one may study the equivalent path integral for quantum gravity in two dimensions coupled to D scalar fields x^i .^[2] The partition function is

$$\begin{aligned} Z &= \int \frac{\mathcal{D}g_{\alpha\beta}}{\text{Diff}} \mathcal{D}x^i e^{-S[g,x]} \quad \text{with} \\ S &= \int d^2\sigma \sqrt{g} \{ \mu + \gamma R + g^{\alpha\beta} \partial_\alpha x^k \partial_\beta x_k + \text{other covariant terms} \}. \end{aligned} \quad (2.1)$$

Here, $g_{\alpha\beta}$ is the two-dimensional metric, “Diff” again indicates that we divide the diffeomorphism group out, R is the Ricci scalar, and μ and γ are the cosmological and inverse Newtonian constants. To see that (1.1) and (2.1) are equivalent is not trivial. One first considers the case $\mu = \gamma = 0$ and notes that (1.1) and (2.1) are equivalent at the classical level: The equations of motion for $g_{\alpha\beta}$ are

$$\partial_\alpha \vec{x} \cdot \partial_\beta \vec{x} = \frac{1}{2} g_{\alpha\beta} \partial_\alpha \vec{x} \cdot \partial^\alpha \vec{x}.$$

The solution is

$$\partial_\alpha \vec{x} \cdot \partial_\beta \vec{x} = g_{\alpha\beta}, \quad \text{so} \quad S = \int d^2\sigma \sqrt{g} = \int d^2\sigma |\det \partial_\alpha \vec{x} \cdot \partial_\beta \vec{x}|^{1/2} \quad (2.2)$$

is a saddle point of the action. $g_{\alpha\beta}$ at the saddle point is the embedding space metric induced on the surface, since

$$ds^2 = dx^k dx_k = \partial_\alpha x^k d\sigma^\alpha \partial_\beta x_k d\sigma^\beta = g_{\alpha\beta} d\sigma^\alpha d\sigma^\beta, \quad (2.3)$$

so the saddle point action (2.2) is the area as in (1.1). It is known as the Nambu–Goto action. It can then be shown that quantum corrections are also of the form (2.2), so that integrating out g in (2.1) yields (1.1). For $\mu \neq 0$, (2.1) has no saddle point. Nevertheless the equivalence of (2.1) and (1.1) can be seen to hold. We refer to ref. [2] for details.

The notion of embedded random surfaces can now be generalized to noninteger embedding dimensions by coupling any conformally invariant matter theory to gravity, not only scalars x^i . The natural definition of D is then the “central charge” c of the matter theory, which will be introduced below. It is 1 for each free scalar, 1/2 for each free fermion and can be negative for nonunitary theories.

In (2.1) we could include other renormalizable terms in the action, like

$$g_{kl}(x)\partial_\alpha x^k \partial^\alpha x^l, \quad T(x)$$

with arbitrary analytic functions $g_{kl}(x)$, $T(x)$. The first term corresponds to random surfaces embedded in curved space. But let us start with the terms written out in (2.1) and add interactions of x later.*

The Hilbert–Einstein action in (2.1) is a topological invariant, the Euler characteristic χ :

$$\chi = \frac{1}{4\pi} \int d^2\sigma \sqrt{g} R = 2 - 2g, \quad (2.4)$$

where g is the genus, or number of handles, of the surface. Thus, the expansion of (2.1) in terms of the “string coupling constant” $\lambda = \exp\{4\pi\gamma\}$ is a topological expansion: surfaces with g handles are weighted with a relative factor λ^{2g} .

2.2. Conformal Gauge

The form (2.1) of the integral is much more convenient than the form (1.1), because the area expressed in terms of x , as in (2.2), is difficult to handle. Also dividing out the diffeomorphism group is difficult in (1.1). So we will simplify (2.1) in the next two sections. First, consider the sum over metrics modulo diffeomorphisms. It is most convenient to parametrize them in conformal gauge. To this end, let us recall the following well-known facts:^[7]

* We will not discuss the extrinsic curvature^[2] here.

1. The topology of a closed, oriented surface is completely specified by the genus g in (2.4).

2. Two metrics are said to be in the same conformal equivalence class, if they differ only by a rescaling and a diffeomorphism. For given genus, there is a finite dimensional moduli space of conformal equivalence classes. Its dimension is zero for the sphere ($g = 0$), two for the torus ($g = 1$) (ratio of the radii of the torus and its twist) and $6g - 6$ for $g > 1$. Denoting the moduli as m_i and fixing a reference metric $\hat{g}(m_i)$ in each class, any metric can be written as

$$g_{\alpha\beta} = \hat{g}_{\alpha\beta}(m_i) e^{\phi} \circ \text{Diffeomorphism } \xi. \quad (2.5)$$

3. The decomposition (2.5) is not unique. At genus 0 and 1 there are globally well-defined diffeomorphisms that are equivalent to Weyl rescalings. They form a two-dimensional group for genus 1 (translations) and the six-dimensional group $SL(2, C)$ for genus 0 (translations, rotation, global scale transformation and two special conformal transformations).

The sum over geometries can now be rewritten as

$$\int \mathcal{D}g \rightarrow \sum_{g=0}^{\infty} \int \prod_{i=1}^{6g-6} dm_i \int \mathcal{D}\phi \int \mathcal{D}\xi \times \text{Jacobian}. \quad (2.6)$$

A Jacobian arises because of the change of variables from $g_{\alpha\beta}$ to ϕ, ξ .^[3] It will be discussed next. In (2.6), it is implied that we do not sum over the $SL(2, C)$ -modes of ϕ mentioned above. Otherwise, (2.6) would be infinite. The integral over diffeomorphisms ξ now cancels the volume of the diffeomorphism group in (2.1), provided that there is no gravitational anomaly, which means that the matter sector must not include self-dual spin-2 fields.^[8]

2.3. The Jacobian

When we make a linear change of variables $y^i \rightarrow y'^i = A_j^i y^j$ in finite-dimensional integrals, we pick up a Jacobian $\det A$:

$$\int \prod dy'^i \sim \int \prod dy^i \det A.$$

A also appears in the norm in y space:

$$\|\delta\vec{y}\|^2 = \sum_i (A_i^j \delta y_j)^2.$$

Let us apply this to infinite-dimensional integrals. To find the Jacobian in (2.6), consider the natural (covariant) definition of the measure, i.e., of the norm in the space of metrics:^[3]

$$\begin{aligned} \|\delta g\|^2 &\equiv \int d^2\sigma \sqrt{g} g^{\alpha\beta} g^{\gamma\delta} \delta g_{\alpha\gamma} \delta g_{\beta\delta} \\ &= \int d^2\sigma \sqrt{\hat{g}} e^\phi [(\delta\phi + \hat{\nabla}^\gamma \xi_\gamma)^2 + (L\xi)_{\alpha\gamma} (L\xi)^{\alpha\gamma}], \end{aligned} \tag{2.7}$$

where infinitesimal deformations of the metric have been decomposed as

$$\delta g_{\sigma\rho} = g_{\sigma\rho} \delta\phi + \nabla_\sigma \xi_\rho + \nabla_\rho \xi_\sigma.$$

The operator L in (2.7) and its adjoint L^\dagger are given by

$$\begin{aligned} (L\xi)_{\alpha\beta} &\equiv \hat{\nabla}_\alpha \xi_\beta + \hat{\nabla}_\beta \xi_\alpha - \hat{g}_{\alpha\beta} \hat{\nabla}^\gamma \xi_\gamma, \\ (L^\dagger h)_\gamma &= \hat{\nabla}^\alpha h_{\alpha\gamma}. \end{aligned}$$

L^\dagger acts on a traceless, symmetric tensor. $\hat{\nabla}_\alpha$ is the covariant derivative with respect to \hat{g} . From the above, the Jacobian in (2.6) is seen to be

$$\det L \equiv (\det L^\dagger L)^{\frac{1}{2}}.$$

This determinant is often represented with the help of anticommuting ‘‘Faddeev-Popov ghost fields’’^[7] $c^\alpha, b_{\alpha\beta}$ by the fermionic functional integral

$$(\det L^\dagger L)^{\frac{1}{2}} = \int \mathcal{D}b \mathcal{D}c \exp \left\{ - \int d^2\sigma \sqrt{g} g^{\alpha\gamma} c^\beta \nabla_\alpha b_{\beta\gamma} \right\}. \quad (2.8)$$

Here, $b_{\alpha\beta}$ is a traceless, symmetric tensor of conformal dimension 2, and c_β is a vector of dimension -1 . We can now write (2.1) as

$$\sum_{g=0}^{\infty} \lambda^{(2g-2)} \int \prod_{i=1}^{6g-6} dm_i \int \mathcal{D}\phi (\det L^\dagger L)_{\hat{g}e^\phi}^{\frac{1}{2}} (\det \Delta)_{\hat{g}e^\phi}^{-\frac{D}{2}} \exp \left\{ -\mu \int \sqrt{\hat{g}} e^\phi \right\}. \quad (2.9)$$

The partition function for x has been written as the determinant of the laplacian. The subscripts $\hat{g}e^\phi$ indicate that the determinants are to be evaluated in the curved background $\hat{g}e^\phi(m_i)$. In the above, we have not discussed variations of the moduli m_i . Since in general it is not known how to integrate over the moduli spaces and sum over topologies in the continuum theory, let us focus on the ϕ -integral in the following.

3. The Trace Anomaly and DDK

3.1. The Conformal Anomaly

The next step is to decouple ϕ from the determinants in (2.9). Classically, the free scalars x^i in (2.1) and the ghosts in (2.8) are not coupled to the metric $\hat{g}e^\phi$ at all: their actions are diffeomorphism invariant (of course) and conformally invariant, because the corresponding stress tensors are traceless:^[7]

$$\begin{aligned} T_{\alpha\beta}^{(x)} &= \partial_\alpha x \partial_\beta x - \frac{1}{2} g_{\alpha\beta} \partial^\gamma x \partial_\gamma x \\ T_{\alpha\beta}^{(b,c)} &= \frac{1}{2} c^\gamma \nabla_\alpha b_{\beta\gamma} + \frac{1}{2} c^\gamma \nabla_\beta b_{\alpha\gamma} + (\nabla_\alpha c^\gamma) b_{\beta\gamma} + (\nabla_\beta c^\gamma) b_{\alpha\gamma} \\ &\quad - \frac{1}{2} g_{\alpha\beta} (c^\gamma \nabla^\beta b_{\beta\gamma} + 2(\nabla^\beta c^\gamma) b_{\beta\gamma}). \end{aligned}$$

Quantum mechanically however, the background metric enters the determinants through one-loop graphs like

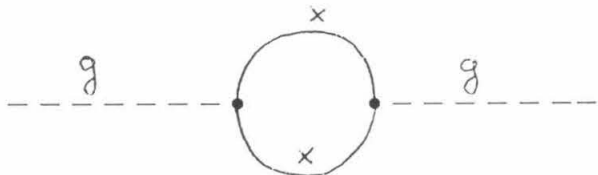
(3.1)

As mentioned, there is no diffeomorphism anomaly, so the determinants are diffeomorphism invariant. But Weyl invariance is spoiled by the conformal anomaly: generally,

$$\det X_{\hat{g}e^\phi} = \det X_{\hat{g}} \times \exp\{-S_{\text{eff}}(\hat{g}, \phi)\} \quad (3.2)$$

where X represents some conformally invariant operator. S_{eff} can be obtained by first computing (3.1) in weak gravitational backgrounds, then using general covariance to determine from this the effective action and then writing it in conformal gauge.^[2] But it is more straightforward to integrate the trace anomaly $\langle T_\alpha^\alpha \rangle$ of the stress tensors of the fields x, b and c , since

$$\delta S_{\text{eff}} = - \int d^2\sigma \sqrt{g} \langle T_{\alpha\beta}(\sigma) \rangle \delta g^{\alpha\beta}(\sigma),$$

hence

$$\frac{\delta S_{\text{eff}}[\hat{g}, \phi]}{\delta \phi} = -\sqrt{g} \langle T_\alpha^\alpha \rangle. \quad (3.3)$$

In any dimension, $\langle T_\alpha^\alpha \rangle$ can be found using the Schwinger-de Witt method by expanding the Green's function of X in a curved background.^[9] In two dimensions, things are much easier: first we regularize the determinants by introducing a short distance cutoff a , for example by putting the theories on a lattice. Since X is conformally invariant, T_α^α is zero and $\langle T_\alpha^\alpha \rangle$ comes only from short distance quantum effects and is therefore local. It must also be generally covariant, and is thus a polynomial

in the curvature. Dimension counting then determines $\langle T_\alpha^\alpha \rangle$ up to a parameter c , the “central charge”:

$$\langle T_\alpha^\alpha \rangle = 1 \times O\left(\frac{1}{a^2}\right) + \frac{c}{48\pi}R + O(a^2). \quad (3.4)$$

c can be read off from the most singular term in the operator product expansion of the stress tensor with itself:^[10,11]

$$T(r)T(0) \sim \frac{c/2}{|r|^4} + \dots \quad (3.5)$$

Well-known results are $c = 1$ for each free scalar field, $c = \frac{1}{2}$ for each free fermion and $c = -26$ for the ghosts b, c . The leading term in (3.4) is infinite, but this will only renormalize the cosmological constant, as will be seen.

3.2. The Liouville Action

We can now integrate (3.3), using (3.4–5). For $d = 2$, the curvature is $\sqrt{g}R = \sqrt{\hat{g}}(\hat{R} - \hat{\square}\phi)$. This yields the effective action^[3]

$$\begin{aligned} S_{\text{eff}}(\hat{g}, \phi) &\equiv S_L = \frac{c}{48\pi}S_0[\hat{g}, \phi] + \int d^2\sigma \sqrt{\hat{g}}\mu' e^\phi \\ S_0 &\equiv \int d^2\sigma \sqrt{\hat{g}}\left(\frac{1}{2}\hat{g}^{\alpha\beta}\hat{\partial}_\alpha\phi\hat{\partial}_\beta\phi + \hat{R}\phi\right) \end{aligned} \quad (3.6)$$

with induced cosmological constant μ' . S_L is called the Liouville action. We see that the conformal anomaly induces a kinetic term for the conformal factor, even though the metric did not seem to be a dynamical variable in (2.1). This is in contrast with the random walk, where $\langle T_\alpha^\alpha \rangle \sim 1 \times O\left(\frac{1}{a}\right) + O(a)$ by dimension counting, thus resulting only in a renormalization of the cosmological constant. In four-dimensional gravity, $\langle T_\alpha^\alpha \rangle$ and S_{eff} will also include generally covariant fourth-order derivative terms,^[9] leading to a unitarity problem in Minkowski space (but not in Euclidean space). See part III for further discussion.

Defining c_m as the combined conformal anomaly of the matter (i.e., if we include matter other than the scalar fields x), the ϕ -integral in (2.9) becomes

$$(\det L^\dagger L)_{\hat{g}}^{\frac{1}{2}} (\det \Delta)_{\hat{g}}^{-\frac{D}{2}} \int \mathcal{D}\phi \exp\left\{\frac{26 - c_m}{48\pi} S_0[\hat{g}, \phi] - (\mu + \mu') \int \sqrt{\hat{g}} e^\phi\right\}. \quad (3.7)$$

3.3. The Measure for ϕ

(3.7) is not yet a field theory as usual, because of the geometric meaning of ϕ as conformal factor. This shows up in the definition of the measure: the generally covariant definitions of the norm in the space of metrics and of the cutoff are (see (2.7); the term $\vec{\nabla} \cdot \vec{\xi}$ has been absorbed in a shift of ϕ):

$$\|\delta\phi\|^2 = \int d^2\sigma \sqrt{\hat{g}} e^\phi (\delta\phi)^2, \quad e^\phi (\delta\sigma)^2 \geq a^2. \quad (3.8)$$

If ϕ were just another field, we would have

$$\|\delta\phi\|^2 = \int d^2\sigma \sqrt{\hat{g}} (\delta\phi)^2, \quad (\delta\sigma)^2 \geq a^2. \quad (3.9)$$

The cutoff a can be introduced, e.g., by regularizing the sum over surfaces as a sum over random triangulations with triangle side length a (see appendix). We see that ϕ lives on a half-line:^[6] for fixed $\delta\sigma$, ϕ must be bounded from below to have $e^\phi (\delta\sigma)^2 \geq a^2$. The bound is set by the smallest possible $\delta\sigma$ (that is, $\delta\sigma_{min}$ between two neighboring lattice sites):

$$\phi \geq \phi_0, \quad e^{\phi_0} (\delta\sigma_{min})^2 = a^2. \quad (3.10)$$

Unlike the measures discussed in subsection 2.3, the measures defined by (3.8) and (3.9) do not correspond to a linear change of variables that can be absorbed in a simple Jacobian. One way to circumvent the problem of the unusual measure for ϕ is to write (3.7) in light-cone gauge rather than conformal gauge, following Knizhnik, Polyakov and Zamolodchikov.^[12] An $SL(2, R)$ symmetry of the model can then be used to solve it with methods of conformal field theory.

3.4. DDK

It is more convenient, though, to proceed in conformal gauge following David,^[4] Distler and Kawai^[5] (DDK): Their idea was to replace ϕ with an ordinary field, also called ϕ , whose measure $D_{\hat{g}}\phi$ is defined by (3.9). Their conjecture, later confirmed in [46], was that this change in the measure can be absorbed by replacing the action (3.6) for ϕ with the most general local renormalizable action. This is the Liouville action itself, but with modified coefficients Q, α, μ :

$$S[\hat{g}, \phi] = \frac{1}{8\pi} \int d^2\sigma \sqrt{\hat{g}} \{ \hat{g}^{\alpha\beta} \partial_\alpha \phi \partial_\beta \phi + Q \hat{R}\phi + \mu e^{\alpha\phi} \}. \quad (3.11)$$

Here ϕ has been normalized so that the kinetic term is standard. Quantum gravity is now described by three ordinary field theories, for $b + c$, x , and ϕ . For this to be consistent, the combined theory must be scale invariant: scale invariance was part of the general covariance of the original theory. An arbitrary gauge choice corresponding to the background metric \hat{g} has been made in (2.5) to parametrize metrics in conformal gauge. Now that ϕ is just a dummy integration variable, everything should be invariant under rescaling of \hat{g} .

Scale invariance turns out to specify the action for ϕ completely. For $\mu = 0$, it means that the total conformal anomaly must vanish:^{*}

$$c_\phi + c_m - 26 = 0 \quad \rightarrow \quad 3Q^2 = 25 - c_m,$$

because (3.11) has $c_\phi = 1 + 3Q^2$. This is derived as follows. Even for $\mu = 0$, (3.11) is not quite conformally invariant because of the term $Q\hat{R}\phi$. Locally, we can write

$$\hat{g}_{\alpha\beta} = \delta_{\alpha\beta} e^{\hat{\phi}}, \quad \text{so} \quad \sqrt{\hat{g}} \hat{R} = -\square \hat{\phi}.$$

^{*} This can also be seen directly by studying the original theory in (3.7), by simultaneously shifting $\hat{g} \rightarrow \hat{g}e^\sigma$, $\phi \rightarrow \phi - \sigma$: The ϕ theory behaves exactly like a conformal field theory with central charge $c_\phi = 26 - c_m$.

Then,

$$\begin{aligned} S_0(\hat{g}, \phi) &\sim \int d^2\sigma \sqrt{\hat{g}} \{ \hat{g}^{\alpha\beta} \partial_\alpha \phi \partial_\beta \phi + Q \hat{R} \phi \} \\ &= - \int d^2\sigma \{ \phi \square \phi + Q \hat{\phi} \square \phi \} = - \int d^2\sigma \left(\phi + \frac{Q}{2} \hat{\phi} \right) \square \left(\phi + \frac{Q}{2} \hat{\phi} \right) - \frac{Q^2}{4} S_0(\delta, \hat{\phi}). \end{aligned}$$

Up to a shift of ϕ , the first term on the RHS describes an ordinary scalar field with $c = 1$. The second term is just the Liouville action for $\hat{g} = \delta$. Comparing with (3.6), we see that this term gives a ‘‘classical contribution’’ $3Q^2$ to the central charge.

It follows from the above that

$$Q = \sqrt{\frac{25 - c_m}{3}}. \quad (3.12)$$

When μ is turned on in (3.11), scale invariance implies that the cosmological constant $e^{\alpha\phi}$ must be a marginal operator, i.e., of conformal dimension two (to cancel the two from $\sqrt{\hat{g}}$). To exploit this piece of information, we first shift ϕ by $(Q/2)\hat{\phi}$, as above. Then the condition on the dimension becomes

$$\dim(e^{\alpha\phi}) = 2 + Q\alpha \quad \text{with action} \quad \frac{1}{8\pi} \int d^2\sigma (\partial\phi)^2.$$

With this action, the propagator $\langle \phi(r)\phi(0) \rangle$ is $-\log(r^2)$.[†] The easiest way to compute the (classical plus anomalous) dimension of the operator $e^{\alpha\phi}$, which is assumed to be normal ordered, is to consider the two-point function

$$\langle e^{\alpha\phi(r)} e^{-\alpha\phi(0)} \rangle = e^{-\alpha^2 \langle \phi(r)\phi(0) \rangle} = (r^2)^{\alpha^2},$$

yielding the dimension $-\alpha^2$.

[†] It is sufficient to use the free field action to compute the dimension.^[14] An infrared cutoff, which is required, is not shown.

So without shifting ϕ ,

$$\dim(e^{\alpha\phi}) = -\alpha(\alpha + Q), \quad (3.13)$$

$$\rightarrow \alpha = \frac{1}{2\sqrt{3}}(\sqrt{25 - c_m} + \sqrt{1 - c_m}). \quad (3.14)$$

For α (and therefore the action) to be real, we need $c_m \leq 1$. That is, the “matter” must be a “minimal model”[‡] or a single coordinate x . It is believed that the surfaces are in a branched polymer phase for $c_m > 1$. More about this $c = 1$ barrier will be said in the next section.

When $c_m = 25$, the $\hat{R}\phi$ -term in (3.11) vanishes and ϕ is an ordinary scalar field. From (3.14), α is imaginary in this case; it can be made real by redefining $\phi \rightarrow i\phi$. Then ϕ becomes timelike and (3.11) is the usual world sheet action of the critical bosonic string, obtained by coupling 25 space coordinates x^i and one time coordinate ϕ to 2D gravity and ignoring the conformal anomaly.

3.5. Gravitational Dressing

So far, the x^μ have been free fields in (2.1), but we can also add interactions in the form of scaling operators $\Phi_i(x)$ with positive scaling dimensions, $h_i \geq 0$, and small coupling constants t^i . Scaling operators are operators of definite scaling dimensions. Their two-point functions are just powers of their distance. Examples in two dimensions are the normal ordered operator $\cos px$, or the operator $e^{\alpha\phi}$ of the last subsection.

Before coupling to gravity, the perturbed matter action is

$$S = \int d^2\sigma \sqrt{g} \{(\partial x)^2 + t^i \Phi_i(x)\}. \quad (3.15)$$

Here, summation on i is understood. After coupling to gravity and replacing the measure for ϕ by (3.9), the interaction terms $\Phi_i(x)$ will get “gravitationally dressed,”

[‡] E.g., the Ising model with $c = 1/2$

that is, they will become mixed operators $\hat{V}_i(x, \phi)$. So we make the ansatz

$$S = \int d^2\sigma \sqrt{g} \{ (\partial x)^2 + (\partial \phi)^2 + Q \hat{R} \phi + t^i \hat{V}_i(x, \phi) + \text{cosmol. const.} \}. \quad (3.16)$$

Then scale invariance again determines the \hat{V}_i . It implies that the t^i do not “run,” that is, their beta functions must be zero. The beta functions are ^[13]

$$0 = \beta^i = (\Delta_j^i - 2\delta_j^i) t^j + \pi c_{jk}^i t^j t^k + \dots \quad (3.17)$$

Here, Δ_j^i is the dimension matrix of the operators \hat{V}_i , defined by

$$(L_0 + \bar{L}_0) \hat{V}_j = \Delta_j^i \hat{V}_i,$$

where $(L_0 + \bar{L}_0)$ is the generator of scale transformations. The c_{jk}^i are the operator product coefficients in the short-distance expansion

$$\hat{V}_j(\vec{r}) \hat{V}_k(\vec{0}) \sim (\vec{r}^2)^{-1} \sum_i c_{jk}^i \hat{V}_i(\vec{0}).$$

To lowest order in t , Δ_j^i must be $2\delta_j^i$. From (3.14), this is obeyed by

$$\hat{V}_i = \Phi_i(x) e^{\gamma_i \phi} \quad \text{with} \quad \gamma_i = \frac{1}{2\sqrt{3}} (\sqrt{25 - c_m} - \sqrt{1 - c_m + 24h_i}). \quad (3.18)$$

In particular, the cosmological constant is the ‘dressed’ unit operator 1. If c_m is such that α in (3.14) is real, all the γ_i will be real, since the operators Φ_i have dimensions $h_i \geq 0$. Therefore, the \hat{V}_i will not lower the $c = 1$ barrier.

While background invariance was imposed to first order in t by DDK, leading to (3.18), the implications of (3.17) at $O(t^2)$ have not previously been studied. This will be done in part II. We will see that this requires new terms of $O(t^2)$ in (3.16).

4. Applied Liouville Theory

Here we use the formalism developed above to discuss briefly some critical exponents (in subsection 4.1) and the spectrum of the theory (in subsection 4.2) with its geometric interpretation (in subsection 4.3). We are restricted to the case $c_m \leq 1$, where (3.11) is well-defined. The case $c = 1$ will be used as an example in subsection 4.4. More aspects of Liouville theory and its gravitational interpretation are discussed in the appendices of Part II.

4.1. Correlation Functions and Critical Exponents

Unfortunately, there is not yet a satisfactory way to compute correlation functions

$$\langle \prod_i \Phi_i(x) e^{\gamma_i \phi} \rangle$$

in Liouville theory. The main obstacle is the exponential potential $e^{\alpha\phi}$. In particular, ϕ -momentum is not conserved, as it would be in free field theory. The potential cannot be treated perturbatively in μ , starting from the free theory with $\mu = 0$, because the cosmological constant diverges in the infrared ($\alpha\phi \rightarrow \infty$). Thus, it cannot be made small – rescaling μ just shifts it in ϕ -space. So it must be included in the path integral from the start and dealt with nonperturbatively. It is not yet clear how to do this integral in general (see however [15,16]).

The area-dependence of the correlators can be extracted quite easily, though, and from this some critical coefficients can be deduced. To this end, consider the sum over surfaces of given area A . The fixed-area partition function is defined as

$$Z(A) \equiv \langle \delta\left(\int d^2\sigma \sqrt{\hat{g}} e^{\alpha\phi} - A\right) \rangle = e^{-\mu A} Z_0(A), \quad (4.1)$$

where Z_0 is the partition function with action S_0 , the free part of (3.11). $Z_0(A)$ can be found up to a proportionality factor by shifting ϕ by a constant:^[4,5]

$$\begin{aligned}
\phi \rightarrow \phi + c &\Rightarrow S_0 \rightarrow S_0 + 4\pi\chi c \\
&\Rightarrow Z_0(A e^{\alpha c}) = Z_0(A) e^{c(Q(1-g)-\alpha)} \\
&\Rightarrow Z_0(A) \propto A^{Q(1-g)/\alpha-1} \\
&\Rightarrow Z(A) \propto e^{-\mu A} A^{\gamma-3},
\end{aligned} \tag{4.2}$$

$$\text{with } \gamma = 2 + (1-g)\frac{Q}{\alpha} = 2 + \frac{1-g}{12}(d-25 - \sqrt{(25-d)(1-d)}). \tag{4.3}$$

The coefficient γ is called the string susceptibility, and this formula for γ agrees with the matrix model results.^[17]

Similarly, one finds for the fixed-area correlation functions of the operators (3.18), up to a proportionality factor:

$$\begin{aligned}
\langle \hat{V}_1 \dots \hat{V}_n \rangle_A &\equiv \langle \hat{V}_1 \dots \hat{V}_n \delta(\int d^2\sigma \sqrt{\hat{g}} e^{\alpha\phi} - A) \rangle \\
&\propto e^{-\mu A} A^{\gamma-3+\sum \gamma_i/\alpha}.
\end{aligned}$$

This can be integrated over A from some cutoff ϵ to ∞ , assuming $(2g-2) + \sum \gamma_i > 0$ so that the integral converges. Due to the cutoff on ϕ , i.e., on A , cutoff-dependent terms will be added otherwise.^[18] The result for the μ -dependence of the correlators is

$$\begin{aligned}
\langle \hat{V}_1 \dots \hat{V}_n \rangle_\mu &\equiv \int_\epsilon^\infty dA e^{-\mu A} \langle \hat{V}_1 \dots \hat{V}_n \rangle_A \\
&\propto \mu^{-(\gamma-2+\sum \gamma_i/\alpha)}.
\end{aligned} \tag{4.4}$$

This also agrees with the matrix model results.^[17] The power of μ is in general fractional. This confirms that we must treat the cosmological constant nonperturbatively, because perturbation theory in μ could have produced integer powers of μ only.

Another interesting coefficient is the Hausdorff dimension d_H of random surfaces:

$$\langle x^2 \rangle_A \propto e^{-\mu A} A^{2/d_H}.$$

This measures the mean extension $\langle x^2 \rangle$ of the surface in target space versus the intrinsic area A . The random walk is well-known to have $d_H = 2$, independently of the dimension of the embedding space. For random surfaces, one can show with the above methods that:^[19]

$$d_H = \frac{24}{1 - D + \sqrt{(25 - D)(1 - D)}}. \quad (4.5)$$

This, too, agrees with the matrix model results. Note that d_H depends on the embedding dimension. For $D = 1$, $d_H = \infty$, i.e., $\langle x^2 \rangle \propto \log A$.

The Hausdorff dimension is useful to investigate the relevance of interactions in the first-quantized formulation. E.g., ϕ^4 theory can be viewed as a second-quantized self-interacting random walk. It becomes free in the renormalization group sense in $D > 2d_H = 4$ embedding dimensions, because then two paths typically do not intersect and the interaction term is thus irrelevant. Unfortunately, the analogous statement for string theory can presently only be made for $D \leq 1$, where $2d_H > D$. The statement is that interactions of the $D \leq 1$ string are “relevant.”

4.2. States and Operators

For further applications, it is important to know the eigenstates of the Hamiltonian (if we think of one of the coordinates as time), or equivalently, to know the operators that create these states when acting on the vacuum. Those are the scaling operators (i.e., the operators of definite scaling dimension, like $e^{\alpha\phi}$) that can be constructed in the theory. The reason is that, up to a constant, the Hamiltonian can be identified with the generator of scale transformations:

Consider inserting an operator at a point P of the surface Σ on which our theory lives (fig.3a). Deform the surface into a cylinder by a conformal transformation that maps P to infinity, as shown in fig. 3b. Translations along the axis of the cylinder, generated by the Hamiltonian \mathcal{H} , correspond to scale transformations on Σ , whose generator we call $L_0 + \bar{L}_0$ as before. When the action of the fields that live on Σ is conformally invariant, \mathcal{H} and $L_0 + \bar{L}_0$ would be the same if it were not for the conformal anomaly. Due to the latter, \mathcal{H} and $L_0 + \bar{L}_0$ actually differ, but only by a constant, which is proportional to the central charge c (see e.g., ref. [13]).

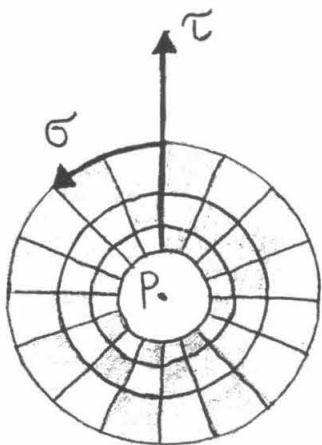

Fig. 3a: A surface with an operator inserted at P

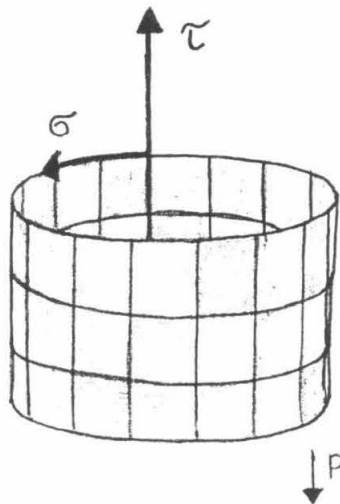

Fig. 3b: The same surface, deformed to a cylinder

As explained above, if we think of Liouville theory as quantum gravity, we should combine operators of the x and the ϕ sectors to obtain scaling operators of dimension two,^{*} as in (3.18). This will be done for the example of the $c = 1$ model in subsection (4.4). We should also interpret ϕ as the conformal factor. This will be done in subsection (4.3). Here, let us forget about gravity and just study the spectrum of Liouville theory as a theory of its own.

* More precisely, we should impose the Virasoro constraints.

What are the scaling operators in the theory? Ignoring for now the cosmological constant,[†] and considering only operators without derivatives, they are the exponentials

$$\exp\{\epsilon\phi\} \quad \text{with dimension} \quad d_\epsilon = -\epsilon(\epsilon + Q) = -\left(\epsilon + \frac{Q}{2}\right)^2 + \frac{Q^2}{8}, \quad (4.6)$$

as discussed above. For the dimension to be real, $\beta \equiv \epsilon + Q/2$ must be real or imaginary. For real β , the dimensions are not bounded from below. Thus the Hamiltonian of the ϕ sector is not bounded from below, but this will be taken care of by the x part of the operators (3.18). For imaginary β , the hermitean combinations of the operators are actually

$$\exp\left\{-\frac{Q}{2}\phi\right\} \sin(\beta\phi + \Theta). \quad (4.7)$$

Next, what are the eigenstates of the Hamiltonian? To answer this, deform a Riemann surface with boundary to a half-open cylinder, insert all the background curvature (and possible handles) and an operator O_i in the far past as shown below (fig. 4a), and consider the wave function $\psi_i(\phi)$ on the boundary. Let us only consider the quantum mechanics problem of the constant mode $\phi_c(\sigma, \tau) = \phi_c(\tau)$ (σ is here the coordinate along the circle, and τ is “time”). From the corresponding minisuperspace action

$$S(\phi_c, \dot{\phi}_c) \sim \frac{1}{8\pi} \int d\tau (\dot{\phi}_c^2 + \mu e^{\gamma\phi_c})$$

one derives the Schrödinger equation

$$\left(-\frac{1}{2} \frac{\partial^2}{\partial \phi_c^2} + \mu e^{\gamma\phi_c}\right) \psi(\phi_c) = E \psi(\phi_c). \quad (4.8)$$

The potential and the solutions^[18] are shown in fig. 4b.

[†] With cosmological constant, these operators will get modified at large negative ϕ .^[6]

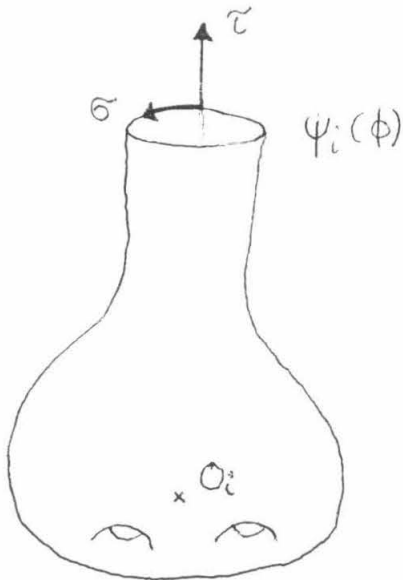

Fig. 4a: Riemann surface with boundary, two handles and an operator insertion

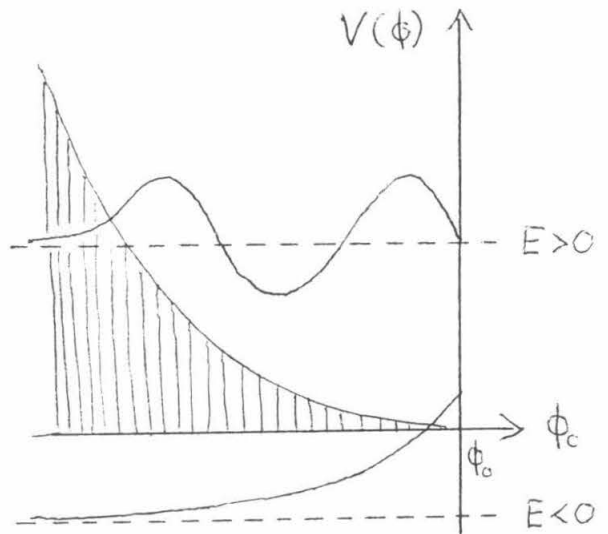

Fig. 4b: Two types of wave functions of states with $E > 0$ and $E < 0$

For $E > 0$, there are oscillating states, behaving like $\sin(\beta\phi_c + \Theta)$ for $\phi_c \rightarrow \infty$. If the range of ϕ_c was $[-\infty, \infty]$, there would be no ground state: for $E = 0$, the wave function diverges linearly for $\phi_c \rightarrow \infty$ and would thus not be normalizable. But since there is an upper bound ϕ_0 on ϕ_c , the state exists and its wave function is peaked at $\phi_c = \phi_0$. Likewise, all other states whose wave functions diverge as $\phi_c \rightarrow \infty$ should be included in the spectrum.^[18] On the other hand, states that diverge at $\phi_c \rightarrow -\infty$ do not exist.

Third, how do the states correspond to the operators? Because of the background charge, the vacuum wave function behaves like $e^{-(Q/2)\phi_c}$ and the operator $e^{\epsilon\phi}$ in (4.6), when acting on the vacuum, creates the state with $\psi(\phi_c) \propto e^{(\epsilon-Q/2)\phi_c}$ as $\phi_c \rightarrow -\infty$. Since no states exist for $\epsilon < \frac{Q}{2}$, one concludes that the operators (4.6) also exist only for $\epsilon \geq \frac{Q}{2}$.^[18,20] More precisely, one can argue that the operators with $\epsilon < \frac{Q}{2}$ cannot be renormalized (see ref. [20]). Finally, the oscillating states obviously correspond to the operators (4.7).

4.3. Geometric Interpretation

Interpreting ϕ as conformal factor means interpreting

$$A = \int_{\Sigma} d^2\sigma e^{\alpha\phi} \quad \text{and} \quad l = \oint_{\partial\Sigma} d\sigma e^{\frac{\alpha}{2}\phi}$$

as the area of the surface Σ and the length of its boundary $\partial\Sigma$. From the previous discussion, the expectation value $\langle l \rangle$ is of the order of the cutoff ($e^{(\alpha/2)\phi_0}$) for the exponentially growing states.* They are thus called “microscopic.”^[17] $\langle l \rangle$ is finite for the operators (4.10) and their states, which are thus called “macroscopic.” Although these operators are local in the background metric, they are not local in the physical metric. Inserting them into the surface cuts a macroscopic hole into it: a closed line drawn around the insertion, no matter how closely, will always have some finite circumference $\langle l \rangle$.

This gives a geometric interpretation to the $c = 1$ – barrier of 2D gravity. Consider the cosmological constant operator $e^{\alpha\phi}$ with α given by (3.14). For $c > 1$, α acquires an imaginary part and the cosmological constant becomes a macroscopic operator like (4.7). While inserting it into the surface cuts a hole, adding it to the action, i.e., inserting its exponential, destroys the surface.^[18] We thus expect a phase transition at $c = 1$.

In the language of string theory, the barrier is related to the presence of target-space tachyons for embedding dimension $c > 1$. The condition that the vertex operator $: e^{i\vec{p}\vec{x} + \epsilon\phi} :$ be of dimension two yields the mass m of the lowest string state:

$$\vec{p}^2 - \left(\epsilon + \frac{Q}{2}\right)^2 = \frac{Q^2}{4} - 2 \equiv m^2. \quad (4.9)$$

m^2 is negative for $Q^2 < 8$, i.e., $c > 1$. In this case there are plane waves with imaginary ϵ (macroscopic operators) and negative m^2 (tachyons), one of them ($\vec{p} = 0$) being the cosmological constant. On the other hand, for unitary theories with $c \leq 1$ ($Q^2 \geq 8$), all physical states are microscopic^[18] (real ϵ) and there are no tachyons.

* We see this from the minisuperspace approximation of the last subsection. From the matrix model results it is known that this approximation is exact.

4.4. 2D String Theory at $c = 1$

The most physical case that can be discussed in the present framework is that of gravity coupled to an (uncompactified) scalar field x with $c = 1$. This is the theory of random surfaces embedded in one dimension. From (3.12), $Q = 2\sqrt{2}$. (4.3) and (4.5) yield the critical coefficients $\gamma = 0$ on genus zero and $d_H = \infty$. The action is

$$\frac{1}{8\pi} \int d^2\sigma \sqrt{\hat{g}} \{ \partial_\alpha x \partial^\alpha x + \partial_\alpha \phi \partial^\alpha \phi + 2\sqrt{2} \hat{R}^{(2)} \phi + \mu e^{\gamma\phi} + \text{ghosts } b, c \}. \quad (4.10)$$

Examples of matter scaling operators are e^{ikx} , $\sin kx$, $\cos kx$ with dimensions $h_k = k^2$. From (3.18), the dressed operators are

$$\hat{V}(k) \equiv e^{ikx + \epsilon\phi} \quad \text{with} \quad \epsilon = -\sqrt{2} \pm k. \quad (4.11)$$

What makes the $c = 1$ model particularly interesting is the fact that (4.10) can be viewed as the world-sheet action of a critical string theory in *two* target space dimensions x and ϕ .^[6] The dilaton background $\Phi(x, \phi) = Q\phi$ in (4.10) is responsible for lowering the critical dimension from 26 to 2. This is further discussed in part II, appendix A.

From the analysis of the $c = 1$ matrix model, the correlation functions of (4.10) are known to all orders in the string loop expansion, i.e., summed over all genera, and beyond. This makes 2D string theory an interesting toy model for more realistic (26D) string theories. One might think that it is a rather boring toy model, because there are no transverse directions in which the string can oscillate. Thus the spectrum can contain no target-space gravitons or higher excited modes, only the ‘‘tachyons’’ corresponding to the operators (4.11). This is not quite so: the spectrum contains discrete remnants of the graviton and the higher string modes at special momenta^[24,25] (see part II, section 2.3). For a review of the $c = 1$ model, see ref. [26].

Appendix: Random Lattices and Matrix Models

In the above we have often referred to numerical results obtained from the “matrix models.” For completeness, the basic idea of this approach is explained below. For a complete review, see e.g., [17,26].

A.1. Random Triangulations

The path integral over unembedded ($D = 0$) two-dimensional Euclidean geometries can be regularized in a diffeomorphism invariant way as a sum over triangulations of a surface (figure 5a). The side length a of the triangles is held fixed while the number of triangles joining at each vertex is allowed to vary. The sum runs over all distinct graphs, i.e., all graphs that cannot be mapped onto each other.

Let us define F , E and V as the numbers of faces (triangles), edges and vertices of a graph like the one in figure 3. $V - E + F$ is well known to be the Euler characteristic $\chi = 2 - 2g$ of the manifold, g being its genus. The area is $\sim a^2 \times F$. The discretized partition function (2.1) (without x) is thus

$$W(\lambda_0, \mu_0) = \sum_{\text{graphs}} \lambda_0^{-(V-E+F)} \exp\{-\mu_0 F\}, \quad (\text{A.1})$$

with bare “string coupling constant” $\lambda_0 = e^{4\pi\gamma}$ and bare cosmological constant μ_0 .

Let us first restrict ourselves to genus zero: $V - E + F = 2$. The sum over genera will be discussed in subsection A.3. It is known (and suggested by (4.2)) that the number of distinct triangulations with a fixed number of triangles grows to leading order like $e^{\mu_c F} F^{\gamma-3}$ as $F \rightarrow \infty$, with some coefficients μ_c, γ . By fine-tuning $\mu_0 \sim \mu_c$ and simultaneously letting a go to zero, the continuum limit is reached where the sum (A.1) just starts to diverge.* Intuitively one expects that, in this limit and for genus zero, (A.1) becomes the partition function of two-dimensional quantum gravity on

* Actually, for pure gravity $\gamma - 3 = -\frac{7}{2}$, so there is no continuum limit. This can be cured by either inserting operators or adding matter.

on the sphere,

$$Z = \frac{1}{\lambda_0^2} \int \frac{Dg}{\text{Diff}} \exp\left\{-\mu \int d^2\sigma \sqrt{g}\right\} \quad (\text{A.2})$$

with renormalized cosmological constant μ :

$$\mu = \frac{(\mu_0 - \mu_c)}{a^2}. \quad (\text{A.3})$$

To establish the equivalence of (A.1) and (A.2) beyond the intuitive level, one has to show that in the continuum limit the measure for the discretized sum becomes the Polyakov measure (2.7). This has not been proven rigorously, but it can be expected on the grounds that the definition of the sum is diffeomorphism invariant (invariant under permutation of the vertices), and that (2.7) is the only diffeomorphism invariant measure for $g_{\alpha\beta}$ that can be constructed. Further confirmation comes from the agreement of the results of the continuum approach and the matrix model approach.

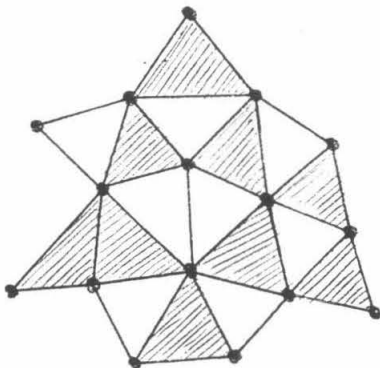

fig. 5a:
A random triangulation

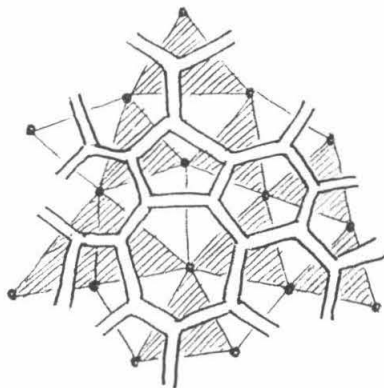

fig 5b:
Its dual

A.2. The Matrix Models

The trick that makes it possible to actually perform the sum (A.1) is by now well-known:^[1] Consider the partition function of a zero-dimensional ϕ^3 theory, where ϕ is a hermitean $N \times N$ matrix:

$$e^{W(\alpha)} = \int d^{N \times N} \phi \exp\{-N \operatorname{tr}(\frac{1}{2}\phi^2 + \alpha\phi^3)\}. \quad (\text{A.4})$$

The normalizations have been chosen for later convenience.

There are two ways to compute $W(\alpha)$: (i), perturbatively by summing the connected Feynman diagrams, or (ii), by just doing the integral.^[27,28] (ii) is much easier and therefore used to actually do the computation. We refer to the literature for this.^[17]

(i), on the other hand, serves to establish that (A.4) is equivalent to (A.1). One only has to note that the connected Feynman graphs of (A.4) and the triangulations of (A.1) are in one-to-one correspondence: they are dual to each other.* The diagrams are gluon-diagrams as in fig. 5b. V is the number of loops, E the number of propagators and F the number of vertices in the Feynman graphs. With propagators $1/N$, each graph in the perturbation expansion of (A.4) is weighted by

$$(\alpha N)^F N^{-E} N^V = \alpha^F N^{V-E+F}, \quad (\text{A.5})$$

where the factor N^V comes from the N different flavors propagating in each loop. With $\alpha = e^{-\mu_0}$ and $\lambda_0 = 1/N$, this yields precisely (A.1). In particular, as $N \rightarrow \infty$, only planar diagrams will survive, corresponding to a sum over triangulations of a genus zero surface. In the continuum limit $\mu_0 \rightarrow \mu_c$, where the gluon-nets become dense, this sum becomes the partition function (A.2) for quantum gravity on a sphere.

* The dual graph of a triangulation is obtained by replacing each face by a vertex and each vertex by a face.

Correlation functions can also be represented in terms of matrix integrals.^[17] Consider (A.4) with insertions of $\text{tr } \phi^n$:

$$\int d^{N \times N} \phi \exp\{-N \text{tr}(\frac{1}{2}\phi^2 + \alpha\phi^3)\} \text{tr } \phi^{n_1} \dots \text{tr } \phi^{n_k}.$$

This corresponds to summing diagrams with external legs. One easily sees that their duals are triangulations with k holes of sizes $n_1 \cdot a, \dots, n_k \cdot a$. In the continuum limit, these holes correspond to insertions of operators – of “microscopic operators,” if n_k is held fixed as $a \rightarrow 0$, and of “macroscopic operators” if $n_k \cdot a$ is held fixed (compare with subsections 4.2, 4.3).

The matrix model (A.4) can be generalized by modifying the potential in the exponential or by introducing more than one matrix. The resulting matrix integrals have been identified as partition functions and correlation functions of gravity coupled to matter with central charge $c \leq 1$. The most interesting solvable matrix model is the one-dimensional one:^[29] The matrix is a one-dimensional field $\phi(t)$, and the partition function is

$$e^W = \int D^{N \times N} \phi(t) \exp\{-N \int dt \text{tr}(\frac{1}{2}\dot{\phi}^2 + \frac{1}{2}m\phi^2 + \alpha\phi^3)\}. \quad (\text{A.6})$$

In the perturbation expansion, each diagram is now weighted by

$$\alpha^F N^{(V-E+F)} \int \prod_k dt_k \prod_{\langle ij \rangle} e^{-m|t_i - t_j|}, \quad (\text{A.7})$$

instead of (A.5). Here, $\langle ij \rangle$ are neighboring vertices in the Feynman diagrams, and $e^{-m|t|}/N$ is the propagator of (A.6). In the continuum limit, obtained by tuning α to its critical value, t turns into a scalar field on a two-dimensional surface. It is believed that in the continuum limit universality allows replacing the propagator by e^{-mt^2}/N . Then the Gaussian nearest-neighbor interaction becomes a standard

kinetic term for t . So the integral in (A.7) becomes

$$\int Dt(\sigma) \exp\{-m \int d^2\sigma (\partial t)^2\}.$$

This establishes that, in the continuum limit, W is the partition function of a free boson with $c = 1$, coupled to gravity.

The beautiful nonperturbative calculation of integral (A.6), by interpreting it as the ground state energy of N free fermions^[27] (the matrix eigenvalues), is not the topic of this review, so we just refer to the extensive literature, e.g., [26].

A.3. Sum over Topologies

Matrix models can also be used to sum over all genera.^[30] Consider again the sum (A.1), but now with surfaces of arbitrary genus, $V - E + F = 2 - 2g$. Then

$$W(\lambda_0, \mu_0) = \sum_{g=0}^{\infty} \lambda_0^{2g-2} W_g(\mu_0). \quad (\text{A.8})$$

From (4.3–4) we know how W_g scales with $\mu \propto (\mu_0 - \mu_c)$ in the continuum limit:

$$\begin{aligned} W_g(\mu_0) &\propto (\mu_0 - \mu_c)^{\gamma_0(1-g)} \\ \Rightarrow W(\lambda_0, \mu_0) = W(\kappa) &= \sum_{g=0}^{\infty} \kappa^{(2g-2)} w_g \quad \text{with} \quad \kappa = \frac{\lambda_0}{(\mu_0 - \mu_c)^{\gamma_0/2}}, \end{aligned} \quad (\text{A.9})$$

with $\gamma_0 = 5/2$ for pure gravity^{*} and some constants w_g . In order to obtain a sensible continuum limit, one must therefore also take $\lambda_0 \rightarrow 0$, as $\mu_0 - \mu_c \rightarrow 0$. Recalling (A.3), one sees that the string coupling constant gets renormalized^{**} to

$$\lambda = \lambda_0 (a^2)^{-\gamma_0/2} \quad \text{so that} \quad \kappa = \lambda \mu^{-\gamma_0/2} = \text{finite.}$$

* More generally, $\gamma_0 = -Q/\alpha$ for gravity with matter

** Note, however, that from (4.3), $\kappa = \lambda_0$ for $c = 25$.

In the matrix model, we had $\lambda_0 = 1/N$ and $\mu_0 = -\log \alpha$. The limit where $N \rightarrow \infty$ and simultaneously $\alpha \rightarrow \alpha_c = e^{-\mu_c}$ so that κ is kept fixed is called the double-scaling limit. The matrix integral (A.4) in this limit is the partition function of quantum gravity with topological expansion parameter κ . Quantum gravity on the sphere is recovered for $\kappa \rightarrow 0$, that is, $N \rightarrow \infty$ for small but fixed $\alpha - \alpha_c$.

Integral (A.4) in the double-scaling limit can be evaluated.^[30] It is found that $\tilde{W}(t)$, defined by $\tilde{W}(t) = W(\kappa)$ with $t = \kappa^{-\gamma_0/2}$, obeys the Painlevé equation

$$t = \tilde{W}^2 - \frac{1}{3}\ddot{\tilde{W}}. \quad (\text{A.10})$$

This result has yet to be obtained from the Liouville approach.

PART II: RUNNING COUPLING CONSTANTS IN 2D GRAVITY[★]

1. Introduction

It was pointed out in subsection 3.5 of part I, that interactions in two-dimensional quantum gravity must be exactly marginal. As will be shown in this part of the thesis, this implies that new terms must be added to the action (3.16). They have not been considered previously, but are important for understanding the renormalization group flow and can be observed in recent matrix model results for the phase diagram of the Sine-Gordon model coupled to gravity.

Let us recall the issue. Two-dimensional quantum gravity coupled to $c \leq 1$ matter ‘ x ’ is described in conformal gauge^[4,5] in terms of fields propagating in a fictitious background metric $\hat{g}_{\alpha\beta}$. The action is the appropriate conformally invariant free action plus interaction terms which are usually assumed to be of the form

$$\mathcal{L}_{int} = \text{cosmological constant} + \sum_i \tau^i \int \Phi_i(x) e^{\alpha_i \phi}, \quad (1.1)$$

where Φ_i are primary fields of the matter theory, the τ^i are small coupling constants, ϕ is the Liouville mode and the α_i are adjusted to make the dimensions of the operators equal to two. However, (1.1) cannot be the complete interaction, for at least two reasons:

1. The operators in (1.1) are not exactly marginal.[†] They should be, because the Liouville theory must be background independent as a consequence of general covariance.^[4,5] Therefore the beta functions of the theory must be zero to all orders in the couplings. Adjusting the α_i in (1.1) makes them zero to first order, but the beta functions have quadratic pieces whenever there are nontrivial OPE's,[‡] as in formula (3.17) of part I.

[★] based on a paper to be published in Nuclear Physics B

[†] An operator is marginal if its dimension is two, and exactly marginal if its beta function is zero to all orders.

[‡] See section 2 for the issue of renormalization schemes and field redefinitions

2. The renormalization group flow would be quite trivial with (1.1). As mentioned, there should be no flow with respect to the fictitious background scale $\sqrt{\hat{g}}$. But, as explained in section 3, a constant shift of ϕ should be interpreted as a rescaling of the physical cutoff,^[6,35,33] and should, in particular, result in a mixing (flow) between different operators. This does not happen in (1.1).

It is shown in section 2 that the first problem can be solved by adding a term

$$\propto -c_{ij}^k \tau^i \tau^j \int \Phi_k(x) \phi e^{\alpha_k \phi} \quad (1.2)$$

to the interaction (1.1), where c_{ij}^k are the operator product coefficients. This, in fact, also resolves the second problem: the modified interaction displays the expected operator mixing under shifts of ϕ by a constant. Requiring that there be *no* flow with respect to the background scale $\sqrt{\hat{g}}$ determines the flow with respect to the physical scale $\sqrt{\hat{g}} e^{\alpha \phi}$. For the case of the Sine–Gordon model coupled to gravity it will be seen that this flow qualitatively agrees with recent matrix model results by Moore.^[31]

Equation (1.2) should be viewed as a second–order correction to the gravitational dressing of the $\Phi_i(x)$. We conjecture that further modifications of (1.1)+(1.2) can be made order by order in the τ^i , leading to an infinite dimensional space of exactly marginal perturbations. Our calculations serve to verify this conjecture to second order. This part of the thesis is organized as follows:

In section 2, the second–order corrections (1.2) are discussed. First, it is shown in subsection 2.1 that the interaction (1.1) plus (1.2) is marginal up to second order. That the correction (1.2) is essentially unique is argued in appendix A by thinking of the marginality conditions as equations of motion of string theory. The $c = 1$ model coupled to gravity is discussed as an example. In subsection 2.2, the interaction term is taken to be the Sine–Gordon interaction near the Kosterlitz–Thouless momentum $p = \sqrt{2}$ and near $p = \frac{1}{2}\sqrt{2}$. In subsection 2.3, the interaction terms are taken to be the “discrete operators.” The effects of including the cosmological constant are studied in appendix B. The conclusions of appendices A and B are summarized in subsection 2.4.

In section 3, running coupling constants are discussed. They are defined in subsection 3.1 so that they absorb a constant shift of ϕ . In subsections 3.2 and 3.3 this is applied to the Sine-Gordon model and the resulting phase boundaries are compared with those found with the nonperturbative matrix model techniques.^[31] It is seen that the presence of the terms (1.2) is crucial even for qualitative agreement of the matrix model and the Liouville theory approaches. A more detailed comparison of both is left for future work. The one-loop beta functions for the discrete $c = 1$ operators are also obtained.

In section 4, possible extensions of this work are pointed out, as well as implications for black-hole hair and correlation functions. In particular, it is argued that the relation between correlation functions in the matrix model and in the Liouville approach is more complicated than often assumed.

2. Exactly Marginal Operators

2.1. The Terms of Order τ^2

In the approach of David, Distler and Kawaii (DDK), a conformal field theory with central charge c and Lagrangian $\mathcal{L}_m(x)$ coupled to 2D gravity is described by the action^[4,5]

$$S_0 = \frac{1}{8\pi} \int d^2\sigma \sqrt{\hat{g}} \{ \mathcal{L}_m(x) + (\partial\phi)^2 + Q \hat{R}\phi + \text{cosmological constant} + \text{ghosts} \} \quad (2.1)$$

with $Q = \sqrt{(25-c)/3}$ and conformal factor ϕ . The cosmological constant will be neglected at first, but included later. (See subsection 2.4.)

When $\mathcal{L}_m(x)$ is perturbed by operators $t^i \Phi_i(x)$, these operators get “dressed” upon coupling to gravity. As emphasized above, the dressed interaction must be an *exactly* marginal operator, not only an operator of dimension two. Exact marginality is needed, because in DDK’s approach the background metric \hat{g} corresponds to an arbitrary gauge choice that nothing physical should depend on. In particular, coupling

constants should not run with respect to \hat{g} : all beta functions must be zero to all orders.

In prior work, this condition has been exploited only to first order.^[4,5] Here it will be investigated in second order. Generally,^[13] the beta functions for a perturbed conformally invariant theory (see sect. 3.5 of part I),

$$S = S_0 + \tau^i \int d^2\sigma V_i, \quad \star$$

$$\text{are} \quad \beta^i = (\Delta_j^i - 2\delta_j^i) \tau^j + \pi c_{jk}^i \tau^j \tau^k + O(\tau^3), \quad (2.2)$$

if the V_i are primary fields of dimension Δ_i close to two. Δ_j^i is the dimension matrix computed with S_0 . If the operators V_k on the RHS of the operator algebra[†]

$$V_i(r)V_j(0) \sim \sum_k |r|^{-\Delta_i-\Delta_j+\Delta_k} c_{ij}^k V_k(0)$$

also have dimension close to two, the coefficients c_{ij}^k are universal constants, independent of the renormalization scheme used to compute them. Operators of other dimensions also appear on the RHS. For them, the c_{jk}^i are scheme-dependent, that is, not invariant under coupling constant redefinitions. Let us ignore them here.[‡]

We now show that $\beta^i = 0 + O(\tau^3)$ for the perturbation (1.1) plus (1.2):[§]

$$\delta S = \tau^i \int d^2\sigma V_i(x, \phi) \equiv \tau^i \int d^2\sigma \hat{V}_i(x, \phi) - \pi c_{ij}^k \tau^i \tau^j \int d^2\sigma X_k(x, \phi), \quad (2.3)$$

$$V_i = \hat{V}_i - \pi c_{ij}^k \tau^j X_k, \quad \hat{V}_i \equiv \Phi_i(x) e^{\alpha_i \phi}, \quad X_k \equiv -\frac{1}{Q + 2\alpha_k} \Phi_k(x) \phi e^{\alpha_k \phi}. \quad (2.4)$$

α_i is adjusted to make the dimension of \hat{V}_i exactly two. Without the $O(\tau)$ corrections

^{*} Here and below we omit powers of a length scale a , needed to make the τ^i dimensionless.

[†] keeping only the radial dependence on the RHS; the rest drops out after integrating over \vec{r} .

[‡] Presumably the scheme can be chosen so that they vanish.

[§] The question of the uniqueness of (1.2) is deferred to subsection 4.4.

in V_i , we would thus have $\Delta_j^i = 2\delta_j^i$ and $\beta = 0 + O(\tau^2)$ from (2.2). With them,

$$\Delta_j^i = 2\delta_j^i - \pi c_{kj}^i \tau^k + O(\tau^2), \quad (2.5)$$

hence $\beta = 0 + O(\tau^3)$ in (2.2). (2.5) can be derived by writing

$$X_k = -\frac{1}{Q + 2\alpha_k} \Phi_k(x) \frac{\partial}{\partial \alpha_k} e^{\alpha_k \phi},$$

defining the generator $L_0 + \bar{L}_0$ of global scale transformations, and differentiating with respect to α_k the dimension formula

$$\begin{aligned} (L_0 + \bar{L}_0)e^{\alpha_k \phi} &= -\alpha_k(\alpha_k + Q) e^{\alpha_k \phi}, \\ \Rightarrow (L_0 + \bar{L}_0)X_k &= 2X_k + \hat{V}_k \\ \Rightarrow (L_0 + \bar{L}_0)V_k &= 2V_k - \pi c_{jk}^i \tau^j V_i + O(\tau^2). \end{aligned}$$

As a simple check of all this, one can consider rescaling $\psi \rightarrow (1 + \lambda)\psi$ in

$$S_{\text{toy model}} = \frac{1}{8\pi} \int d^2\sigma ((\partial\psi)^2 + \gamma \cos \sqrt{2}\psi) \quad \text{with } \lambda \ll \gamma (\times a^2).$$

This should keep the interaction marginal at $O(\gamma\lambda)$ and is equivalent to adding the terms $2\lambda(\partial\psi)^2 - \sqrt{2}\lambda\gamma\psi \sin \sqrt{2}\psi$ to the Lagrangian. Using the above method, one can check that the second term indeed arises as the correction to the first term.¶

2.2. The Sine–Gordon model

As an example, consider an uncompactified scalar field x coupled to gravity. Then $c = 1$ and $Q = 2\sqrt{2}$. First, we perturb this model by the Sine–Gordon interaction,

$$S = \frac{1}{8\pi} \int d^2\sigma \sqrt{\hat{g}} \{(\partial x)^2 + (\partial\phi)^2 + 2\sqrt{2}\hat{R}\phi + \text{ghosts}\} + m \int d^2\sigma \cos px e^{(p-\sqrt{2})\phi}, \quad (2.6)$$

and determine the $O(m^2)$ corrections (2.3). To find the coefficients c_{ij}^k , consider the

¶ Here, $8\pi\hat{V}_1 = \cos \sqrt{2}\psi$, $8\pi\hat{V}_2 = 2(\partial\psi)^2$, $c_{12}^1 = c_{21}^1 = -2/\pi$ and $8\pi X_1 = -1/(2\sqrt{2}) \psi \sin \sqrt{2}\psi$.

operator product expansion (OPE), using the propagator $-\log r^2$:

$$\begin{aligned}
& \cos px e^{(p-\sqrt{2})\phi}(r) \quad \cos px e^{(p-\sqrt{2})\phi}(0) \\
& \sim |r|^{-2-4(p-\frac{1}{2}\sqrt{2})^2} e^{2(p-\sqrt{2})\phi} \left\{ \frac{1}{2} - |r|^2 \frac{p^2}{8} \partial x^2 + \dots \right\} \\
& + |r|^{-2+(4\sqrt{2}p-2)} \cos 2px e^{2(p-\sqrt{2})\phi} \left\{ \frac{1}{2} - |r|^2 \frac{p^2}{8} \partial x^2 + \dots \right\}
\end{aligned} \tag{2.7}$$

As mentioned, we must look for nearly quadratic singularities, so that the c_{jk}^i are universal constants. The second line in (2.7) has $|r|^{-2}$ singularities at the “discrete momenta” $p \in \{\dots, 0, \frac{1}{2}\sqrt{2}, \sqrt{2}, \dots\}^*$ and the third line at $p \in \{\dots, 0, \frac{1}{4}\sqrt{2}, \dots\}^{**}$. Let us study the neighborhoods of $p = \frac{1}{2}\sqrt{2}$ and $p = \sqrt{2}$. There the induced operators are:

$$\begin{aligned}
& \text{at } p = \frac{1}{2}\sqrt{2} + \delta : \quad \hat{V}_1 = e^{(2\delta-\sqrt{2})\phi} \quad \text{with } c_{mm}^1 = \frac{1}{2} \\
& \text{at } p = \sqrt{2} + \epsilon : \quad \hat{V}_2 = (\partial x)^2 e^{2\epsilon\phi} \quad \text{with } c_{mm}^2 = -\frac{p^2}{8}.
\end{aligned}$$

From (2.3) and (2.4), the leading order corrections to (2.6) are obtained:

$$\begin{aligned}
& \text{near } p = \frac{1}{2}\sqrt{2} : \quad \delta S = \frac{m^2\pi}{8\delta} \int d^2\sigma \phi e^{-\sqrt{2}\phi} \\
& \text{near } p = \sqrt{2} : \quad \delta S = -\frac{m^2\pi}{8\sqrt{2}} \int d^2\sigma \phi (\partial x)^2.
\end{aligned} \tag{2.8}$$

This will be further discussed in section 3. Note the factor δ^{-1} in the first line. Note also that from the string theory point of view, (2.8) describes the backreaction of the tachyon onto itself and the graviton.

* corresponding to the discrete tachyons $\Phi_{j,\pm j}$ of the next subsection

** However, for $p < \frac{1}{2}\sqrt{2}$ the operators on the RHS do not exist (see sect. 4.2 of part I). As a consequence, $\cos 2px$ terms are not induced and no phase transition occurs at those momenta, as argued in appendix B.

2.3. The Discrete $c = 1$ Operators

As a second example, consider perturbing the $c = 1$ model with the nonrenormalizable so-called (chiral) discrete primaries $\Phi_{jm}(x)$,^[34]

$$\Phi_{jm} = f_{jm}[\partial x, \partial^2 x, \dots] e^{im\sqrt{2}x} \equiv (H^-)^{j-m} e^{ij\sqrt{2}x} \quad (2.9)$$

with dimension j^2 and $SU(2)$ indices j, m , the $SU(2)$ algebra being generated by

$$H^\pm \sim \oint dz e^{\pm i\sqrt{2}x(z)} = \oint dz \Phi_{1,\pm 1}(z), \quad H^3 \sim \oint dz i\sqrt{2}\partial x(z) = \oint dz \Phi_{1,0}(z).$$

Here the integrations are along contours in the z plane that encircle the operators that H^\pm, H^3 act upon. If an interaction $t^{jm}\Phi_{jm}[x]\bar{\Phi}_{jm}[\bar{x}]$ is added to the matter Lagrangian, the dressed interaction is, to first order in the coupling constants,

$$\mathcal{L}_{int} = \tau^{jm} \hat{V}_{jm}, \quad \hat{V}_{jm} \equiv \Phi_{jm}(x)\bar{\Phi}_{jm}(\bar{x}) e^{\alpha_j(\phi+\bar{\phi})}$$

with $\alpha_j = (j-1)\sqrt{2}$. The Φ_{jm} can be rescaled such that the operator algebra of the \hat{V}_{jm} has the w_∞ structure^[24,25]

$$c_{kn}^{jm} c_{k'n'}^{j'm'} = (kn' - k'n)^2 \delta_{j,k+k'-1} \delta_{m,n+n'}.$$

From (2.3) and (2.4) one obtains the second-order interaction term

$$\delta\mathcal{L} = \sum_{j,m} \Phi_{jm}\bar{\Phi}_{jm} \phi e^{\alpha_j\phi} \times \frac{\pi}{2\sqrt{2}j} \sum_{\substack{j'+j''=j+1 \\ m'+m''=m}} (j'm'' - j''m')^2 \tau^{j'm'} \tau^{j''m''}. \quad (2.10)$$

$\mathcal{L}_{int} + \delta\mathcal{L}$ is marginal up to order $(\tau)^2$. Again, depending on the renormalization scheme, operators whose dimensions are not two may also appear in $\delta\mathcal{L}$.

2.4. Uniqueness and the Cosmological Constant

Next, we must ask whether the modifications (1.2) of the operators (1.1) are the unique modifications that achieve marginality up to order $(\tau)^2$. The situation is greatly clarified by thinking of the marginality conditions as equations of motion of string theory, as in ref. [6]. One concludes the following (more details are given in appendix A):

The marginality conditions are second-order differential equations in ϕ and x . Their solutions are unique after two boundary conditions are imposed, namely: (i): the modifications must vanish at $\phi = 0$, and (ii): the second, more negative of the two possible Liouville dressings (as e.g., in (A.5)) does not appear.

Boundary condition (i) comes about because the Liouville mode ϕ lives on a half line:^[6] The sum over geometries can be covariantly regularized as a sum over random lattices. Then no two points can come closer to each other than the lattice spacing a :

$$\hat{g}_{\mu\nu} e^{\alpha\phi} d\sigma^\mu d\sigma^\nu \geq a^2 \quad \Rightarrow \quad \phi \leq \phi_0 \quad \text{with} \quad e^{\alpha\phi_0} \propto a^2 \quad (2.11)$$

(recall that $\alpha < 0$.) After shifting ϕ so that $\phi_0 = 0$, boundary condition (i) states that the action $S(\phi = 0)$ at the cutoff scale is the bare action (see e.g., (A.4)).^[6] Boundary condition (ii) arises because operators with the more negative Liouville dressing do not exist (see sect. 4.2 of part I).

The correction terms found above obey the boundary conditions (i) and (ii) and are therefore unique. Of course, there is always an ambiguity due to field redefinitions, that is, choosing different renormalization schemes when computing the beta functions. There is no problem as long as we stick to one scheme.*

Another important question is how the cosmological constant modifies our results. The problem with the cosmological constant operator is that it cannot be made small in the IR ($\phi \rightarrow -\infty$). It can only be shifted in the ϕ direction. Thus it cannot be

* Actually, the scheme used in subsection 2.1 is not the same as the one used for the string equations of motion in appendix A, but this does not affect the above conclusions.

treated perturbatively, rather it should be included from the start in S_0 of (2.1). In its presence the OPE's used above are modified. Applying the discussions in refs. [6,18,20], one tentatively concludes the following (more details are given in appendix B):

1. The effects of the cosmological constant on gravitational dressings can be neglected in the ultraviolet ($\phi \sim 0$), but not in the infrared ($\phi \rightarrow -\infty$).

2. In the Sine-Gordon model coupled to gravity, no unwanted terms with $\cos 2px$ are induced because the OPE's are "softer" than in free field theory (see (A.4-5)).

These conclusions will be confirmed in section 3 by observing the agreement with matrix model results.

3. Running Coupling Constants

3.1. Renormalization Group Transformations

In subsections 3.1 and 3.2, the cosmological term will be assumed to be $\mu e^{-\sqrt{2}\phi}$ to simplify the discussion. This can be generalized to more complicated forms like $T_\mu(\phi)$ in (B.2).

Consider rescaling the cutoff $a \rightarrow ae^\rho$ in the path integral of 2D gravity,

$$\int_{\phi \geq \phi_0} D\phi Dx Db Dc e^{-S(\phi,x,b,c)}.$$

From (2.11) one sees that this induces a shift of the bound $\phi_0 \rightarrow \phi_0 + \lambda$, in addition to an ordinary RG transformation. From (2.11),

$$\lambda = \phi_0(ae^\rho) - \phi_0(a) = \frac{2}{\alpha}\rho = -\sqrt{2}\rho.^\dagger \quad (3.1)$$

In fact, since ordinary RG transformations are irrelevant (since all beta functions are zero), *only* the shift of the bound remains. The constant shift of the bound is

† More generally, $\rho = \frac{1}{2} \log \frac{T_\mu(\lambda)}{T_\mu(0)}$ with cosmological constant T_μ as in (B.2)

equivalent to a constant shift of the Liouville mode, $\phi \rightarrow \phi + \lambda$. Let us absorb this shift in “running coupling constants” $\bar{\tau}(\lambda)$, $\bar{\tau}_0 \equiv \bar{\tau}(0)$, defined by:

$$S[\bar{\tau}(\lambda), x, \phi + \lambda] = S[\bar{\tau}_0, x, \phi]. \quad (3.2)$$

After expressing λ in terms of ρ ,[‡] one obtains the renormalization group flow $\bar{\tau}(\rho)$. (For similar conclusions, see [35,36].)

As mentioned above, the action (3.2) corresponds to a classical solution of string theory with two-dimensional target space (x, ϕ) . The equations of motion of classical string theory thus play the role of the Gell-Mann–Low equations in the presence of gravity.^[35] They contain second- (and higher-) order derivatives of ϕ , which we have just interpreted as “renormalization group time.” It has been suggested that those are due to the contribution of pinched spheres in the functional integral over metrics.^[37]

3.2. Sine–Gordon Model near $p = \sqrt{2}$

We now apply the preceding procedure to the examples worked out in section 2, starting with the Sine–Gordon model. In flat space, at $p = \sqrt{2}$ the Kosterlitz–Thouless phase transition occurs. With gravity, at $p = \sqrt{2} + \epsilon$ the action is to order $(m, \epsilon)^2$ (see (2.8); we ignore $O(\mu)$ -corrections of the Sine–Gordon interaction):

$$S = \frac{1}{8\pi} \int d^2\sigma \sqrt{\hat{g}} \{ (\partial x)^2 + (\partial \phi)^2 + 2\sqrt{2}\hat{R}\phi + \text{ghosts} + \mu e^{-\sqrt{2}\phi} \} \\ + m \int d^2\sigma \cos(\sqrt{2} + \epsilon)x e^{\epsilon\phi} - \frac{\pi}{8\sqrt{2}} m^2 \int d^2\sigma \phi (\partial x)^2. \quad (3.3)$$

To $O(m, \epsilon)^2$, a shift $\phi \rightarrow \phi + \lambda$ can be absorbed in the λ -dependent couplings

$$m(\lambda) = m_0 e^{-\epsilon\lambda}, \quad \epsilon(\lambda) = \epsilon_0 - \frac{\pi^2}{2} \lambda m^2, \quad \mu(\lambda) = \mu_0 e^{\sqrt{2}\lambda}.$$

In deriving $\epsilon(\lambda)$, the $\lambda m^2 (\partial x)^2$ term has been absorbed in a redefinition of x and then

[‡] This is more complicated with T_μ , but to find phase boundaries, $\bar{\tau}(\lambda)$ will be good enough.

in a shift of ϵ . Defining ‘prime’ as $\frac{d}{d\lambda}$, we get

$$\epsilon' = -\frac{\pi^2}{2}m^2 + \dots, \quad m' = -\epsilon m + \dots, \quad \mu' = \sqrt{2}\mu + \dots$$

Defining ‘dot’ as $\frac{d}{d\rho} = -\sqrt{2}\frac{d}{d\lambda}$ yields the beta functions

$$\dot{\epsilon} = \frac{\pi^2}{\sqrt{2}}m^2, \quad \dot{m} = \sqrt{2}\epsilon m, \quad \dot{\mu} = -2\mu. \quad (3.4)$$

$\dot{\mu}$ serves as a check: μ decays in the UV according to its dimension (two). The coupling constant flow is qualitatively the same as in flat space and is given by the Kosterlitz–Thouless diagram (Figure 1). We see that the $m^2\phi(\partial x)^2$ correction in (3.3), which is an example of the corrections (1.2) to (1.1), plays a crucial role: ignoring it would be like forgetting about field renormalization in the ordinary Sine-Gordon model.

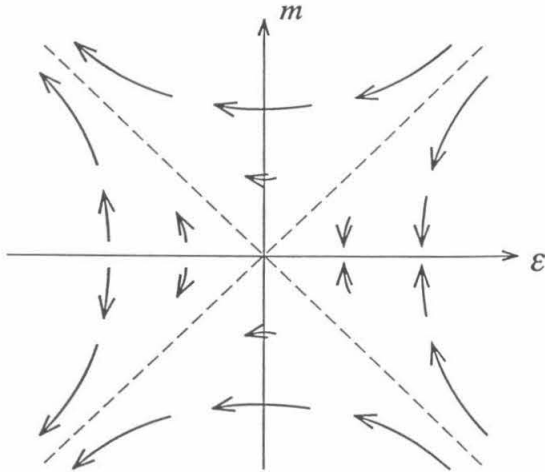

fig.1:

KT-transition with gravity at $O(\epsilon, m)^2$ (Arrows point towards infrared).

From (3.4), the phase boundary for $p > \sqrt{2}$ is linear, $m \propto \epsilon$. To this order, this agrees with the matrix model result [31]

$$m \propto \epsilon e^{\frac{1}{2}\sqrt{2}\epsilon \log \epsilon}. \quad (3.5)$$

With the normalization of m and ϵ as in (3.3), we obtain the slope $\sqrt{2}/\pi$ for the phase boundary. After comparing the normalizations, this should also be checked with the matrix model. It will also be interesting to see if the logarithm in (3.5) follows from the modifications of higher order in m , needed to keep the interaction near $p = \sqrt{2}$ marginal beyond $O(m^2)$.

We can now interpret the phase diagram of [31] (figure 2) near $m, \epsilon = 0$: For $\epsilon < 0$ (regions II and V of [31]), m grows exponentially towards the IR. The model thus flows to (infinitely many copies of) the $c = 0$, pure gravity model.[36,38]

For $\epsilon > 0$, but m greater than a critical value $m_c(\epsilon)$ (region VI of [31]), the flow goes again towards the $c = 0$ model in the IR. For $m < m_c(\epsilon)$ (region III of [31]) the flow seems to go to the free $c = 1$ model. However, the domain of small ϵ, m is now the IR domain. As noted in subsection 2.4, the cosmological constant cannot be neglected there and further investigation is needed.

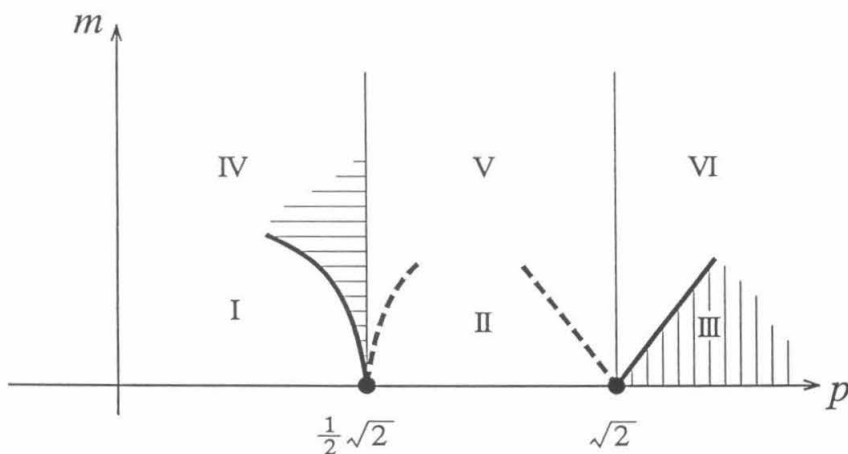

fig.2:

Regions of the Sine-Gordon model with gravity at $O(m^2)$.

3.3. Sine–Gordon Model near $p = \frac{1}{2}\sqrt{2}$

At $p = \frac{1}{2}\sqrt{2} + \delta$, the situation is less clear. From (2.8), instead of the $(\partial x)^2$ term a “1” term is induced. That is, the cosmological constant is modified by the induced operator $\phi e^{-\sqrt{2}\phi}$. The latter becomes comparable with the background cosmological constant at $\delta \sim \frac{m^2}{\mu}$. Let us tentatively^{*} write the action to leading order as:

$$S = \frac{1}{8\pi} \int d^2\sigma \sqrt{\hat{g}} \{ (\partial x)^2 + (\partial\phi)^2 + 2\sqrt{2}\hat{R}\phi + \text{ghosts} \} \\ + m \int d^2\sigma \cos\left(\frac{1}{2}\sqrt{2} + \delta\right)x e^{(-\frac{1}{2}\sqrt{2} + \delta)\phi} + \left(\frac{\mu}{8\pi} + \frac{m^2\pi}{8\delta}\right) \int d^2\sigma \phi e^{-\sqrt{2}\phi}. \quad (3.6)$$

With our normalizations, the effective cosmological constant is now $\mu + \frac{m^2}{\delta}\pi^2$. For fixed μ , it blows up as $|\delta| \rightarrow 0$. For $\delta < 0$ and $m \geq \frac{1}{\pi}\sqrt{|\mu\delta|}$, it is negative. Indeed, in the matrix model a singularity of the free energy has been found at

$$\delta < 0, \quad m \propto \sqrt{|\mu\delta|} e^{\frac{1}{2}\sqrt{2}\delta \log \delta}. \quad (3.7)$$

Let us therefore identify the region where $\mu + \frac{m^2}{\delta}\pi^2$ is negative with region IV of [31]. We leave a further interpretation of the situation near $p = \frac{1}{2}\sqrt{2}$ for the future.

3.4. The Discrete Operators

We can also determine the one–loop beta function for the “discrete” interactions (2.9) of subsection 2.3. From (2.10),

$$\mathcal{L} + \delta\mathcal{L} = \sum_{j,m} \Phi_{jm} \bar{\Phi}_{jm} e^{(j-1)\sqrt{2}\phi} \{ \tau^{jm} + \phi \frac{\pi}{2\sqrt{2}j} \sum_{\substack{j'+j''=j+1 \\ m'+m''=m}} (j'm'' - j''m')^2 \tau^{j'm'} \tau^{j''m''} \}.$$

Constant shifts $\phi \rightarrow \phi + \lambda$ are absorbed up to $O(\tau^2)$ in:

$$\tau^{jm}(\vec{\tau}_0, \lambda) = \{ \tau_0^{jm} - \lambda \times \frac{\pi}{2\sqrt{2}j} \sum_{\substack{j'+j''=j+1 \\ m'+m''=m}} (j'm'' - j''m')^2 \tau_0^{j'm'} \tau_0^{j''m''} \} e^{-(j-1)\sqrt{2}\lambda}.$$

^{*} Here we use $\phi e^{-\sqrt{2}\phi}$ instead of the simple form $e^{-\sqrt{2}\phi}$ for the cosmological constant (see refs. [18,20]).

From this we find the one-loop beta function (using (3.1)):

$$\dot{\tau}^{jm} = 2(j-1)\tau^{jm} + \frac{\pi}{2j} \sum_{\substack{j'+j''=j+1 \\ m'+m''=m}} (j'm'' - j''m')^2 \tau^{j'm'} \tau^{j''m''} + O(\tau^3). \quad (3.8)$$

Thus, turning on the operators $\Phi_{jm} \bar{\Phi}_{j'm'}$ with $j' > 1$ will in general induce an infinite set of higher spin operators $\Phi_{jm} \bar{\Phi}_{jm}$ at $O(\tau^2)$, whose couplings were originally turned off. This is what one expects from these nonrenormalizable operators, but it would not happen without the $O(\tau^2)$ modification $\delta\mathcal{L}$.

4. Outlook

4.1. Correlation Functions

The modifications (1.2) are important not only for understanding the renormalization group flow but also for computing correlation functions in Liouville theory. They imply the identification (the notation is as in (2.4)):

$$\langle \exp\left\{ \int t^i \Phi_i \right\} \rangle_G \sim \langle \exp\left\{ \int (\tau^i \hat{V}_i + \kappa_l c_{ij}^l \tau^i \tau^j \phi \hat{V}_l + \dots) \right\} \rangle_L, \quad (4.1)$$

where $\langle \dots \rangle_G$ and $\langle \dots \rangle_L$ denote correlation functions computed in the matrix model (Gravity) and in Liouville theory, respectively, and $\kappa_l = \pi/(Q + 2\alpha_l)$. τ^i is related to the t^j in some nontrivial way: $\tau^i = t^i + O((t)^2)$.^[21]

Geometrically, the extra terms on the RHS can be interpreted as arising from pinched spheres in the sum over surfaces. (4.1) has consequences for the correspondence of matrix model and Liouville correlation functions. Expanding both sides and temporarily identifying t and τ^\dagger yields e.g, for the two-point function:

$$\langle \int \Phi_i \int \Phi_j \rangle_G = \int d^2z \int d^2w \langle \hat{V}_i(z) \hat{V}_j(w) \rangle_L + 2\kappa_l c_{ij}^l \int d^2w \langle \phi \hat{V}_l(w) \rangle_L. \quad (4.2)$$

In fact, the last term is necessary for background invariance: Inserting a covariant

† The nontrivial relation between τ and t noted in [21] corresponds to the appearance of operators \hat{V}_i (instead of $\phi \hat{V}_i$) on the RHS of (4.1). They are also present, but let us here focus on the new type of operators $\phi \hat{V}_i$.

regulator like $\Theta(\sqrt{\hat{g}}e^\phi|z - w|^2 - a^2)$ into the two-point function induces new background dependence, coming from the integration region $z \sim w$.^[13] By construction, the one-point functions added in (4.2) are precisely what is needed to cancel this dependence.

Additional terms like the ones in (4.2) are also present in higher point functions. They can be determined by background invariance. It should be possible to see them in matrix model computations, e.g., of higher-point functions of tachyons at the “discrete” momenta. It then needs to be better understood why we can recover some of the matrix model correlators with the method of Goulian and Li from the Liouville correlators,^[15,16,26] without the extra terms in (4.2).

4.2. Black Hole Hair

The conjecture that all the discrete operators, in particular the ‘static’ ones $\Phi_{j,0}$ with zero x -momentum can be turned into exactly marginal ones implies that each $\Phi_{j,0}$ adds a new dimension to the space of black hole solutions of classical 2D string theory, corresponding to higher spin (not only metric) hair. It will be very interesting to better understand how significant this is for the issue of information loss in black holes.^[39]

4.3. Four Dimensions

It would also be interesting to extend this work to four dimensions. Four-dimensional Euclidean quantum geometry is, at the least, an interesting statistical mechanical model. In part III, we show that at the ultraviolet fixed point of infinite Weyl coupling, where the theory is asymptotically free,^[40] it can be solved with the methods of two-dimensional quantum gravity in conformal gauge.^[41] Perturbing away from this limit is similar to adding perturbations to the free $c = 1$ theory. One might be able to find a phase diagram for Euclidean quantum gravity by generalizing the method suggested here.

4.4. Summary

In the Liouville theory approach to 2D quantum gravity coupled to an interacting scalar field, new terms appear in the Lagrangian at higher orders in the coupling constants. They are required by background independence and cannot be eliminated by a field redefinition when the interaction is given by one of the discrete tachyons or higher-spin operators.

The new terms are crucial for obtaining the correct phase diagram, as found with the nonperturbative matrix model techniques in the case of the Sine–Gordon model. We have partly interpreted this diagram, but the transition below $p = \frac{1}{2}$ of the Kosterlitz–Thouless momentum must be clarified more. The cosmological constant must be treated more rigorously, and the cubic terms in the beta function (2.2), which are also universal, should be derived. The new terms have various other implications and should, in particular, be important for the correct computation of higher-point correlation functions.

APPENDICES

Appendix A: String Equations of Motion and Boundary Conditions

The question addressed here is whether (1.2) are the unique modifications that make the interaction (1.1) marginal up to order τ^2 . It is useful to think of 2D quantum gravity as classical string theory.^[6] Let us first discuss the example of the Sine–Gordon model. The discussion will be restricted to genus zero.

It is well known that, for genus zero, exactly marginal perturbations of the world-sheet action correspond to classical solutions of string theory. Some of them can be

found by expanding in powers of m the dilaton Φ , the graviton $G_{\mu\nu}$ and the tachyon T in the sigma model

$$S = \frac{1}{8\pi} \int d^2\sigma \sqrt{\hat{g}} \{G_{\mu\nu}(x, \phi) \partial x^\mu \partial x^\nu + \hat{R}\Phi(x, \phi) + T(x, \phi)\} \quad \text{in } m: \star \quad (\text{A.1})$$

$$\begin{aligned} T(x, \phi) &= m \cos px e^{(p-\sqrt{2})\phi} + m^2 T^{(1)}(x, \phi) + \dots \\ \Phi(x, \phi) &= 2\sqrt{2}\phi + m^2 \Phi^{(1)}(x, \phi) + \dots \\ G_{\mu\nu}(x, \phi) &= \delta_{\mu\nu} + m^2 h_{\mu\nu}(x, \phi) + \dots \end{aligned} \quad (\text{A.2})$$

and by then solving the equations of motion derived from the low-energy effective action of two-dimensional string field theory,^[7,42]

$$\int dx d\phi \sqrt{G} e^\Phi \{R + \nabla\Phi^2 + 8 + \nabla T^2 - 2T^2 + \frac{4}{3}T^3 + O(m^4)\}.$$

The corrections to G, Φ in (A.2) are of order m^2 because T appears in the Hilbert-Einstein equations only in the tachyon stress tensor, which is quadratic in T . The T^3 term is ambiguous,^[42,43] but this will not be important here. It is useful to choose a gauge in which the dilaton is linear, i.e., $\Phi^{(1)} = 0$.[†] To $O(m^2)$, the equations of motion are second-order differential equations:

$$\begin{aligned} \nabla_\mu \nabla_\nu \Phi - \frac{1}{2} G_{\mu\nu} (\vec{\nabla}\Phi^2 + 2 \square\Phi - 8) &= \Theta_{\mu\nu} \\ \square T + \vec{\nabla}\Phi \vec{\nabla}T + 2T - 2T^2 &= 0 \end{aligned} \quad (\text{A.3})$$

with tachyon stress tensor $\Theta_{\mu\nu}$.

To specify a solution, we need two boundary conditions. Following ref. [6], we will adopt boundary conditions given (i) in the ultraviolet by the bare action and (ii) in the infrared by the requirement of regularity. Let us for now assume the simple form $e^{\alpha\phi}$ for the cosmological constant. ‘Infrared’ means $\phi \rightarrow -\infty$ since $\alpha = -\sqrt{2} < 0$.

^{*} The cosmological constant will be included in the tachyon in appendix B.

Its presence justifies the expansion in m .

[†] This is always possible at least at order m^2 and m^3 .

(i) UV: As pointed out in (2.11), the Liouville coordinate is bounded:

$$\hat{g}_{\mu\nu} e^{\alpha\phi} d\xi^\mu d\xi^\nu \geq a^2 \Rightarrow \phi \leq \phi_0 \sim \frac{1}{\alpha} \log a^2.$$

This bound on ϕ does not modify the Einstein equations.[‡] It just requires specifying the action at the cutoff, $S(\phi = \phi_0)$. As in [6], we identify it with the unperturbed action S_0 plus the bare matter interaction (Δ is the bare cosmological constant:)

$$S(\phi = \phi_0) = S_0 + \frac{1}{8\pi} \int d^2\sigma (\Delta + m_B \cos px) \Leftrightarrow \begin{cases} T(\phi_0) = \Delta + m_B \cos px \\ G_{\mu\nu}(\phi_0) = \delta_{\mu\nu} \end{cases} \quad (A.4)$$

(ii) IR: It has been pointed out^[18,20] that operators that diverge faster than $e^{-Q/2 \phi}$ as $\phi \rightarrow -\infty$ do not exist in the Liouville theory (2.1). This provides the second boundary condition. Given one solution of (A.3) for $T^{(1)}$ and $h_{\mu\nu}$, the other solutions are obtained by adding linear combinations of $O(m^2)$ of the on-shell tachyons and the two discrete gravitons

$$\cos px e^{(p-\sqrt{2})\phi}, \quad \cos px e^{(-p-\sqrt{2})\phi}, \quad (\partial x)^2 \quad \text{and} \quad (\partial x)^2 e^{-2\sqrt{2}\phi}. \quad (A.5)$$

Boundary condition (ii) means essentially that the operators with the more negative Liouville dressing must be dropped. For a more precise statement, see appendix B.

So far, the discussion has been restricted to the tachyon and the graviton. Including the discrete operators of subsection 2.3 as interactions corresponds to turning on higher spin backgrounds in the sigma model, and the same arguments seem to apply. That two boundary conditions still suffice to specify a solution is suggested by the fact that there are only two possible Liouville dressings for each of the discrete operators of the $c = 1$ model.

Setting the bound $\phi_0 = 0$, we see that the operators found in section 2 already satisfy the boundary conditions (i) and (ii), and are thus the unique marginal perturbations.

[‡] The implicit assumption here is that the term $\log \sqrt{\hat{g}}$ in the definition of ϕ_0 is absorbed in the gravitational dressing of the operators. Otherwise ϕ_0 varies with \hat{g} and we can no longer expect that the perturbations are (1,1), let alone exactly marginal.

Appendix B: The Cosmological Constant

Gravitational dressings in the presence of a cosmological constant μ can in principle be found as follows (see [6,20] for some details). One includes the cosmological constant in the tachyon of string theory, replacing e.g., for the Sine–Gordon model, the ansatz (A.2) by

$$\begin{aligned} T(x, \phi) &= T_\mu(\phi) + m \cos px f_\mu(p, \phi) + m^2 T_\mu^{(1)}(x, \phi) + .. \\ G_{\alpha\beta}(x, \phi) &= \delta_{\alpha\beta}^\mu(\phi) + m^2 h_{\alpha\beta}^\mu(x, \phi) + .. \end{aligned} \quad (B.1)$$

where T_μ is the cosmological constant and f_μ , $T_\mu^{(1)}$ and h^μ are the modified dressings, exact in μ order by order in m .[§] Let us assume that $m \ll \mu$, but that both are small.

First, one must find T_μ and δ^μ exactly. T_μ has the form of a kink centered at a free parameter $\bar{\phi}$, related to μ by $\mu = e^{\sqrt{2}\bar{\phi}}$ and to the bare cosmological constant Δ by $\Delta \propto \bar{\phi} e^{\sqrt{2}\bar{\phi}}$: [6]

$$T_\mu(\phi) = T_0(\phi - \bar{\phi}), \quad T_0(\phi) = \begin{cases} 1 & \text{for } \phi \rightarrow -\infty \\ \propto \phi e^{-\sqrt{2}\phi} & \text{for } \phi \rightarrow \infty \end{cases} \quad (B.2)$$

(B.2) satisfies the boundary conditions (i), $T_\mu(0) = \Delta$ (by definition of Δ) and (ii), T_μ does not diverge as $\phi \rightarrow -\infty$ ($T \rightarrow 1$). δ^μ differs from δ because of the backreaction of the tachyon T_μ on the metric. Like T_μ , this difference decays exponentially in the UV.

Next, one must find the dressings f_μ , $T_\mu^{(1)}$ and h^μ by solving the string equations of motion (A.3) order by order in m . E.g., the tachyon equation of motion, linearized around the background T_μ , determines f_μ :^[6]

$$\{\partial_\phi^2 + 2\sqrt{2}\partial_\phi + 2 - p^2 - 4T_\mu\}f_\mu = 0. \quad (B.3)$$

Since T_μ and δ^μ are very small in the UV ($\bar{\phi} \ll \phi < 0$), the equations of motion for f_μ , $T_\mu^{(1)}$ and h^μ are the same as for $\mu = 0$ in this regime and the only role of

§ Although we cannot expand in μ , for $\mu > 0$ we can expand in m .

the cosmological constant is to set the second boundary condition (ii) of appendix A. E.g., the solutions of (B.3) in the UV are^[6]

$$c_1 e^{(-p-\sqrt{2})\phi} + c_2 e^{(+p-\sqrt{2})\phi} \propto e^{-\sqrt{2}\phi} \sinh(p\phi - \Theta).$$

In the IR region $\phi \ll \bar{\phi}$, where $T_\mu \sim \text{constant}$, the solution of (B.3) that is regular at $\phi \rightarrow -\infty$ grows exponentially. The other, divergent solution does not exist as an operator. To match the solutions for $\phi < \bar{\phi}$ and $\phi > \bar{\phi}$, one needs roughly $\Theta \sim p\bar{\phi}$. In the UV, $\phi - \bar{\phi}$ is large, of order $|\log a^2|$. So unless p is close to zero, f_μ is just $e^{(p-\sqrt{2})\phi}$ there. Boundary condition (ii) then simply means dropping the term with the second Liouville dressing, as without cosmological constant. At $O(m^2)$, the same arguments can be repeated for $T_\mu^{(1)}$ and h^μ .

Next, let us discuss OPE's in the presence of the cosmological constant. In free field theory, the OPE of two operators with Liouville momenta α, β would produce an operator with Liouville momentum $\alpha + \beta$. But in Liouville theory momentum is not conserved because of the exponential potential. Also, if $\alpha + \beta < -Q/2$, the operator $e^{(\alpha+\beta)\phi}$ does not exist. Instead, new primary fields $V_\sigma = e^{-Q/2 \phi} \sin(\sigma\phi + \Theta)$ will be produced, with some weight $f(\sigma)$ and less singular coefficients:^[20]

$$e^{\alpha\phi(r)} e^{\beta\phi(0)} \sim \int_0^\infty d\sigma |r|^{-2\alpha\beta + (\alpha+\beta+Q/2)^2 + \sigma^2} f(\sigma) V_\sigma \quad (B.4)$$

instead of $|r|^{-2\alpha\beta} e^{(\alpha+\beta)\phi}$.

For the Sine–Gordon model, this modification of the OPE's seems to cure the problem of new $|r|^{-2}$ singularities that would naively appear in (2.7) below $p = \frac{1}{2}\sqrt{2}$. They would give rise to unwanted counterterms like $\cos 2px$ at $p = \frac{1}{4}\sqrt{2}$ and $(\partial x)^2 \cos 2px$ at $p = 0$. The modified OPE of $\cos px e^{\epsilon\phi}$ with itself produces

$$\int \frac{d\sigma}{2\pi} f(\sigma) |r|^{-2+4p^2+\sigma^2} \cos 2px V_\sigma(\phi) + \dots \quad (B.5)$$

Except for the (negligible) case $p = \sigma = 0$, all singularities are milder than quadratic.

PART III: A 4D ANALOG OF 2D GRAVITY^{*}

1. Introduction

In parts I and II, a theory of two-dimensional quantum gravity in conformal gauge has been developed. It is natural to ask how much can be learned from this about four-dimensional quantum gravity. Here the following answer will be given: A natural analog of two-dimensional gravity is four-dimensional gravity with the action

$$S = \int_M d^4x \sqrt{g} \{ \lambda + \gamma R + \eta R^2 + \rho W^2 \} \quad (1.1)$$

in the limit of infinite Weyl coupling,

$$\rho \rightarrow \infty. \quad (1.2)$$

Here, M is a manifold of fixed topology, λ and γ are the cosmological and the inverse Newtonian constants, R is the Ricci-scalar, and W is the Weyl tensor, the traceless part of the Riemann tensor:

$$W_{\mu\nu\sigma\tau} = R_{\mu\nu\sigma\tau} - \frac{1}{2}(g_{\mu\sigma}R_{\nu\tau} + g_{\nu\tau}R_{\mu\sigma} - g_{\mu\tau}R_{\nu\sigma} - g_{\nu\sigma}R_{\mu\tau}) + \frac{1}{6}(g_{\mu\sigma}g_{\nu\tau} - g_{\mu\tau}g_{\nu\sigma})R.$$

It will be seen that in the limit (1.2) the path integral over the metric reduces to an integral over the conformal factor and a moduli space, as in two dimensions. As a consequence, most of the developments described in part I and II have four-dimensional analogs. In particular, the analog of the $c = 1$ barrier of two-dimensional gravity will be derived below, as well as scaling laws that can be compared with computer simulations. On the other hand, all the important features in four-dimensional gravity that go beyond those present in the limit $\rho \rightarrow \infty$ do not seem to have two-dimensional analogs.

^{*} based on a paper published in Nuclear Physics B 390, 188 (1993)

Apart from the fact that the theory (1.1) in the limit $\rho \rightarrow \infty$ can be studied with the methods of part I and II, is it of any interest otherwise? (1.1) is the most general local, renormalizable action of four-dimensional gravity, up to topological invariants. One interesting aspect of the limit (1.2), first pointed out by Fradkin and Tseytlin,^[40] is that, at least for $\eta = 0$, it is an ultraviolet fixed point of (1.1). It could thus be viewed as a “short-distance phase” of fourth-order derivative gravity.

But of course there is a well-known ghost problem common to all fourth-order derivative actions like (1.1): we can rewrite them in terms of new fields with two derivatives only, but some of them will have the wrong sign in the kinetic term. With Minkowskian signature this leads to nonunitarity. For this reason, let us consider (1.1) only in Euclidean space, as a (still interesting) statistical mechanical model of quantum geometry, or “three-branes.” In the future it will hopefully be possible to extract information about the physically interesting case in Minkowski space, $\rho = \eta = 0$, by means of a $1/\rho$ -expansion.

In section 2 we define (1.1) in the limit (1.2) rigorously by introducing a Lagrange multiplier p . That is, we begin by studying the path integral

$$\int Dg Dp \exp\left\{-\int_M d^4x \sqrt{g}(\lambda + \gamma R + \eta R^2 + ipW_+)\right\}. \quad (1.3)$$

In section 6 we show that this theory is the limit (1.2) of (1.1). Here, W_{\pm} is the (anti-) self-dual part of the Weyl tensor

$$W_{\pm}{}_{\mu\nu\sigma\tau} \equiv \frac{1}{2}(W_{\mu\nu\sigma\tau} \pm \frac{1}{2}\epsilon_{\mu\nu}{}^{\alpha\beta}W_{\alpha\beta\sigma\tau}).$$

The Lagrange multiplier p is a 4th rank self-dual tensor field which (like W_+) transforms as a (2,0) representation of the Euclideanized Lorentz group $SO(4) \sim SU(2) \times SU(2)$, i.e., like a spin 2 field.

In section 2, (1.3) will be rewritten as an integral over a moduli space and over the conformal factor ϕ , with a few determinants in this gravitational background.

The moduli space is that of conformally self-dual metrics and plays a role analogous to the moduli space of Riemann surfaces in two-dimensional gravity.

As in two dimensions, the determinants can be decoupled from ϕ by introducing a 4D analog of the Liouville action. Its form has recently been found in [45]. It consists of a free 4th order derivative piece (essentially $\phi \square^2 \phi$) plus pieces that renormalize λ, γ and η in (1.3), as explained in section 3. The proposal of DDK, explained in part I, is generalized to four dimensions in section 4. The cosmological constant, the Hilbert-Einstein term and the R^2 term each become exactly marginal operators of the new theory, but so far I have explored this only to lowest order.

In section 5 the fixed volume and fixed average curvature partition functions and the correlation functions of local operators in their dependence on the cosmological constant are derived, as has been done in two dimensions. It would be very interesting to explore whether the condition $W_+ = 0$ can be imposed in computer simulations of random triangulations, or whether – equivalently – the limit (1.2) can be taken. Then the predictions (5.11) could be compared with “experiment.” The analog of the $c = 1$ barrier is also given, in (5.3). In contrast with two dimensions, it is not crossed by adding too much matter.

In section 6, the theory, which we call “conformally self-dual gravity,” is discussed as the limit (1.2) of (1.1). It is also suggested that conformally self-dual gravity is connected with four dimensional topological gravity,^[23] as in the two dimensional case.^[47]

Part of our analysis is concerned with the four dimensional analog of the Liouville action and of DDK. In a different context the induced action for the conformal factor and its renormalization have also been studied recently by Antoniadis and Mottola.^[45] I have used some of their calculations. However, when I discuss the four-dimensional analog of DDK’s method of decoupling the conformal factor from its measure, my treatment and my conclusions will differ from those of [45]. I will state the main differences.

2. Conformal Gauge

The Lagrange multiplier p in (1.3) restricts the path integral over g to conformally self-dual metrics, i.e., metrics with $W_+ = 0$. W_+ has five independent components and the condition $W_+ = 0$ is Weyl and diffeomorphism invariant. So, up to a finite number of moduli, the five surviving components of the metric are the conformal factor and the diffeomorphisms. Let m_i parametrize the moduli space of conformally self-dual metrics modulo diffeomorphisms $x \rightarrow x + \xi$ and Weyl transformations $g \rightarrow ge^\phi$. Let us fix a representative $\hat{g}(m_i)$ via, say, the condition $\hat{R} = 0$ and Lorentz gauge $\partial^\mu \hat{g}_{\mu\nu} = 0$, and let us pick a conformally self dual metric

$$g_0 = (\hat{g}(m_i)e^\phi)^\xi, \quad (2.1)$$

where ξ indicates the action of a diffeomorphism. At g_0 we can split up a fluctuation of g :

$$\delta g_{\mu\nu} = g_{0\mu\nu} \delta\phi + \nabla_{(\mu} \delta\xi_{\nu)} + \delta\bar{h}_{\mu\nu}.$$

The four $\delta\xi$'s generate infinitesimal diffeomorphisms and the five $\bar{h}_{\mu\nu}$ parametrize the space of metrics perpendicular to ξ , ϕ and the moduli, i.e., perpendicular to the conformally self-dual ones. The measure for g is defined, in analogy to two dimensions^[3], by

$$\|\delta g\|^2 \equiv \int d^4x \sqrt{g} (4(\delta\phi + \frac{1}{2}\nabla^\mu \delta\xi_\mu)^2 + (L\delta\xi)^2 + (\delta\bar{h})^2) \quad (2.2)$$

with

$$(L\delta\xi)_{\mu\nu} \equiv \nabla_{(\mu} \delta\xi_{\nu)} - \frac{1}{2}g_{\mu\nu} \nabla^\rho \delta\xi_\rho. \quad (2.3)$$

Apart from restricting the path integral, integrating out p and \bar{h} in (1.3) will contribute the determinant

$$\det(O^\dagger O)_{g_0}^{-\frac{1}{2}} \quad (2.4)$$

where O^\dagger is the linearized W_+ -term

$$(O^\dagger_{g_0} \bar{h})_{\mu\nu\sigma\tau} \equiv \lim_{\epsilon \rightarrow 0} \frac{1}{\epsilon} (W_{+ \mu\nu\sigma\tau}[g_0 + \epsilon \bar{h}] - W_{+ \mu\nu\sigma\tau}[g_0]), \quad (2.5)$$

O is its adjoint and $O^\dagger O$ is a 4th order, conformally invariant, linear differential operator in the curved background g_0 , acting on p of (1.3).

We are left with an integral over the conformal equivalence class of each \hat{g} . From (2.2) it is seen that changing variables from g to ϕ and ξ in this equivalence class leads to a Jacobian

$$(\det L^\dagger L)_{\hat{g}}^{\frac{1}{2}},$$

where the zero modes of the operator L , defined in (2.3), have to be projected out. After dropping the integral over the diffeomorphism group $D\xi$ (since, in the absence of other gauge field backgrounds, gravitational anomalies can occur only in $4k + 2$ dimensions^[8]), the path integral (1.3) reduces to an integral over the moduli space of conformally self-dual metrics and ϕ :

$$\int \prod_i dm_i D\phi (\det O^\dagger O)_{\hat{g}e^\phi}^{-\frac{1}{2}} (\det L^\dagger L)_{\hat{g}e^\phi}^{\frac{1}{2}} (\det \Delta)_{\hat{g}e^\phi}^{-\frac{1}{2}} e^{-\int d^4x \sqrt{g}(\lambda + \gamma R + \eta R^2)}, \quad (2.6)$$

where free, conformally invariant matter fields have been added to the theory for generality, and their partition function has been denoted by $\det(\Delta)^{-\frac{1}{2}}$. Despite the notation, let us allow the matter to be fermions, Yang-Mills fields, etc., as well as conformally coupled scalars.

The moduli space of conformally self-dual metrics is a very interesting subject by itself which will not be discussed here. On the four sphere its dimension is zero: all conformally self-dual metrics on S^4 are conformally flat. On K^3 , its dimension is 57.^[48]

3. Liouville in 4D

Let us now decouple the determinants in (2.6) from ϕ . For conformally invariant differential operators X :^{*}

$$\det X_{\hat{g}e^\phi} = \det X_{\hat{g}} e^{-S_i[\hat{g}, \phi]} \quad (3.1)$$

where the induced action S_i is obtained by integrating the trace anomaly of the stress tensor [9]

$$-2 \frac{\delta S_i[\hat{g}, \phi]}{\delta \phi} = \sqrt{g} \langle T_\mu^\mu \rangle = \frac{1}{16\pi^2} \sqrt{g} [a(F + \frac{2}{3} \square R) + bG] - 4\lambda' \sqrt{g} - 2\gamma' \sqrt{g} R \quad (3.2)$$

where

$$F = W_+^2 + W_-^2$$

is the square of the Weyl tensor. (3.2) has, apart from the divergent parameters λ' and γ' , two finite parameters a, b . $\sqrt{g}G$ is the Gauss-Bonnet density,

$$G = R^{\mu\nu\sigma\tau} R_{\mu\nu\sigma\tau} - 4R^{\mu\nu} R_{\mu\nu} + R^2,$$

whose integral over the manifold is proportional to the Euler characteristic. Following Antoniadis and Mottola,^[45] (3.2) can easily be integrated by noting that with $g = \hat{g}e^\phi$ the combination

$$\sqrt{g}(G - \frac{2}{3} \square R) = \sqrt{\hat{g}} \hat{M} \phi + \sqrt{\hat{g}} (\hat{G} - \frac{2}{3} \hat{\square} \hat{R})$$

is only linear in ϕ with the fourth-order differential operator

$$\begin{aligned} \hat{M} &\equiv 2 \hat{\square}^2 + 4\hat{R}^{\mu\nu} \hat{\nabla}_\mu \hat{\nabla}_\nu - \frac{4}{3} \hat{R} \hat{\square} + \frac{2}{3} (\hat{\nabla}^\mu \hat{R}) \hat{\nabla}_\mu \\ &= 2 \hat{\square}^2 + 4\hat{R}^{\mu\nu} \hat{\nabla}_\mu \hat{\nabla}_\nu \quad \text{if } \hat{R} = 0 \\ &= 2 \hat{\square}^2 \quad \text{if } \hat{g}_{\mu\nu} = \delta_{\mu\nu} e^{\phi_0}. \end{aligned} \quad (3.3)$$

$\sqrt{g}F$ is independent of ϕ and $\sqrt{g} \square R$ is just the variation of the R^2 action with respect to ϕ . So the four-dimensional analog of the Liouville action consists of a free part plus a cosmological constant term, a Hilbert-Einstein term and an R^2 term:

* More precisely, if $X \equiv M^\dagger M$, M has to transform as $e^{p\phi} M e^{q\phi}$ under $g \rightarrow ge^\phi$.

$$S_i[\hat{g}, \phi] = \frac{-b}{32\pi^2} S_0[\hat{g}, \phi] + \frac{-a}{32\pi^2} S_1[\hat{g}, \phi] + \frac{a+b}{72\pi^2} S_{R^2} + \gamma' S_R + \lambda' S_{c.c.}, \quad (3.4)$$

where

$$\begin{aligned} S_0[\hat{g}, \phi] &= \int d^4x \sqrt{\hat{g}} \left[\frac{1}{2} \phi \hat{M} \phi + \left(\hat{G} - \frac{2}{3} \hat{\square} \hat{R} \right) \phi \right] \\ S_1[\hat{g}, \phi] &= \int d^4x \sqrt{\hat{g}} \hat{F} \phi \\ S_{c.c.} &= \int d^4x \sqrt{\hat{g}} e^{2\phi} \\ S_R &= \int d^4x \sqrt{\hat{g}} e^\phi \left[\hat{R} - \frac{3}{2} (\hat{\nabla} \phi)^2 - 3 \hat{\square} \phi \right] \\ S_{R^2} &= \int d^4x \sqrt{\hat{g}} \left[\hat{R} - \frac{3}{2} (\hat{\nabla} \phi)^2 - 3 \hat{\square} \phi \right]^2. \end{aligned} \quad (3.5)$$

b will turn out to be negative for ‘normal’ operators X . γ', λ' and $\frac{a+b}{72\pi^2}$ just renormalize γ, λ and η in (2.6). A ϕ -independent local term

$$- \int d^4x \sqrt{\hat{g}} \left(\frac{a+b}{72\pi^2} \hat{R}^2 + \gamma' \hat{R} + \lambda' \right) \quad (3.6)$$

has been omitted in (3.4) and will frequently be omitted in the following. If it is included, we see from (3.1) that for some action S_j :

$$S_i[\hat{g}, \phi] = S_j[\hat{g}e^\phi] - S_j[\hat{g}]. \quad (3.7)$$

$\frac{-b}{32\pi^2} S_0$ is the 4D analog of the 2D action

$$S_{2D} = \frac{c}{48\pi} \int d^4x \sqrt{\hat{g}} \left(\frac{1}{2} \phi \hat{\square} \phi - \hat{R} \phi \right).$$

If $\hat{g} = \tilde{g}e^{\phi_0}$ for any \tilde{g} , S_0 can be written:

$$S_0[\hat{g}, \phi] = \int d^4x \sqrt{\tilde{g}} \frac{1}{2} [(\phi + \phi_0) \tilde{M}(\phi + \phi_0) - \phi_0 \tilde{M} \phi_0]. \quad (3.8)$$

Adding up the anomaly coefficients in (3.2) for $(\det O^\dagger O)^{-\frac{1}{2}}$, $(\det L^\dagger L)^{+\frac{1}{2}}$, $(\det \Delta)^{-\frac{1}{2}}$,

$$A_0 \equiv a_O + a_L + a_{mat} \qquad B_0 \equiv b_O + b_L + b_{mat}, \quad (3.9)$$

(2.6) can now be rewritten as

$$\int \prod_i dm_i \chi(m_i) \int D\phi e^{\frac{B_0}{32\pi^2} S_0[\hat{g}, \phi] + \frac{A_0}{32\pi^2} S_1[\hat{g}, \phi] - \eta_1 S_{R^2} - \gamma_1 S_R - \lambda_1 S_{c.c.}} \quad (3.10)$$

$$\chi(m_i) \equiv (\det O^\dagger O)_{\hat{g}(m_i)}^{-\frac{1}{2}} (\det L^\dagger L)_{\hat{g}(m_i)}^{\frac{1}{2}} (\det \Delta)_{\hat{g}(m_i)}^{-\frac{1}{2}}$$

$\chi(m_i)$ is now purely a function of the moduli m_i , once we have fixed a representative $\hat{g}(m_i)$ for each point in moduli space.

The coefficients a and b in (3.2) are: [9,40,49,50]

	120 a	-360 b
conformally coupled scalars ($\Delta \sim \square - \frac{1}{6}R$):	1	1
spin $\frac{1}{2}$ (four component) fermions:	6	11
massless gauge fields:	12	62
$(\det O^\dagger O)^{-1/2} (\det L^\dagger L)^{1/2}$:	796	1566
$M \sim 2 \square^2 + \dots$ of (3.3):	-8	-28

(3.11)

Note that the fourth order derivative induced action makes the theory power counting renormalizable, and also bounded if $b < 0$. The price is the existence of a ghost, the general problem of fourth order derivative actions mentioned in the introduction. It has been suggested in [45], where the theory was studied in Minkowski space, that the reparametrization constraints $T_{\mu\nu} \sim 0$ eliminate these ghosts from the physical spectrum, as they do in two dimensions.^[7] This would be very interesting to verify.

4. DDK in 4D

Let us now focus on the ϕ integral over the conformal equivalence class of \hat{g} :

$$Z[\hat{g}] \equiv \int D_{\hat{g}e\phi} \phi e^{\frac{B_0}{32\pi^2} S_0[\hat{g}, \phi] + \frac{A_0}{32\pi^2} S_1[\hat{g}, \phi] - \eta_1 S_{R^2} - \gamma_1 S_R - \lambda_1 S_{c.c.}} \quad (4.1)$$

where the dependence of Z on η_1, γ_1 and λ_1 has been suppressed. In $D_{\hat{g}e\phi}$ it is indicated that the measure for ϕ depends on ϕ itself, namely in two ways: First, the

metric itself must be used to define a norm in the space of metrics:

$$\|\delta\phi\|^2 \equiv \int d^4x \sqrt{g} (\delta\phi(x))^2 = \int d^4x \sqrt{\hat{g}} e^{2\phi(x)} (\delta\phi(x))^2.$$

Second, in order to define a short distance cutoff one should also use the metric $\hat{g}e^\phi$ itself: the cutoff fluctuates with the field. Let us follow David, Distler and Kawai [4],[5] and assume that the ϕ dependence of the measure in (4.1) can be absorbed in a local renormalizable action:

$$D_{\hat{g}e^\phi} \phi e^{-S_i[\hat{g},\phi]} = D_{\hat{g}} \phi e^{-S_{loc}[\hat{g},\phi]}, \quad (4.2)$$

where now on the right-hand side

$$\|\delta\phi\|^2 \equiv \int d^4x \sqrt{\hat{g}} (\delta\phi(x))^2$$

and the cutoff no longer fluctuates.

What is S_{loc} ? Although the ϕ dependence of the measure in (4.1) looks inconvenient, we do learn something important from (4.1): simultaneously changing

$$\hat{g}_{\mu\nu} \rightarrow \hat{g}_{\mu\nu} e^{\phi_0}, \quad \phi \rightarrow \phi - \phi_0$$

does not change the measure or $S_{R^2}, S_R, S_{c.c.}$. It does change the induced action. From (3.7) we see (reinstating the ϕ independent terms (3.6) into (4.1)):

$$S_i[\hat{g}, \phi] \rightarrow S_i[\hat{g}, \phi] - S_i[\hat{g}, \phi_0].$$

We conclude that

$$Z[\hat{g}e^{\phi_0}] = Z[\hat{g}] e^{S_i[\hat{g}, \phi_0]} \quad (4.3)$$

and the ϕ theory behaves as if it were a conformal field theory with conformal anomaly (3.2) given by $a = -A_0$, $b = -B_0$. This is, of course, precisely what is needed in order

to insure that the background metric is really a fake: if we vary it, $\hat{g}_{\mu\nu} \rightarrow \hat{g}_{\mu\nu} e^{\phi_0}$, the variation of the determinants in (3.10) is determined by their total conformal anomalies $+A_0$, $+B_0$, defined in (3.9), and that just cancels the $-A_0$, $-B_0$ from the ϕ theory.

So let us replace (4.1) as in (4.2) by a four-dimensional conformal field theory with conformal anomaly given by

$$a = -a_O - a_L - a_{mat}, \quad b = -b_O - b_L - b_{mat}. \quad (4.4)$$

I will propose – and justify in a moment – that, as in two dimensions, S_{loc} in (4.2) is again the induced action with modified coefficients A, B and modified interactions:

$$Z[\hat{g}] \sim \int D_{\hat{g}} \phi e^{\frac{B}{32\pi^2} S_0[\hat{g}, \phi] + \frac{A}{32\pi^2} S_1[\hat{g}, \phi] - \eta_2 \hat{S}_{R^2} - \gamma_2 \hat{S}_R - \lambda_2 \hat{S}_{c.c.}}, \quad (4.5)$$

where \hat{S}_{R^2} , \hat{S}_R , and $\hat{S}_{c.c.}$ are marginal operators of the free theory given by S_0 and S_1 and will be discussed below.

The free theory ($\eta_2, \gamma_2, \lambda_2 = 0$) of (4.5) has conformal anomaly

$$a = -A + a_M, \quad b = -B + b_M, \quad (4.6)$$

where M is the operator (3.3). This can be seen as follows: Setting $\hat{g}_{\mu\nu} = \tilde{g}_{\mu\nu} e^{\phi_0}$ we see from (3.8):

$$\begin{aligned} & \int D_{\hat{g}} \phi e^{\frac{B}{32\pi^2} S_0[\hat{g}, \phi] + \frac{A}{32\pi^2} S_1[\hat{g}, \phi]} \\ &= \int D_{\tilde{g}} \phi e^{\int d^4 x \sqrt{\tilde{g}} \left\{ \frac{B}{64\pi^2} [(\phi + \phi_0) \tilde{M}(\phi + \phi_0) - \phi_0 \tilde{M} \phi_0] + \frac{A}{32\pi^2} [\tilde{F}(\phi + \phi_0) - \tilde{F} \phi_0] \right\}} \\ &= e^{-\frac{B}{32\pi^2} S_0[\tilde{g}, \phi_0] - \frac{A}{32\pi^2} S_1[\tilde{g}, \phi_0]} \int D_{\tilde{g}} \phi e^{\int d^4 x (\sqrt{\tilde{g}} \frac{B}{64\pi^2} \phi \tilde{M} \phi + \frac{A}{32\pi^2} \tilde{F} \phi)} \end{aligned} \quad (4.7)$$

by shifting $\phi \rightarrow \phi + \phi_0$ and using the fact that $\sqrt{g}M$ and $\sqrt{g}F$ are conformally invariant. So $-A, -B$ are the “classical” contributions* to (4.6) and a_M, b_M are the

* Here and below I will call these contributions “anomalies,” although they actually arise from the fact that the action is classically not quite conformally invariant.

quantum contributions from M . Therefore we see from (4.4) that the ansatz (4.5) is consistent if

$$A = a_O + a_L + a_{mat} + a_M \qquad B = b_O + b_L + b_{mat} + b_M. \qquad (4.8)$$

How do we know that a_M, b_M do not depend on the moduli m_i ? The only local scale invariant quantity they could depend on is $\int d^4x \sqrt{\hat{g}} \hat{F}$, which is a topological invariant in the case of $W_+ = 0$.

Why does the free part of S_{loc} in (4.2) have to be of the form of the free part of the induced action S_i again? One can plausibly, though not rigorously, argue as follows: there are two ways to obtain the right effective action (4.3) via (4.2); (a) S_{loc} is classically conformally invariant and a, b come purely from the quantum anomaly or (b) the “classical” variation of S_{loc} is of the form of the induced action S_i . In case (a) a and b would be just numbers that will in general not cancel the anomalies as needed in (4.4) (multiplying S_{loc} by a factor would then not change the conformal anomaly). Only in case (b) there are parameters like A, B in a, b that can be adjusted to satisfy (4.4). But the only local free action whose “classical” variation is the induced action is the induced action itself.

Let us now turn to the operators \hat{S}_{R^2}, \hat{S}_R and $\hat{S}_{c.c.}$ in (4.5). The consistency conditions of invariance under rescaling of the background metric (in particular that the theory is at a renormalization group fixed point) mean that the integrands of \hat{S}_{R^2} , the “dressed” Hilbert-Einstein action \hat{S}_R , and the “dressed” cosmological constant $\hat{S}_{c.c.}$ must be locally scale invariant operators. Let us try the ansatz

$$\begin{aligned} \hat{S}_{c.c.} &= \int d^4x \sqrt{\hat{g}} e^{2\alpha\phi} \\ \hat{S}_R &= \int d^4x \sqrt{\hat{g}} e^{\beta\phi} (\hat{\nabla}\phi)^2 + \dots \\ \hat{S}_{R^2} &= \int d^4x \sqrt{\hat{g}} (\hat{\nabla}\phi)^4 + \dots \end{aligned} \qquad (4.9)$$

with α, β , and “...” determined so that the integrands of (4.9) are scaling operators of conformal dimension 4, to cancel the -4 from $\sqrt{\hat{g}}$. In the language of string theory,

they are vertex operators of our theory of noncritical three branes. All of them should be moduli deformations, if the background metric \hat{g} is really fictitious. So far I have verified this only for $\hat{S}_{c.c.}$. The “...” includes possible corrections of order $\eta_2, \gamma_2, \lambda_2$ that may be needed in order to keep the other operators marginal as we move away from $\eta_2, \gamma_2, \lambda_2 = 0$. Some calculations with \hat{S}_{R^2}, \hat{S}_R and $\hat{S}_{c.c.}$ can also be found in [45] (however $\alpha = \beta$ there).

To calculate the (classical plus anomalous) dimension of $e^{2\alpha\phi}$ with action (4.5) at $\eta_2, \gamma_2, \lambda_2 = 0$ one may go to conformally flat $\hat{g}_{\mu\nu} = e^{\phi_0} \delta_{\mu\nu}$ where $\hat{M} = 2 \hat{\square}^2$ and $S_1 = 0$. Because of the shift $\phi + \phi_0 \rightarrow \phi$ in (4.7), the condition

$$\dim(e^{2\alpha\phi}) = 4 \quad \text{with action} \sim S_0 \quad (\text{given in (3.5)})$$

is equivalent to the condition

$$\dim(e^{2\alpha\phi}) = 4 - 4\alpha \quad \text{with action} \sim \int d^4x \phi \square^2 \phi. \quad (4.10)$$

Due to the quartic propagator, this four-dimensional theory is formally very similar to an ordinary free scalar field theory in two dimensions. In particular, $: e^{2\alpha\phi} :$ will be a scaling operator. Its dimension in (4.10) is now purely anomalous. It is found from the two-point function

$$\langle e^{2\alpha\phi(x)} e^{-2\alpha\phi(y)} \rangle \sim e^{-4\alpha^2 \Delta(|x-y|)} \sim |x-y|^{-\frac{8\alpha^2}{B}}, \quad (4.11)$$

where the propagator

$$\Delta(r) = \frac{2}{B} \log r \quad \text{with} \quad -\frac{B}{16\pi^2} \square^2 \Delta(r) = \delta(r)$$

of the free theory has been used. Thus, $\dim(e^{2\alpha\phi}) = \frac{4\alpha^2}{B}$, and (4.10) becomes:

$$4 - 4\alpha = \frac{4\alpha^2}{B}. \quad (4.12)$$

This determines α once B is known. See section 5 for the numerical discussion. Similarly, β in $\hat{S}_R = \int \sqrt{\hat{g}} e^{\beta\phi} (\hat{\nabla}\phi)^2 + \dots$ is determined by requiring $e^{\beta\phi}$ to have

dimension 2:

$$2 - 2\beta = \frac{\beta^2}{B}. \quad (4.13)$$

α and β are independent of the moduli m_i , for the same reason that a_M, b_M are.

The result for the dimension of the operator $e^{p\phi}$ agrees with the result of ref. [45] (Q^2 of [45] is $-2B$). Let me note two points of disagreement with ref. [45].

First, in [45] the theory of the conformal factor was studied as a ‘minisuperspace’ theory, rather than as gravity with a self-duality constraint. Further, it was suggested that this was the relevant description of gravity in the IR. But we will note below, following ref. [40], that the theory is a UV-, not an IR-fixed point of Weyl gravity. This justifies the use of the minisuperspace approximation in the UV, but not in the IR.

Second, we have found independent values of α and β in (4.9). In ref. [45] it was assumed that α had to be equal to β , with the conclusion that the operators \hat{S}_R and $\hat{S}_{c.c.}$ could not both be present at the fixed point. This led to a suggestion about the cosmological constant problem, and it implies different critical coefficients and a different value of the analog of the ‘ $c = 1$ barrier’ of two-dimensional gravity.

As in two dimensions, if Φ_i is a scaling operator of the matter theory with conformal dimension Δ_i , the operator

$$O_i \equiv \int d^4x \sqrt{\hat{g}} e^{\gamma_i \phi} \Phi_i$$

with γ_i determined analogously to (4.12) by

$$4 - 2\gamma_i = \frac{\gamma_i^2}{B} + \Delta_i \quad (4.14)$$

is a marginal operator that can be added to the action, at least infinitesimally.

Provided that truly marginal operators \hat{S}_{R^2}, \hat{S}_R can also be found, we can now

rewrite (3.10) as

$$\int \prod_i dm_i (\det O^\dagger O)^{-\frac{1}{2}} (\det L^\dagger L)^{\frac{1}{2}} \int D_{\hat{g}} x D_{\hat{g}} \phi e^{-S_{mat}[\hat{g}, x] - S[\hat{g}, \phi]},$$

$$S[\hat{g}, \phi] = \frac{-B}{32\pi^2} S_0[\hat{g}, \phi] + \frac{-A}{32\pi^2} S_1[\hat{g}, \phi]$$

$$+ \eta \hat{S}_{R^2}[\hat{g}, \phi] + \gamma \hat{S}_R[\hat{g}, \phi] + \lambda \hat{S}_{c.c.}[\hat{g}, \phi]. \quad (4.15)$$

The subscripts on η, γ, λ have been dropped. (4.15) describes free fields plus marginal interactions in a gravitational instanton background. A, B are given by (4.8) and (3.11) and $S_0, S_1, \hat{S}_{R^2}, \hat{S}_R, \hat{S}_{c.c.}$ by (3.5), (4.9), (4.12) and (4.13).

5. Results*

We can now make some numerical predictions: From (3.11) and (4.8),

$$A = \frac{1}{120}(N_0 + 6N_{\frac{1}{2}} + 12N_1 + 788), \quad B = -\frac{1}{360}(N_0 + 11N_{\frac{1}{2}} + 62N_1 + 1538) \quad (5.1)$$

where $N_0, N_{\frac{1}{2}}, N_1$ are the number of conformally coupled scalars, spin $\frac{1}{2}$ fermions and massless gauge fields. (4.12), (4.13) and (4.14) become

$$2\alpha = -B - \sqrt{B^2 + 4B},$$

$$\beta = -B - \sqrt{B^2 + 2B}, \quad (5.2)$$

$$\gamma_i = -B - \sqrt{B^2 + (4 - \Delta_i)B}.$$

Thus α will be real if $B \geq 0$ or $B \leq -4$. The second constraint is the relevant one since B is negative. The reality constraint $B \leq \Delta_i - 4$ on γ_i is weaker than the one for α in (5.2) as long as we allow only operators with positive dimension Δ_i . The signs in front of the square roots have been picked to give the correct results $\alpha = \beta = 1, \gamma_i = 2 - \frac{\Delta_i}{2}$ in the classical limit $B \rightarrow -\infty$.

* The earlier version of this work did not contain numerical results since I did not know the conformal anomaly coefficients of the O-L-determinant (fourth line in (3.11)). After it appeared it was pointed out in reference [50] that they had been computed in [40] and they were independently confirmed. Subsequently part of this section was added.

To compare with two dimensional gravity, define the anomaly coefficient $\tilde{c} \equiv -360 b$ as in (3.11). $B \leq -4$ becomes

$$\tilde{c}_{mat} + \tilde{c}_L + \tilde{c}_O + \tilde{c}_M \geq 1440 \rightarrow \tilde{c}_{mat} \geq -98. \quad (5.3)$$

The analogous restriction in two dimensions is $c_{mat} \leq 1$, where c_{mat} is the matter central charge. If the cosmological constant term is absent, the barrier for \tilde{c} , rather than being -98 , is determined by the lowest dimension operator. We see that in pure gravity α is real. In contrast with two dimensions, the situation is improved by adding conventional matter like conformally coupled scalar fields, families of fermions or gauge fields. The $\tilde{c} = -98$ barrier would only be crossed by adding exotic matter with positive anomaly coefficient b in (3.2).

Let us now derive scaling laws by studying the integral over the constant mode of ϕ , as is done in two dimensions.^[5,18] The fixed volume partition function at the critical point $\eta, \gamma, \lambda \sim 0$ is defined as

$$Z(V) \equiv \int \prod_i dm_i \chi(m_i) \int D_{\hat{g}} \phi e^{\frac{B}{32\pi^2} S_0[\hat{g}, \phi] + \frac{A}{32\pi^2} S_1[\hat{g}, \phi]} \delta\left(\int \sqrt{\hat{g}} e^{2\alpha\phi} - V\right) \quad (5.4)$$

with $\chi(m_i)$ as in (3.10). Under the constant shift $\phi \rightarrow \phi + c$ we see from (3.5):

$$\begin{aligned} \delta S_0 &= c \int d^4x \sqrt{\hat{g}} \hat{G}' = 32\pi^2 c \chi \\ \delta S_1 &= c \int d^4x \sqrt{\hat{g}} \hat{F}' = -48\pi^2 c \tau, \end{aligned} \quad (5.5)$$

where the topological invariants χ and τ are the Euler characteristic and signature of the manifold ($W_+ = 0$ here):^[51,9]

$$\tau = \frac{1}{48\pi^2} \int d^4x \sqrt{g} (W_+^2 - W_-^2) \quad \text{and} \quad \chi = \frac{1}{32\pi^2} \int d^4x \sqrt{g} G.$$

From this it follows that

$$\begin{aligned} Z(V) &= e^{(-2\alpha + B\chi - \frac{3}{2}A\tau)c} Z(e^{-2\alpha c} V) \\ \rightarrow Z(V) &\sim V^{-1 + \frac{1}{4\alpha}(2B\chi - 3A\tau)}. \end{aligned} \quad (5.6)$$

E.g., for the four sphere ($\chi = 2, \tau = 0$),

$$Z(V) \sim V^{-1+\frac{B}{\alpha}}. \quad (5.7)$$

α is given in terms of B by (4.12).

Inserting operators into (5.4) yields

$$\langle O_1 \dots O_n \rangle (V) \sim V^{-1+\frac{1}{4\alpha}(2B\chi-3A\tau+2\sum\gamma_i)}$$

with γ_i determined by (4.14). For nonzero cosmological constant λ one finds from

$$\langle O_1 \dots O_n \rangle_\lambda = \int dV e^{-\lambda V} \langle O_1 \dots O_n \rangle_0 (V) \quad (5.8)$$

the scaling behavior

$$\langle O_1 \dots O_n \rangle_\lambda \sim \lambda^{-\frac{1}{4\alpha}(2B\chi-3A\tau+2\sum\gamma_i)}, \quad (5.9)$$

provided the integral (5.8) converges, i.e. $\frac{1}{4\alpha}(2B\chi-3A\tau+2\sum\gamma_i) > 0$. Otherwise there will be additional cutoff-dependent terms in (5.9). ^[18]

Replacing in (5.4)

$$\delta\left(\int \sqrt{\hat{g}} e^{2\alpha\phi} - V\right) \rightarrow \delta\left(\frac{\int \sqrt{\hat{g}} e^{\beta\phi} [(\nabla\phi)^2 + \dots]}{\int \sqrt{\hat{g}} e^{2\alpha\phi}} - \bar{R}\right)$$

one obtains the partition function for fixed curvature per volume at $\eta, \gamma, \lambda = 0$:

$$Z(\bar{R}) \sim \bar{R}^{-1+\frac{B\chi}{\beta-2\alpha}-\frac{3}{2}\frac{A\tau}{\beta-2\alpha}}. \quad (5.10)$$

Scaling laws (5.6), (5.8) and (5.9) are similar to the two-dimensional ones, formulas (4.2), (4.3) and (4.4) of part I. A, B play the role of Q and the operators O_i were called \hat{V}_i in part I. Using the values (5.1), we conclude that for conventional matter,

on the sphere and at the critical point, $Z(V)$ always diverges (faster than V^{-1}) at small volumes and $Z(\bar{R})$ at large curvature per volume. E.g, for pure gravity on the sphere, (5.1), (5.2), (5.7) and (5.10) lead to the predictions:

$$Z(V) \sim V^{-3.675..} \quad Z(\bar{R}) \sim \bar{R}^{+3.194..} \quad (5.11)$$

These quantities should be the easiest ones to check with computer simulations.

6. Weyl Gravity at Short Distances

6.1. Fixed Points Of Gravity With A Weyl Term

It was claimed in the introduction that conformally self-dual gravity can also be understood as quantum gravity with the action

$$\int_M d^4x \sqrt{g} (\lambda + \gamma R + \eta R^2 + \rho W_+^2) \quad (6.1)$$

in the limit

$$\rho \rightarrow \infty. \quad (6.2)$$

Here, $\int W^2$ in (1.1) has been replaced by $\int W_+^2$. They differ only by the topological invariant τ of the previous section.

In section 2, the metric was split into ϕ , diffeomorphisms ξ , moduli m_i and five \bar{h} components. (6.2) can be understood as the “classical limit” for the \bar{h} components, in which only the linearized W_+ term $O^\dagger \bar{h}$ of (2.5) is important for the \bar{h} integral. This Gaussian integral can be performed at each point $g_0(\phi, \xi, m_i)$,

$$\int D\bar{h} e^{-\rho \int d^4x \sqrt{g} W_+^2} \sim (\det \rho O O^\dagger)_{g_0}^{-\frac{1}{2}} = (\det \rho O^\dagger O)_{\hat{g}e\phi}^{-\frac{1}{2}}.$$

This leads again to the integral (2.6), our starting point, so the two theories are equivalent. (The extra factor ρ only renormalizes the cosmological constant and does not influence the anomaly coefficients of section 3.)

As pointed out in the introduction, the R^2 and W_+^2 terms would give rise to negative norm states in Minkowski space. Note however that this need not necessarily bother us in the limit $\rho \rightarrow \infty$, because then the W_+^2 term decouples and we can fine-tune away the R^2 term in the end. In any case, there is no unitarity problem in Euclidean space.

One might worry that the renormalization group flow will take us from $\rho \sim \infty$ to finite ρ so that the limit (6.2) does not make sense as an effective theory. However, since at $\rho \sim \infty$ the five \bar{h} components decouple from the other five components of the metric, $\rho \sim \infty$ corresponds to a renormalization group fixed point. More precisely, defining $\epsilon \equiv \frac{1}{\sqrt{\rho}}$, rescaling $\bar{h} \rightarrow \epsilon \bar{h}$ and expanding the action in ϵ , one obtains:

$$L_0[\phi, x] + \bar{h}OO^\dagger\bar{h} + \epsilon L_i[\bar{h}, \phi, x] + O(\epsilon^2) \quad (6.3)$$

where L_0 is the \bar{h} -independent part, and L_i are interaction terms of \bar{h} with itself, ϕ and x , x representing matter fields that might be present. Thus the beta function for $\epsilon \sim \rho^{-\frac{1}{2}}$ will receive contributions only from diagrams that couple \bar{h} and ϕ , so it will be at least of order ϵ and vanish as $\epsilon \rightarrow 0$. If $(\bar{\lambda}, \bar{\gamma}, \bar{\eta})$ is a fixed point of L_0 , then $(\bar{\lambda}, \bar{\gamma}, \bar{\eta}, \rho = \infty)$ will be a fixed point of (6.1).

It has been pointed out in ref. [40], that for $\lambda = \gamma = \eta = 0$, $\rho = \infty$ is an ultraviolet fixed point. Since the cosmological constant and the Hilbert–Einstein action are relevant operators, this fixed point is UV–stable in the λ and γ directions, but I presently do not know whether it is stable in the η direction. If so, conformally self–dual gravity can be viewed a short–distance phase of Euclidean gravity. Of course, in this case “short distance” means “distance much shorter than the Planck length,” a notion that might be meaningless in the real world (but not in statistical mechanics).

Hopefully the results found in section 5 will be the starting point for finding similar results for ρ finite or zero, by means of an expansion in $1/\rho$. It would be very interesting to investigate if the barrier in (5.3) then becomes positive.

6.2. Topological Gravity

In two-dimensional quantum gravity the correlation functions of local operators are related to the correlation functions of topological gravity^[47] which are intersection numbers of submanifolds on the moduli space of Riemann surfaces with punctures. Given the similarity of conformally self-dual quantum gravity to two-dimensional quantum gravity, it would be very interesting to see if there is a similar relation between it and four-dimensional topological gravity.^[23]

This is suggested by the fact that the moduli space of the latter theory seems to be precisely the moduli space of conformally self-dual metrics that arose here. One might be able to find a matter system, analogous to the $c = -2$ system in two dimensions^[22] that, coupled to gravity, reproduces the BRST multiplet of 4D topological gravity. In this sense, Euclidean quantum geometry might have a topological description at short distances.

Conclusion of Part III

Surprisingly enough, methods of two-dimensional quantum gravity can be applied to four-dimensional quantum gravity at least in the limit of infinite Weyl coupling. The scaling predictions (5.11) can hopefully be compared with numerical simulations based on random triangulations. It will be interesting to investigate how the $\tilde{c} = -98$ barrier moves, as ρ in (6.1) moves away from ∞ .

Many other interesting questions could now be asked, but this will be left for future work.

REFERENCES

1. V. Kazakov, Phys. Lett. 150B, 282 (1985); F. David, Nucl. Phys. B257, 45 (1985)
2. A.M. Polyakov, "Gauge Fields and Strings," Harwood Academic Publishers 1987
3. A.M. Polyakov, Phys. Lett. 103B, 207 (1981)
4. F. David, Mod. Phys. Lett. A3, 1651 (1988)
5. J. Distler and H. Kawai, Nucl. Phys. B321, 509 (1988)
6. J. Polchinski, Nucl. Phys. B346, 253 (1990)
7. E.g., M.B. Green, J.H. Schwarz and E. Witten, "Superstring Theory," Cambridge University Press 1987
8. L. Alvarez-Gaumé and E. Witten, Nucl. Phys. B234, 269 (1983)
9. E.g., N. D. Birrell and P. C. W. Davies, "Quantum Fields in Curved Space," Cambridge University Press 1982
10. A.A. Belavin, A.M. Polyakov and A.B. Zamolodchikov, Nucl. Phys. B241 (1984)
11. D. Friedan, in Proceedings of the Les Houches session XXXIX, "Recent Advances in Field Theory and Statistical Mechanics." (1982)
12. V. Knizhnik, A. M. Polyakov and A. B. Zamolodchikov, Mod. Phys. Lett. A3, 819 (1988)
13. E.g., J. H. Cardy, Les Houches session XLIX, 1988
14. J.L. Gervais and A. Neveu, Nucl. Phys. B199, 59 (1982); B209, 125 (1982); B238, 125; 396 (1984); Phys. Lett. 151B, 271 (1985)
15. A. Gupta, S. Trivedi and M.B. Wise, Nucl. Phys. B340, 475 (1990)
16. M. Goulian and M. Li, Phys. Rev. Lett. 66, 2051 (1991)

17. E.g., D. J. Gross and A. A. Migdal, Nucl. Phys. B340, 333 (1990) and references therein.
18. N. Seiberg, Prog. Theor. Phys. S102, 319 (1990)
19. J. Distler, Z. Hlousek and H. Kawai, Int. J. of Mod. Phys. A5, 1093 (1990)
20. J. Polchinski, talk given at strings '90, Coll. Station, Texas; publ. in Coll. Station Wkshp. 1990, 62 (1990)
21. G. Moore, N. Seiberg and M. Staudacher, Nucl. Phys. B362, 665 (1991)
22. J. Distler, Nucl. Phys. B342, 523 (1990)
23. E. Witten, Phys. Lett. 206B, 601 (1988); J.M.F. Labastida and M. Pernici, Phys. Lett. 212B, 56 (1988)
24. E. Witten, Nucl. Phys. B373, 187 (1991)
25. I. Klebanov and A. M. Polyakov, Mod. Phys. Lett. A6, 3273 (1991)
26. I. Klebanov, Lectures at ICTP Spring School, Trieste (1991)
27. E. Brézin, C. Itzykson, G. Parisi and J.B. Zuber, Comm. Math. Phys. 59, 35 (1978)
28. C. Itzykson and J.B. Zuber, J. Math. Phys. 21(3), 411 (1980)
29. V. Kazakov and A. Migdal, Nucl. Phys. B311, 171 (1989)
30. M. Douglas and S. Shenker, Nucl. Phys. B335, 635 (1990); E. Brézin and V. Kazakov, Phys. Lett. 236B, 144 (1990); D.J. Gross and A.A. Migdal, Phys. Rev. Lett 64, 717 (1990)
31. G. Moore, Yale preprint YCTP-P1-92
32. V.A. Kazakov, Phys. Lett. 119A, 140 (1986)
33. A. M. Polyakov, Mod. Phys. Lett. A6, 3273 (1991)
34. G. Segal, Comm. Math. Phys. 80, 301 (1981)
35. A. Cooper, L. Susskind and L. Thorlacius, Nucl. Phys. B363, 132 (1991)

36. D. Kutasov, Princeton preprint PUPT-1334 (1992)
37. A. M. Polyakov, Lectures in Les Houches, July 1992
38. D. Gross and I. Klebanov, Nucl. Phys. B344, 475 (1990)
39. J. H. Schwarz, Phys. Lett. 272B, 239 (1991)
40. E.S. Fradkin and A.A. Tseytlin, Nucl. Phys. B201, 469 (1982)
41. C. Schmidhuber, Nucl. Phys. B390, 188 (1993)
42. A.A. Tseytlin, Phys. Lett. B264, 311 (1991)
43. T. Banks, Nucl. Phys. B361, 166 (1991)
44. M. E. Agishtein and A. A. Migdal, Nucl. Phys. B350, 690 (1991)
45. I. Antoniadis and E. Mottola, Los Alamos preprint LA-UR-91-1653 (1991)
46. E. D' Hoker, Mod. Phys. Lett. A6, 745 (1991)
47. E. Witten, Nucl. Phys. B340, 281 (1990); E. and H. Verlinde, Nucl. Phys. B348, 457 (1991)
48. In T. Eguchi, P. B. Gilkey and A. J. Hanson, Phys. Rep. 66, 213 (1988), after I. M. Singer
49. A.O. Barvinsky and G.A. Vilkovisky, Phys. Rep. 119, 1 (1985)
50. I. Antoniadis, P.O. Mazur and E. Mottola, preprint CPTH-A173.0492 / LA-UR-92-1483 (1992)
51. E.g., M.F. Atiyah, N.J. Hitchin and I.M. Singer, Proc. Roy. Soc. London A362, 425 (1978)