

ACTIVATION OF MOLECULAR HYDROGEN BY ELECTRON IMPACT
VELOCITY DISTRIBUTION OF ELECTRONS ISSUING FROM SMALL HOLES
ACTIVATION OF GASES BY ELECTRON IMPACT

Thesis by
Robert H. Dalton

In partial fulfillment of the requirements
for the degree of Doctor of Philosophy

California Institute of Technology
Pasadena, California

1928

[Reprint from the Journal of the American Chemical Society, 49, 58 (1927).]

[CONTRIBUTION FROM THE GATES CHEMICAL LABORATORY, CALIFORNIA INSTITUTE OF TECHNOLOGY, No. 114]

THE ACTIVATION OF MOLECULAR HYDROGEN BY ELECTRON IMPACT

BY GEORGE GLOCKLER, WARREN P. BAXTER AND ROBERT H. DALTON

RECEIVED SEPTEMBER 30, 1926

PUBLISHED JANUARY 11, 1927

Introduction

In this research we have undertaken to study the activation of hydrogen molecules by electron impact under conditions in which we know the energies of the impinging electrons. The experiments of Cario and Franck¹ show that hydrogen molecules can be activated by excited mercury atoms by collisions of the second kind and that copper oxide and tungstic oxide can then be reduced. In their experiments the mercury atoms receive energy of 4.9 volts from the light source, which is sufficient to dissociate hydrogen molecules, the heat of dissociation of hydrogen being 3 to 4 volts. Furthermore, it has been known for some time that in a discharge tube hydrogen will disappear when a discharge is passed.² Hughes,³ in particular, has investigated the electrical clean-up of hydrogen and nitrogen, and finds a definite decrease in the hydrogen pressure at 13.3 volts and higher. He adopts Langmuir's conclusion⁴ that hydrogen is dissociated under these conditions, and that the decrease in pressure is due to the freezing out of atomic hydrogen on surfaces cooled by liquid air. His results will be referred to later in connection with our own experiments. In Hughes' investigations no copper oxide was present, and the minimum electron energy at which hydrogen disappears was not accurately determined. A number of experimenters⁵ also have investigated the chemical reactivity of hydrogen activated by an electric discharge, but the energies of the impinging electrons were not known.

We shall discuss four possible mechanisms by which electrons may be expected to activate hydrogen molecules.

First, it might be that an electron having kinetic energy of 3 to 4 volts could transfer its energy to the hydrogen molecule and cause its dissociation into atoms. These in turn could then react with other substances. However, it is known that no kink occurs in current-potential curves of hydrogen near 4 volts, and it seems, therefore, that electrons having kinetic energy equal to the dissociation energy of hydrogen molecules

¹ Cario and Franck, *Z. Physik*, **11**, 161 (1922).

² An excellent discussion of these phenomena may be found in Dushman "High Vacuum," *Gen. Electric Rev.*, 1922.

³ Hughes, *Phil. Mag.*, **41**, 778 (1921).

⁴ Langmuir, *THIS JOURNAL*, **34**, 1310 (1912); **37**, 417 (1915).

⁵ Wendt and Landauer, *ibid.*, **42**, 930 (1920); **44**, 510 (1922). Bonhoeffer, *Z. physik. Chem.*, **113**, 199 (1924); and others.

cannot transfer their energy to these molecules. We then should expect to find no evidence of reaction when hydrogen is bombarded with 4-volt electrons, and our experiments actually do give no indication of reaction. This is in agreement with the commonly held idea that the dissociation of molecules does not occur as the direct result of electron impact.

Second, electrons may have to possess sufficient energy to resonate the molecule, which may then dissociate if its heat of dissociation is less than its resonance potential. The hydrogen molecule has, according to the latest results of spectroscopy,⁶ a resonance potential at 11.6 volts. Electrons of this energy can raise hydrogen molecules into an upper quantum state. These activated molecules would ordinarily return to the normal state after a short time. However, they may either dissociate into atoms upon impact with other molecules and the atoms thus react, or the resonated molecules may act directly on any oxide or other substance on which they impinge.

A third mechanism of causing activation by electron impact might be that where the impinging electron transfers enough energy to the hydrogen molecule to cause its dissociation and resonance of one of the atoms. This process may be expected at 13 to 14 volts, which is the sum of the heat of dissociation and the resonance potential of the hydrogen atom. This is the mechanism postulated by Hughes.³

A fourth possibility may be considered. It may be necessary that an electron ionize a hydrogen molecule before the latter can be made to react. It was found by Anderson⁷ and Storch and Olson⁸ that nitrogen and hydrogen reacted to form ammonia when bombarded by 17-volt electrons. This voltage is near the ionization potentials of these molecules.

We may state at once the results of our experiments. *Electrons of 11.4 volts' energy can activate hydrogen molecules*, for we find that there is a definite pressure decrease when the accelerating voltage applied to our tube has this value. At the same voltage we also obtain a kink in the current-potential curves, using the Franck method.

This research was aided financially by a grant made to Professor A. A. Noyes by the Carnegie Institution of Washington.

Experimental Procedure

The experimental arrangement is shown in Fig. 1.

The filament *F* was made of platinum foil coated with calcium oxide. This was surrounded with a platinum can having in the end a circular grid *G*₁, 0.5 cm. in diameter made from platinum gauze of 52 mesh. The next electrode consisted of a copper cylinder *B*, 4.5 cm. in diameter with a platinum grid *G*₂, also of 52 mesh at the end. One millimeter behind this second grid was a platinum plate *P*. The distance between the

⁶ Witmer, *Proc. Nat. Acad. Sci.*, **12**, 238 (1926).

⁷ Anderson, *Z. Physik*, **10**, 54 (1922).

⁸ Storch and Olson, *THIS JOURNAL*, **45**, 1605 (1923).

filament and first grid was 1 mm., and between the two grids 4 cm. A copper cooling coil *C*, through which tap water could be circulated, was introduced into the tube by means of copper disk seals, and made good electrical and thermal contact with the copper cylinder. The copper cylinder and cooling coil were surface oxidized in a Bunsen flame before being placed in the tube, thus providing a large surface of copper oxide.

With the tube first used, which had no cooling coil, it was found that with the filament lighted, but with no accelerating field on, there was a noticeable rate of decrease of pressure. Since this effect may have been due to reduction by the hydrogen of the copper oxide heated by conduction from the hot filament, the cooling coil described above was introduced into the tube, with the result that there was no longer any decrease in pressure, but instead a smaller rate of pressure increase. This increasing pressure may possibly be due to slow evolution of gas from the heated filament or from the metal surfaces bombarded by electrons. It was too large to be accounted for by leaks, which were carefully tested for. These zero rates, however, caused no difficulty in determining the voltage at which reaction did begin.

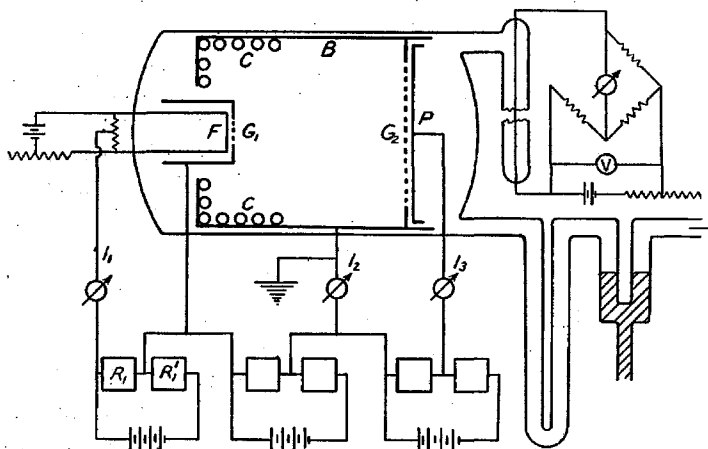

Fig. 1.—Experimental tube and wiring diagram.

The electrical connections are as shown. The total current, henceforth designated by I_1 , and the current to the second can, I_2 , were measured on the same galvanometer with a scale 1 meter long and 3 meters away. On the most sensitive shunt 8.16×10^{-9} amperes gave a deflection of 1 cm. Another galvanometer, giving a deflection of 1 cm. for 1.09×10^{-11} amperes on its most sensitive shunt, was used to measure the plate current I_4 . The voltage applied between the filament and grid G_1 was calculated from the equation

$$E_1 = \frac{R_1}{R_1 + R_2} [E - I_1 R_2]$$

E is the voltage across the potentiometer, and R_1 and R_2 are the respective readings of the two resistance boxes (the sum of whose resistances was kept at 10,000 ohms). The term $I_1 R_2$ is introduced because of the electron current flowing from the filament to the other electrodes, hence through R_2 and back to the filament, and is relatively important at the emissions used (0.1 to 1 milliamperes).

One side tube led to a liquid-air trap and mercury cut-off, thence to a palladium tube for admitting hydrogen, a McLeod gage, another mercury cut-off, and pumps. Another side tube led to a Pirani resistance gage which consisted of a thin tungsten wire

9 cm. long enclosed in a narrow glass tube. It was used according to the method described by Campbell,⁹ and shown in the figure. By putting the gage in one arm of a Wheatstone bridge, the other three resistances of which were fixed and each one-third greater than the Pirani resistance at room temperature, any change in pressure could be followed by means of the voltage necessary to obtain a balance. The voltage was calibrated against the McLeod gage for a series of pressures of hydrogen up to 0.3 mm. of mercury. The Pirani gage was shielded from drafts, but no attempt was made to thermostat it. In order to follow small pressure changes, a more sensitive galvanometer was thrown across the bridge after a balance had been obtained, and readings were made with a telescope and scale 80 cm. away. With this set-up 1 cm. change in the scale reading corresponded to approximately 4×10^{-5} mm. in a total pressure of hydrogen of 0.2 mm. The volume of the tube up to the mercury cut-off was about 320 cc.

It will be seen that with this apparatus the following objectives can be attained. (a) Electrons emitted from the heated filament can be accelerated to a known velocity by the first grid and activate hydrogen molecules, which may then react with the copper oxide. (b) The water formed can be frozen out in the liquid-air trap with a resulting decrease in pressure. (c) The rate of decrease of pressure can be followed by means of the Pirani gage. (d) Mercury vapor is frozen out by the liquid air; thus, resonated mercury atoms cannot excite hydrogen molecules and cause reaction. (e) Current-potential curves can be taken by either the Franck or Lenard methods in the usual manner.¹⁰

The procedure adopted was as follows. After pumping out to 10^{-5} mm., hydrogen was admitted by heating the palladium tube in a gas flame, and readings were taken on the McLeod gage and on the voltmeter of the Pirani gage after liquid air had been placed about the liquid-air trap. The filament was then lighted and its temperature adjusted to give the emission desired at a definite accelerating voltage. After conditions had become steady, the mercury cut-off was closed and a series of readings with no accelerating field was taken on the rate of deflection of the sensitive galvanometer in the Pirani set-up. These readings constituted a set of "zero rates" for that particular run. Then the electrons were accelerated with a definite potential, and a similar set of rate measurements was taken. From time to time the mercury cut-off was opened and closed, allowing the hydrogen to come up to its original pressure. The voltage was increased in steps of 0.4–0.5 v. This process was repeated until rates had been obtained covering the voltage range desired. At the same time readings were taken of the total current I_1 , and of I_2 and I_3 . No field was applied between the two grids, but a retarding potential of 0.5 v. was maintained between the second grid and plate. In these runs either the total current I_1 or the sum of the currents $I_2 + I_3$ was kept constant by adjusting the filament temperature.

⁹ Campbell, *Proc. Phys. Soc. London*, 33, 287 (1921).

¹⁰ These methods are fully described in "Critical Potentials," Compton and Mohler, *Bull. Nat. Res. Council*, 1924, and elsewhere.

Experimental Results

Reaction Measurements.—Careful investigation failed to give any evidence of reaction between 0 and 10 volts' accelerating potential. It was found, however, that reaction does begin around 11.4 volts. From 11.4 volts on, the rate of pressure decrease rises rapidly with the applied voltage until the ionization potential is just passed and the glow discharge sets in. Above ionization it was found in most of the runs that the rates increase only slowly with the voltage, but depend primarily on the number of electrons passing through the first grid.

Since electrons are not emitted from a heated platinum-calcium oxide surface until a certain accelerating voltage is applied, a corresponding correction must be applied to the voltage scale. This initial velocity correction was determined as follows. For a constant heating current, the accelerating voltage was increased in small steps from 0 to 5 v., and the total current I_1 read. The foot of the curve so obtained corresponds to the voltage at which the fastest electrons will just escape from the filament and gives the correction to be subtracted from the observed voltage at which reaction begins. Four determinations for different heating currents gave 1.12, 1.19, 1.20 and 1.21, average 1.2 v.

In Table I are given the voltages (from which the correction of 1.2 v. has been subtracted) at which reaction is found to begin. The average of these values is 11.4 v. The table contains all our experiments.

TABLE I
VOLTAGE (CORRECTED) AT WHICH REACTION STARTS

| Expt. | Pressure of H ₂ , mm. of Hg | Volts | Expt. | Pressure of H ₂ , mm. of Hg | Volts |
|-------|---|-------|-------|---|-------|
| 1 | 0.262 | 11.8 | 7 | 0.203 | 10.9 |
| 2 | .249 | 11.9 | 8 | .244 | 11.2 |
| 3 | .168 | 11.8 | 9 | .175 | 12.0 |
| 4 | .124 | 11.4 | 14 | .162 | 10.9 |
| 5 | .103 | 11.9 | 15 | .193 | 10.4 |
| 6 | .158 | 11.5 | 18 | .185 | 11.5 |

Resonance Potential of Hydrogen.—In order to determine the significance of the value 11.4 v., Franck current-potential curves were taken in hydrogen and in hydrogen-helium¹¹ mixtures of the composition 0.1 mm. of hydrogen and 1.1 mm. of helium. In making these runs, I_1 was kept constant and readings taken of I_3 . A retarding potential of 0.5 v. was applied between the plate and second grid, while the accelerating potential was increased in small steps. Prominent kinks occurred in the I_3 curves taken in pure hydrogen around 13.5 and 19 v. uncorrected. In the curves for the hydrogen-helium mixtures similar kinks were found,

¹¹ The helium used was that prepared previously. Glockler, *Phys. Rev.*, 27, 423 (1926).

as also a new one at 22 volts, due to the first resonance potential of helium. By plotting the differences of successive I_3 readings the kinks were brought out very strongly. The voltages at which the kinks occurred were obtained from the maxima in these difference curves, which give the point at which the rate of change of slope is the greatest, thus corresponding to the middle of the electron velocity distribution. Two determinations by the Franck method gave the helium kink at 21.88 and 21.75 v., and a Lenard run, 21.90. From spectroscopy the value of the resonance potential of helium is 19.77 v., which has also been obtained by the method of electron impact. Therefore, by subtracting 19.77 from the above values the initial velocity correction can be obtained. This comes out 2.11, 1.98 and 2.13, average 2.08 v. Table II summarizes the values found for the first kink in hydrogen after the correction of -2.08 v. has been applied.

It is seen that the two methods used to determine the initial velocity correction give identical results for the voltage at which reaction starts and for the resonance potential of hydrogen.

TABLE II

| Expt. No. | RESONANCE POTENTIAL OF HYDROGEN | | | | | | | |
|--------------------------------|---------------------------------|-------|-------|-------|-------|-------|------------------|------------------|
| | 10 | 11 | 12 | 13 | 14 | 15 | 16 | 17 |
| H ₂ pressure in mm. | 0.128 | 0.28 | 0.16 | 0.162 | 0.162 | 0.175 | 0.1 ^a | 0.1 ^a |
| Volts, corrected | 11.28 | 10.93 | 11.27 | 12.09 | 11.58 | 11.73 | 10.83 | 11.33 |
| Volts, averaged | 11.38 | | | | | | | |

^a Plus 1.1 mm. of He.

This experimental value of 11.4 v. agrees well with the value 11.6 derived by Witmer⁶ from spectroscopic data for the first resonance potential of the hydrogen molecule. It is also seen to coincide with the voltage at which hydrogen begins to disappear and we may therefore conclude that the first step in the reaction at these voltages is the formation of resonated hydrogen molecules by collision with 11.4 electrons. The resonated hydrogen molecule may then react directly with the copper oxide or be dissociated by collision with other molecules and subsequently react. Of course, after the first resonance potential is passed, the process of activation may include higher energy levels, and when ionization is reached the mechanism of reaction may be considerably altered. Further work on these points is to be continued; we wish only to record here the fact that reaction does set in when the first resonance potential of the hydrogen molecule is reached.

In order to identify still further the beginning of reaction with the resonance potential, several runs were made in which both rates and Franck current-potential curves were taken. Fig. 2 illustrates two of these runs. *In each case, it was observed that the break in the Franck curve begins at the same point as that at which the hydrogen pressure starts to drop.*

Identification of the Reaction Product

In order to determine the nature of the final reaction product, one of the runs was continued until all of the hydrogen had reacted (pressure about 10^{-4} mm.). On removing the liquid air the pressure rapidly rose. After 30 minutes the liquid air was replaced. The pressure immediately fell to its original value. This is the opposite of the results of Hughes³ (in the absence of copper oxide) for he found that on removing the liquid air

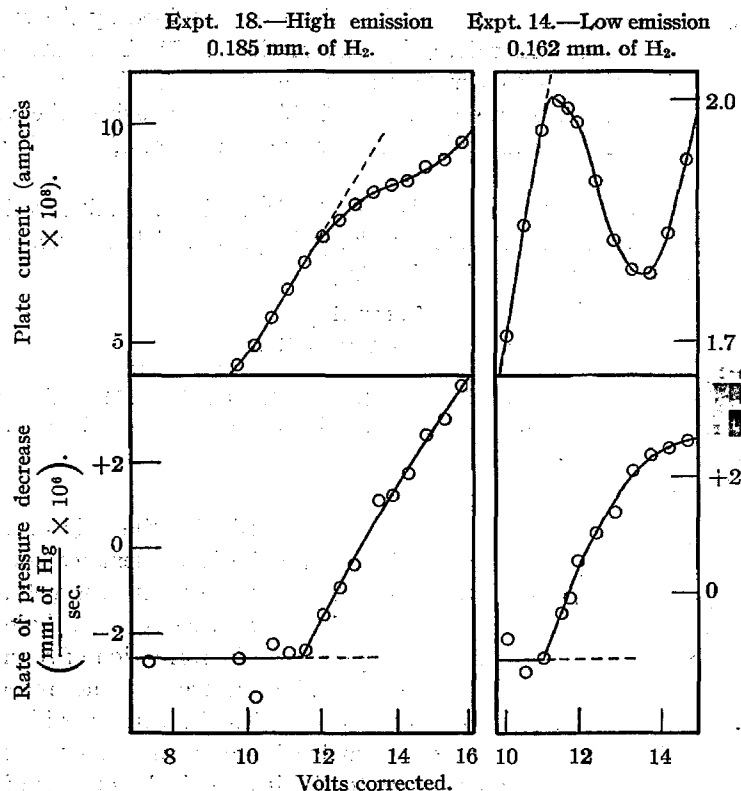

Fig. 2.—Two runs illustrating the relation between the beginning of the break in the Franck current-potential curve and the voltage at which reaction starts.

and replacing it the pressure did not fall to its original value due to the presence of a non-recondensable gas. The non-recondensable gas he assumes, with Langmuir,⁴ to be molecular hydrogen formed by the recombination of atomic hydrogen that had previously been frozen out on the walls at liquid-air temperature. To determine whether or not water was formed in our experiment the liquid air was again removed, the mercury cut-out opened, and the pressure read on the McLeod gage. The two

columns maintained a nearly constant difference of height except near the closed end of the capillary. After correcting for the small pressure of uncondensable gases, the difference of height was found to be 2.6 cm. The vapor pressure of water at the same temperature is 2.65 cm.

Summary

Hydrogen molecules have been activated by collisions with electrons of known energy and made to react with copper oxide. It is found that reaction begins at 11.4 volts. At the same time Franck current-potential curves show a resonance point at 11.4 volts. This agrees with the recent value of 11.6 volts for the first resonance potential of the hydrogen molecule as obtained from spectroscopy. It is concluded, therefore, that the first step in the activation process at low voltages is the formation of a resonated hydrogen molecule.

No evidence is found that 3- to 5-volt electrons dissociate hydrogen molecules.

PASADENA, CALIFORNIA

THE VELOCITY DISTRIBUTION OF ELECTRONS ISSUING FROM SMALL HOLES

BY ROBERT H. DALTON AND WARREN P. BAXTER

ABSTRACT

The velocity distribution of a beam of 50-volt electrons issuing from a hole 0.022 cm in diameter in a copper plate 0.02 cm thick has been measured. Seventy percent of the electrons were found to retain approximately their initial velocity. By coating the sides and edges of the hole with lampblack 95% of the electrons were transmitted without appreciable energy loss. Similar results were obtained with grids of 100 mesh copper gauze.

INTRODUCTION.—Preliminary to the construction of a magnetic electron velocity filter, some experiments were undertaken to determine the effect of passage through small holes or fine-mesh gauzes on the velocity distribution of an electron beam. Lehman and Osgood¹ found that with velocities of the primary beam corresponding to from 200 to 1000 volts less than 1% of the electrons passing through a hole 0.19 mm in diameter in a copper plate 0.135 mm thick retain their initial velocity. Since in similar experiments with 50-volt electrons we

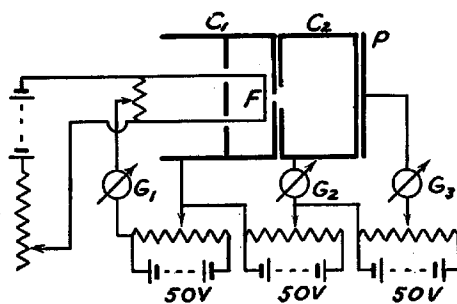

Fig. 1.

were able by using non-reflecting surfaces to get through more than 90% of the electrons with their initial velocity, it seems worth while to publish a brief description of our experiments.

Experimental arrangement. The apparatus is shown diagrammatically in Fig. 1. The source of electrons is a platinum filament F coated with calcium oxide operating on a potential-drop of 2 volts. Surrounding this is the cylindrical copper cage C_1 , pierced by a hole 0.022 cm in diameter at a point opposite the center of the filament. The copper in

¹ Lehman and Osgood, Proc. Cambridge Phil. Soc. 22, 731 (1925).

the neighborhood of the hole is 0.02 cm thick, and the distance to the filament is about 0.1 cm. C_2 is a similar cage 2 cm long with a hole 0.5 cm in diameter in the end facing C_1 . The ends of the cages are discs which screw into place so that they may readily be replaced by grids, in which case the copper plate P is used to measure the current traversing the second of these. It is about 0.1 cm from C_2 . All the cages have an inner diameter of 3 cm. The cages, plate, and filament are mounted rigidly with respect to one another and are suspended with the axis of the cylinders parallel to the earth's magnetic field in a tube closed by a ground-glass stopper (set in sealing wax) and connected with a liquid-air trap, a McLeod gauge, and vacuum pumps. G_1 , G_2 , and G_3 are galvanometers measuring the total current, the current from C_2 , and the plate current, respectively.

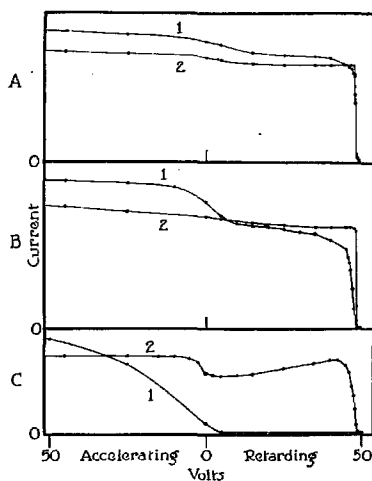

Fig. 2.

The general procedure was as follows. The apparatus was pumped out to a pressure of 10^{-4} to 10^{-5} mm, and the pumps were kept running during all the measurements. An accelerating potential of 50 volts was established between C_1 and the filament, and the temperature of the latter adjusted till a convenient emission resulted. The current through G_2 was then measured with various retarding potentials between C_1 and C_2 . When the end of C_2 was replaced by a grid, the plate-current was read on G_3 with various retarding potentials between C_2 and the plate.

Experimental results. The experimental curves are reproduced in Fig. 2. Curve A(1) was obtained with the hole 0.022 cm in diameter. The metal parts were baked out in vacuum at about 400° before

placing in the apparatus, but no attempt was made to reduce the surface layer of copper oxide. The current to cage C_2 is plotted against the retarding or accelerating potential between C_1 and C_2 . It is apparent from the curve that about 70% of the electrons (based on the current at zero volts) retain nearly their original velocity. To determine whether low velocity reflection and secondary emission were affecting the distribution, the end of C_1 was now coated with lampblack in a candle flame, since Gehrts² has shown that a lampblack surface is a good absorber for electrons. Curve $A(2)$ shows the result obtained using the same total emission as for curve $A(1)$. About 95% of the electrons have their initial velocity. It is also interesting to note that the actual number of electrons retaining their initial velocity is nearly the same in the two cases, so apparently the only action of the soot is to remove from the beam all those electrons which strike even a glancing blow, thus preventing reflection and secondary emission, and eliminating the low-energy group previously present. Another distribution curve was taken after sooting C_1 and C_2 completely; but the curve was practically the same as $A(2)$, showing that C_2 was an efficient Faraday cage.

These are much better distributions than were obtained by Lehman and Osgood in the experiments above cited. The difference may be due to the higher voltage at which they worked, since it is known that the reflection of electrons from copper increases with the voltage up to 200–300 volts. The nature of the surface as determined by the previous treatment of the copper would also affect the reflection. In some earlier experiments where a crude apparatus was used, in which the metal parts were not baked out, we obtained curves somewhat similar to theirs, but after sooting the copper surfaces the results were as good as with the apparatus described above.

Since, in most of the experiments in electron impact work, the electrons traverse wire gauze grids, an experiment was tried to determine the effect of lampblack under these conditions. The hole in C_1 was replaced by a circular grid of 100 mesh copper gauze 0.5 cm in diameter, while the end of C_2 opposite the plate was replaced by a similar grid 2.5 cm in diameter. Curve $B(1)$ is a distribution curve of the current reaching C_2 in the absence of lampblack. In this case only about 60% of the electrons retained approximately their initial velocity, while the majority of these have suffered a small energy decrease. Curve $B(2)$ shows the distribution after the grids and cages had been

² Gehrts, *Ann. d. Physik.* **36**, 995 (1911).

sooted. It is apparent that about 90% of the electrons have their initial velocity. The absolute magnitudes have no meaning, since the emission was much higher in the second case.

To demonstrate further the effect of carbon, distribution curves of the plate current were taken first without and then with lampblack. These are reproduced in curves $C(1)$ and $C(2)$, respectively, in which the plate current is plotted against the accelerating or retarding voltage between C_2 and P . $C(1)$ is similar to curves obtained by Lawrence⁸ with a very short Faraday cage. $C(2)$ shows a much better distribution, but it is poor compared to the curves above, which probably indicates that carbon is not a perfect absorbent. $C(1)$ is plotted to a much smaller current scale than $C(2)$, since the form of the curve and not the magnitude of the current is important.

The authors wish to express their thanks to Dr. G. Glockler for his help and advice; also to the Carnegie Institution of Washington for financial assistance received from a grant made to Prof. A. A. Noyes.

GATES CHEMICAL LABORATORY, CALIFORNIA INSTITUTE OF TECHNOLOGY,
PASADENA, CALIFORNIA,
October 29, 1926.

⁸ Lawrence, Proc. Nat. Acad. Sci. 12, 29 (1926).

THE ACTIVATION OF GASES BY ELECTRON IMPACT

INTRODUCTION

The purpose of this research was to study the chemical behavior of gases activated by electron impact and to measure the energy necessary for their activation. The general plan was to use an apparatus similar to that employed in the study of the reaction between copper oxide and active hydrogen by Glockler, Baxter, and Dalton.¹ The gases were introduced at pressures of 0.05 - 0.3 mm. of mercury into a four electrode tube connected with a liquid air trap and a Pirani pressure gauge. A four electrode tube was used in order that the energy loss of the electrons might be studied by making current potential curves as done by Franck² and others. With this arrangement it was possible to follow the course of any reaction which involved a change in the number of molecules or produced a product condensible in liquid air. It was of course not possible to use gases which would undergo reaction when exposed to the hot filament. The systems studied were: oxygen and carbon, carbon monoxide and hydrogen, nitrogen and copper. Only the first gave definite positive results and for this reason it will receive the most attention.

The author wishes to express his thanks to Professor Tolman, Dr. Glockler and Mr. Baxter for their assistance in this research; also to the Carnegie Institution of Washington for financial aid received through a grant made to Professor A.A. Noyes.

ACTIVATION OF OXYGEN

Experimental Procedure: - The oxygen was obtained by heating mercuric oxide some of which was contained in a bulb attached to the apparatus. The mercuric oxide had been previously prepared in the apparatus by boiling mercury for some time with well dried tank oxygen.

Except in Experiment 2 (see Table I) the carbon was present in the form of lamp black deposited on grid, G_2 , with a smoky gas-oxygen flame. In the case of Experiment 2 graphite which had been previously ignited in vacuo was used.

The apparatus used is shown diagrammatically in Figure I. Within the tube all metal parts are of platinum except for the short length of tungsten wire used to bring the leads through the glass. The source of electrons is F, operating on a potential drop of about 2 volts. Around this is a cylindrical electrode, G_1 , with a circular grid of 50 mesh gauze 0.1 cm. from the filament. The next electrode is also cylindrical and has in the end a circular grid, G_2 , of the same mesh as G_1 . The distance from G_1 to G_2 is about 4 cm. One millimeter behind G_2 is the plate, P.

The electrical connections are shown in the diagram, I_1 , I_2 , I_3 and I_4 are galvanometers. The potential between filament and G_1 is established by means of a storage battery and resistance in parallel and is calculated by the expression

$$P. D. = \frac{R_1}{R_1 + R_2} (E_1 - I_1 R_2)$$

where R_1 and R_2 are the resistances indicated in the diagram, E_1 is

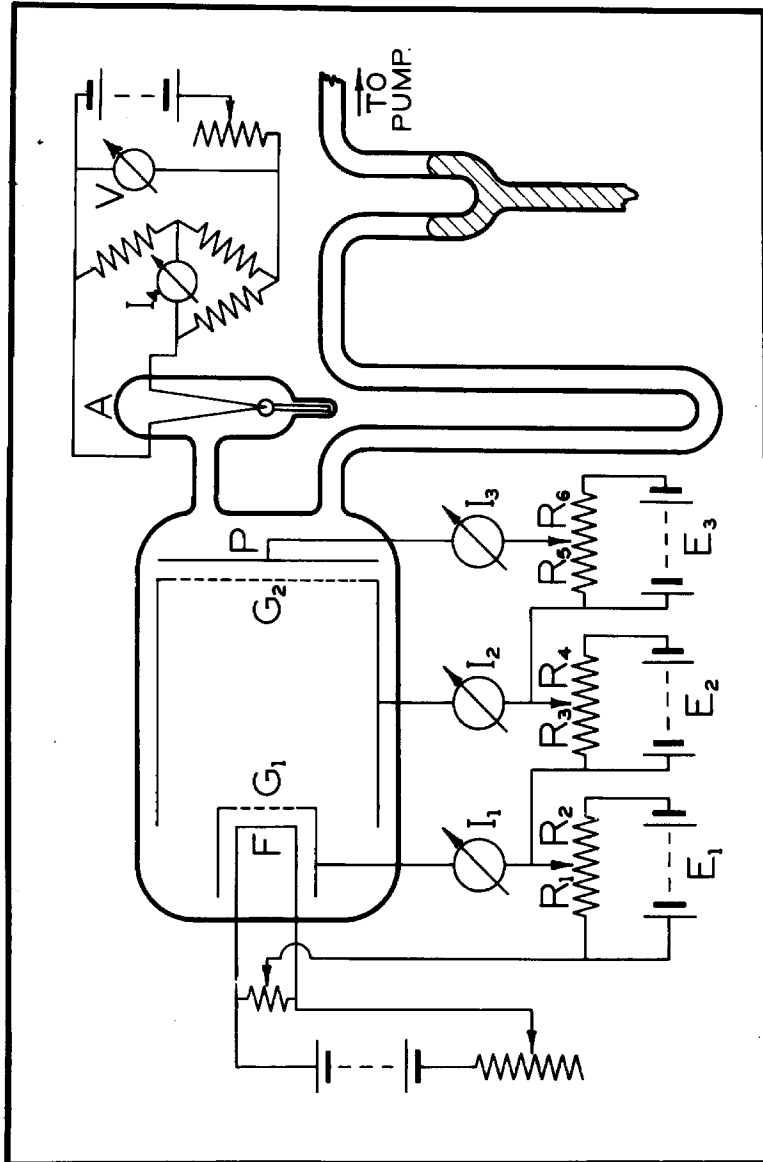

FIGURE I

the potential of the battery and I , is the current between the filament and the first electrode.

A connecting tube leads from the apparatus to the Pirani pressure gauge, A, which consists of a fine platinum wire about 18 cm. long and 0.003 cm. in diameter. In the original experiments the wire was sealed in a straight glass tube 0.5 cm. in diameter. This form while quite sensitive was undesirable since when heated the wire became slack so that its position with respect to the walls and hence the heat conductivity and apparent pressure were variable. These difficulties were avoided by the arrangement shown in Figure I in which the wire is stretched and centered by a small weight sliding in a glass tube. To maintain the walls at constant temperature the tube containing the wire was placed in a thermos bottle filled with water. The slight heating due to the Pirani wire did not raise the temperature of the water appreciably. The connections are shown in the figure and are those recommended by Campbell.² The Pirani wire is in one arm of a Wheatstone bridge the other three resistances of which are fixed. The voltage, V , necessary to balance the bridge is then a measure of the pressure. Over the pressure ranges for which the instrument was used (0.01 to 0.3 mm.) the pressure is a nearly linear function of $V^2 - V_0^2$ where V_0 is the voltage to balance the bridge when the pressure is negligible. If absolute pressure measurements are desired the gauge must be calibrated against a McLeod gauge with each gas used.

Another connecting tube leads from the apparatus to a liquid air trap, a mercury cut-off, devices for introducing various gases, a McLeod gauge, another mercury cut-off, and the pumps.

To prevent changes in pressure due to changes in temperature the electron tube was surrounded by a water jacket through which a stream of tap water was passed.

The experimental procedure was in general the following. The apparatus was pumped out to about 10^{-5} mm., the filament lighted, and the trap at the tube immersed in liquid air. The gas was introduced, pressures being read both on the McLeod and on the Pirani gauge. The mercury cut-off at the tube was then closed and the rate of pressure change determined with various accelerating voltages between the filament and first grid. These rates were followed by measuring the rate of deflection of the galvanometer I_4 when the bridge was balanced. Using a sensitive galvanometer changes of pressure of 10^{-5} mm. caused deflections of 1 cm.

In the work on oxygen a great deal of difficulty was encountered in obtaining sufficient electron emission to produce measurable chemical effects. In some cases the emission of a filament was less than one hundredth of its value in the presence of hydrogen gas.

Experimental Results: - The results of the experiments with oxygen were as follows. It was found that with the filament heated the pressure decreased steadily, even although no accelerating potential was applied. Attempts to remove this zero rate by running for some time

with high oxygen pressure and by cooling the tube failed, so it was decided to correct the other rate readings by subtraction. This was not difficult since the zero rate remained nearly constant during the course of the run. This initial rate was, however, of the same magnitude as the rate due to electronic excitation. From 0 up to 8 volts there were no important changes in the rate. Most experiments to be sure showed some increase between 2 and 5 volts but these effects were small compared to the changes above 8 volts and were not definitely reproducible. Around 9 volts in all the experiments (see Table I) the rate began to increase with the voltage, rapidly at first and then more slowly up to the highest potentials investigated. Figure II shows two of the runs. The voltages are plotted as abscissae and the rates of pressure decrease in arbitrary units as ordinates.

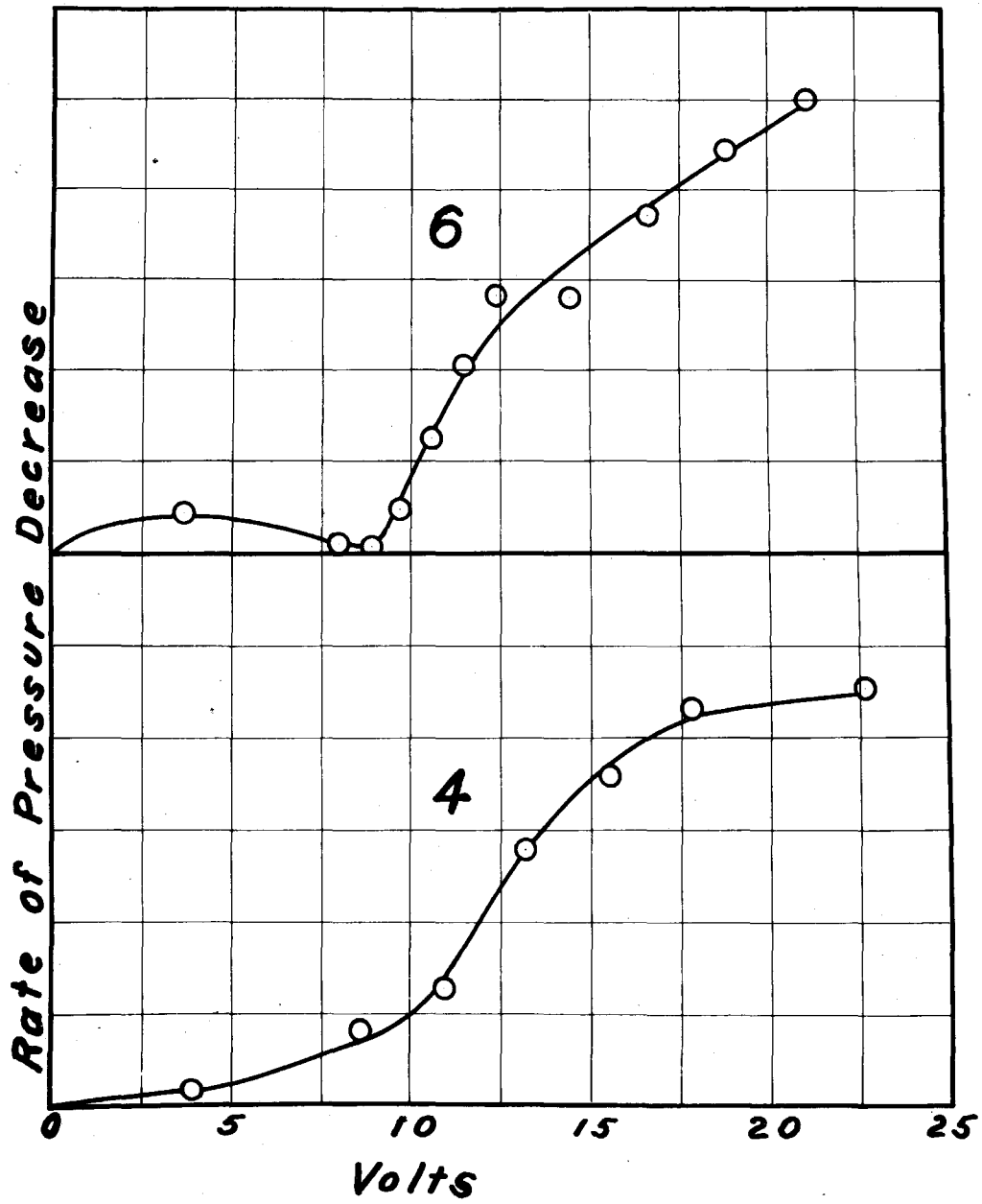

FIGURE II

The numerical results of the experiments in oxygen gas are summarized in Table I.

TABLE I

| Experiment Number | Pressure of O ₂ mm | Corrected critical voltage |
|-------------------|----------------------------------|----------------------------|
| 1 | 0.09 | 8.7 |
| 2 | 0.09 | 10.1 |
| 3 | 0.09 | 10.8 |
| 4 | 0.09 | 9.2 |
| 5 | 0.09 | 8.5 |
| 6 | 0.24 | 9.3 |
| 7 | 0.22 | 9.2 |
| 8 | 0.23 | 9.2 |
| 9 | 0.12 | 8.6 |
| Weighted mean | | 9.2 volts |

This table contains all the experiments except one in which the "B" batteries ^{were} ~~became~~ discharged. Experiments 6 to 9 are the most accurate and have been given twice the weight of the others in determining the mean, since they were made with the improved Pirani and with the tube water-cooled. Also in the earlier runs the voltage of the "B" battery was not always accurately known.

The values of the corrected critical voltages were obtained as follows. The difference between rate at a given voltage and the zero rate was divided by the total emission to compensate for the increase of this with increasing voltages. The values so obtained were plotted against the corrected voltage. The voltage applied to the tube is not a true measure of the energy of the electrons since some energy is required to remove the electrons from the filament. This initial

velocity correction was determined by taking the voltage at the foot of the curve obtained by plotting the values of the total emission against the voltage in the region from 0 to 3 volts. The average of three determinations gave 0.85 volts for this correction. Subtracting this value from the applied potential gives for practical purposes the maximum voltage of the electrons and is spoken of as the corrected voltage. The maximum value is of interest rather than the average, which is about a volt lower, since the critical voltage is taken as the point where the rate first starts to change, which is the point at which the fastest electrons just attain the critical value.

In Figure II the rate of pressure decrease in arbitrary units is plotted against the corrected voltage. The data are those of Experiments 4 and 6. In curve 6 the foot of the curve is very sharp and the potential at which reaction starts can be easily determined. In case 4 where this is not true the foot was determined by extending the rapidly rising nearly linear part of the curve till it intersected the voltage axis.

The Reaction Product: - It is natural to suppose that the product of the reaction is carbon dioxide, since carbon monoxide will not be frozen out by liquid air at these pressures. The following experiments substantiated this supposition. The product from a number of runs was allowed to accumulate in the liquid air trap, the residual oxygen was pumped out, the mercury cut-off at the pumps closed, and the liquid air removed. A series of pressure readings was then made on the McLeod

gauge with the mercury at different heights. The product behaved as a perfect gas up to pressures of 18 cm. and so cannot have been water vapor. There was no permanent change in pressure on lighting the filament which eliminates ozone as a possibility. Finally some of the product was collected in a small side tube, cooled in liquid air, sealed off, and opened under barium hydroxide solution. A small quantity of a white precipitate of barium carbonate was obtained. Thus the product must consist at least in part of carbon dioxide.

Discussion: - It is interesting to compare the value 9.2 volts at which reaction starts with the known energy levels of oxygen. The band spectra of oxygen have been only partially worked out. There are electronic levels at about 1.7 volts and at 6 volts.⁴ It is thought that the convergence limit of the oscillational states of the 6 volt electronic level corresponds to the energy for dissociation into two normal atoms. This gives about 7 volts for the work of dissociation of the normal molecule. Above 6 volts there are no levels given till ionization into O_2^+ between 14 and 15 volts. Thus spectroscopically there are no energy levels yet given in the neighborhood of 9 volts though it is probable that such exist.

The work of various investigators on the determination of the critical potentials of oxygen by electron impact methods is not in good agreement. For the first critical potential, values varying from 7.9 to 9.2 volts have been reported.⁵ However the later work which is probably the more reliable gives values close to 8 volts. A second critical potential is found by most observers at about 15.5 volts and is accepted as the ionization potential.⁶

It is seen that except for some early, rather unreliable work none of the above levels are in agreement with the potential at which reaction was found to start. To be sure this potential is only 1 volt greater than the best value of the first resonance potential as determined by electron impact experiments, but it seems improbable that the error could be that large. Furthermore if we accept the spectroscopic value of 7 volts as the energy necessary for dissociation into normal atoms, the process cannot consist of dissociation into excited atoms since there are no suitable atomic levels to take up the 2 volt excess, the first resonance of the oxygen atom being 9.1 volts. If the 2 volt excess could go into kinetic energy we might have dissociation as the primary process. However, it is most probable that we are dealing here with a previously unrecorded critical potential of the molecule.

Work is now being started on current potential curves in oxygen and this will aid in interpreting the process.

One mechanism may be advanced which will account for the critical reaction velocity of 9.1 volts. If, either by electron impact or by the glowing filament, oxygen is dissociated, the atomic oxygen so formed would be activated by 9.1 volt electrons. This process seems highly improbable since it assumes that a sufficient quantity of atomic oxygen would be formed and that it would not itself react at an appreciable rate.

CARBON MONOXIDE AND HYDROGEN

Marshall⁷ showed that hydrogen gas activated by collisions of the second kind with mercury in the 2^3P_1 state reacted with carbon monoxide to form formaldehyde. It seemed probable that activation of hydrogen or carbon monoxide by electron impact would lead to the same reaction, but this did not prove to be the case.

The carbon monoxide was prepared by the action of formic acid on sulfuric acid. It was passed through potassium hydroxide containing some potassium pyrogallate to remove carbon dioxide and oxygen, and then through concentrated sulfuric acid and over phosphorus pentoxide for drying. The gas was admitted to the apparatus through stop cocks.

The hydrogen was introduced by heating a palladium tube attached to the apparatus to bright redness in a gas flame. The tube used was the same as that described previously in the work with oxygen. It was not water cooled and the old form of Pirani gauge was used. Before commencing this work the tube was run at a high potential with hydrogen for some time to remove adsorbed oxygen. The procedure was similar to that used with oxygen. The gases were studied at pressures of about 0.05 mm.

No reaction was found below the potential at which an arc appeared (25 to 30 volts). At this potential carbon monoxide alone underwent a pressure decrease so that we can only say that reaction does not occur at the lower resonance potentials of either hydrogen or carbon monoxide.

ACTIVE NITROGEN

An attempt was made to produce chemically active nitrogen by electron impact. It was hoped that the value of the critical potential might shed some light on the question of the nature of active nitrogen. The object of the investigation was not accomplished since at the highest electron currents obtainable with the apparatus used, measurable quantities of chemically active nitrogen were not produced at interpretable potentials. The results are, however, of sufficient interest to justify a brief mention of the experiments.

It was first necessary to find a suitable reaction. For this purpose various substances were introduced into a tube connected with a Pirani gauge and containing nitrogen gas at about 1.2 mm. pressure. Ordinary cylinder nitrogen was used after drying over phosphorus pentoxide. It was admitted to the apparatus through stop cocks. The nitrogen was then activated by an electrodeless discharge. The production of active nitrogen was proved by the appearance of the afterglow. When copper foil was present under these conditions the pressure fell to about 10^{-3} mm. in a few minutes. There was no appreciable increase in pressure after standing several days. Thus active nitrogen forms with copper a stable compound and this furnished a very convenient reaction to study.

The experimental arrangement was that used by Glockler, Baxter, and Dalton³ except that the copper surfaces were cleaned in acid instead of being oxydized. Pressures of nitrogen from 0.1 to 0.3 mm. were used. There was practically no change in pressure, however, till the accelerating potential reached the value at which a luminous discharge set in,

which was at 20 to 30 volts depending on the pressure. Thus, for example, in an experiment in which the pressure of nitrogen was 0.17 mm. a run of 2 hours with 20 volts accelerating potential and 1 m.a. emission produced a change in pressure of only 5×10^{-3} mm. This is too small to permit rate measurements of the kind we had been making, and might have been accounted for simply by temperature changes which occurred over that period of time. The fact that a pressure decrease started when a luminous discharge set in gives no information as to the energy of active nitrogen except that this is less than 25 volts, since the arcing-potential depends on the pressure and geometry of the tube, and also since a great many energy states are then present.

SUMMARY

The results of the experiments on the hydrogen-copper oxide reaction and on the effect of passage through small openings on the velocity distribution of an electron beam are summarized on pages 8 and 12 respectively.

An active form of oxygen capable of reacting with carbon to form carbon dioxide is produced when oxygen gas is subjected to bombardment with 9.2 volt electrons. The primary process in the activation is probably the excitation of an electronic level in the molecule.

Mixtures of carbon monoxide and hydrogen when subjected to electron impact failed to undergo a measurable reaction till the arcing potential was reached.

It was found that active nitrogen reacts with copper to form a non-volatile, stable compound. An attempt was made to produce active nitrogen by electron impact using the formation of this compound as an indication of its presence. Below the arcing potential no evidence for its formation was found.

REFERENCES

1. This Thesis, 3.
2. For a complete discussion of these methods see Franck and Jordan, "Anregung von Quantensprungen durch Stöße", Springer, Leipzig, (1927).
3. Campbell, Proc.Phys.Soc.London, 33, 287 (1921).
4. Birge, Bulletin of the National Research Council, No. 57, 244 (1926).
5. Foote and Mohler, Bureau of Standards Publication, No. 400 (1920).
Boucher, Phys.Rev., 19, 202 (1922).
Franck and Hertz, Verb.d.D.Phys.Ges., 15, 34 (1913).
Hughes and Dixon, Phys.Rev., 10, 502 (1917).
6. Smyth, H.D., Proc.Roy.Soc.London, A 105, 116 (1924).
7. Marshall, J.Phys.Chem., 30, 1634 (1926).