

I THE MASS OF THE ELECTRIC CARRIER IN METALS  
II THE LACK OF EFFECT OF A MAGNETIC FIELD ON THE  
DIELECTRIC CONSTANT OF HCl AND NO.

Thesis

by

Lewis M. Mott-Smith

In partial fulfillment of the requirements for  
the degree of Doctor of Philosophy

CALIFORNIA INSTITUTE OF TECHNOLOGY

Pasadena, California

1926

A FURTHER STUDY OF THE INERTIA OF THE ELECTRIC CARRIER  
IN COPPER.

TABLE OF CONTENTS

I. Introduction

1. The Berkeley Experiments
2. The Washington Experiments
3. The General Nature of the Pasadena Experiments

II. Description of the Apparatus

4. The Location
5. The Cement Pier
6. The Oscillating System
7. The Driving Mechanism
8. The Earth Inductor
9. The Coil
10. The Electrical Connections
11. The Amplifier
12. The Galvanometer
13. The Set Up for Calibration

III. Experiments on the Effect of the Earth's Field.

14. Nature of Expected Effects
15. The Experimental Work
16. Method of Plotting the Results
17. Plots of the Data
18. General Discussion of the Data
19. Phase of the Component of the Electromotive Force Due to the Earth's Field.

20. Magnitude of the Component of the Electromotive Force Due to the Earth's Field.
21. Conclusion as to Effect of Earth's Field.

#### IV. Elementary Theory of the Inertia Effect

22. The Electromotive Force in a Stationary Conductor
23. The Effective Electromotive Force in an Accelerated Conductor
24. Comparison of Electromotive Forces Obtained in Effect and Calibration Runs.

#### V. Experimental Results on Amplitude and Phase of Electromotive Force Due to Inertia of Carriers.

25. Results from Runs of July 23 to August 24, 1925.
26. Results from Runs of February 18 to March 5, 1926

#### VI. Critique of the Experimental Work

27. Vibration of the Coil
28. Play in Cylinder Bearings
29. Asymmetry in Cylinder
30. Effect of Centrifugal Force
31. Photographic Analysis of Motion in Effect Runs
32. Effect of Direct Earthing of Cylinder
33. Tests with Double Tip of Coil
34. Tests with Field from External Magnet
35. Tests with Laminated Cylinder
36. Effect of Possible Currents in Nearby Circuits *Disturbances*
37. Behavior of Galvanometer as Affected by External Circuit
38. Effect of Changing Frequency in Calibration
39. Effect of Amplitude of Calibration Oscillation
40. Effect of Changes in Alignment
41. Effect of Magnitude of Amplification
42. Test of a Nearby Circuit in Calibration

- 43. Photographic Analysis of Motion in Calibration Runs
- 44. Phase of Calibration Electromotive Force
- 45. Conclusions as to Experimental Work

VII. Critique of the Theory

- 46. Nature of the Mass Associated with the Carriers
- 47. Forces on the Electron
- 48. The Effect of Torsional Strains

VIII. Conclusion

A FURTHER STUDY OF THE INERTIA OF THE ELECTRIC CARRIER  
IN COPPER.

By Richard C. Tolman and Lewis M. Mott-Smith

I. Introduction

1. The Berkeley Experiments. - The production of an electromotive force in an accelerated metallic conductor, due to the inertia of the electrons in the conductor, was first demonstrated by the work of Tolman and Stewart<sup>1</sup> at Berkeley, who measured the pulse of electric current produced by suddenly stopping a coil of wire rotating around its axis. Their experiments included work on a number of different coils of copper, silver and aluminum wire. The pulse of current was always found to be in the direction which would be predicted on the basis of a mobile negative electron for the carrier of electricity in these metals, and the mass of the carrier as calculated from the magnitude of the pulse came out for the three metals tested about 15% higher than the known mass of an electron in free space.

The most serious chance of error in the Berkeley experiments would seem to be the possibility of electromotive forces produced in some manner not thoroughly understood by the buckling of the wire or the forces between the wire and its insulation at the time of stopping of the coil. Some evidence of such disturbing effects would seem to be given by the work of Tolman and Stewart, since they found that their results were more concordant the more carefully they wound their coils and the more care they gave to the impregnation of the coil with paraffin or shellac. Further evidence as to such possible misbehavior of the insulating material will be given in the present article.

---

<sup>1</sup>Tolman and Stewart, Phys. Rev., 8, 97 (1916); 9, 164 (1917).

2. The Washington Experiments. - The above chance of error was eliminated in the later experiments of Tolman, Karrer and Guernsey<sup>2</sup> made at Washington, who oscillated a cylinder of copper around its axis and determined the electromotive forces produced in it by surrounding it with a secondary coil of many turns of fine wire which was connected through an amplifier with a vibration galvanometer. These experiments also seemed to demonstrate an electromotive force due to the inertia of the electrons, and the average value for the mass of the carrier came out from these measurements about 8% lower than the mass of the electron in free space.

In these Washington experiments only the effective amplitude of the alternating current produced in the secondary was measured and this compared with the current produced in the secondary by a suitable method of calibration. Hence since the phase of the current was not known, it is impossible to conclude from these experiments, as from the Berkeley work, that the direction of the effect is necessarily that which would be predicted on the basis of a negative charge for the mobile carrier.

The Washington experiments also suffered from an uncertainty as to the best method of correcting for the accidental electromotive forces always present in the coil, which produced at all times a varying deflection of the galvanometer beam, even though the apparatus was not running. The method adopted was to measure the width of the galvanometer beam when the apparatus was stationary (zero effect) just before or after a series of measurements and then correct simply by subtraction. It is evident, however, that a method of balancing out that part of the electromotive force of real interest would be superior.

Finally the time available for the Washington experiments made it impossible to carry out a complete study of the effect of the earth's magnetic field. To eliminate effects from this source, the oscillating cylinder was set with its axis as nearly parallel as possible to the direction of the earth's field, and the axis of the coil was then aligned parallel with the axis of the cylinder. It was believed that this

---

<sup>2</sup>Tolman, Karrer and Guernsey, Phys. Rev., 21, 525 (1923).

arrangement would eliminate accidental effects due to motion in the earth's field, provided exact parallelism could be attained, and indeed the work to be described in the present article substantiates this point of view. Time did not permit, however, a satisfactory determination of the magnitude of the error actually introduced by the impossibility of obtaining absolute parallelism. Preliminary attempts were made to neutralize the earth's field with large Helmholtz coils, and changes in the magnitude of the effect were observed to accompany changes of the D.C. current in these coils. At the time, this effect was ascribed to eddy currents in the cylinder produced by lack of homogeneity in the field introduced by the compensating coils. The true nature of this effect, however, has now been found, and will be made apparent in the present article.

3. The General Nature of the Pasadena Experiments. - In the present experiments, which were made at Pasadena, we have again oscillated the copper cylinder parallel to its axis and surrounded<sup>it</sup> by a secondary coil of many turns of fine wire, but have overcome the above three difficulties encountered in the work at Washington by methods that will be described below.

In order to determine the phase of the effect we have balanced the alternating electromotive force in the coil against an alternating electromotive force produced by an earth inductor rotating in synchronism with the oscillation of the cylinder, arrangements being made so that we could adjust the amplitude and phase of the balancing electromotive force.

This method of measuring the effect also eliminates uncertainty as to the right way of correcting for the "zero effect" which keeps the galvanometer oscillating to some extent all the time, even when the apparatus is not running, since we only balance out the electromotive force of actual interest. Under favorable conditions there was almost no difference between the widening and "kicks" in the band of light from the galvanometer when the balance had been made with the apparatus running and the behavior of the band when the apparatus was stationary.

Finally, we have made an elaborate study of the effect of the earth's field on the magnitude and phase of the effect, by changing the alignment of the cylinder with respect to the earth's field and the alignment of the coil with respect to the cylinder, and by rotating the coil around its axis. Indeed, the investigation of such effects forms a considerable portion of the work to be described in this article. In a general way it may be said that the correct magnitude of the effect will be obtained provided the cylinder is exactly parallel to the earth's field or provided the (electrical) axis of the coil is parallel to the cylinder. If both alignments are made parallel the results are of course that much better. This explains the success of the Washington experiments, since the attempt was there made to have both alignments parallel.

## II. Description of the Apparatus

In order to permit the intelligent criticism of work so full of difficulties as this, it seems desirable to describe the apparatus and experimental work in considerable detail. This is especially true, since such work always contains annoying minor lacks of consistency and their possible significance can only be estimated in the light of all the facts.

4. The Location. - Just as in Washington it was found impossible to carry out work of this nature in a laboratory building, owing to large continuous accidental variations in electromagnetic conditions which keep the galvanometer always in violent oscillation when connected through the amplifier to the coil. A somewhat isolated location was found on the campus, however, which was reasonably satisfactory, and the apparatus was housed in a small wooden building with a floor space of 16 by 12 feet and 10 feet high, with its axis pointing towards the magnetic north.

5. The Cement Pier. - The apparatus was mounted on the northern face of a cement pier, this face being approximately parallel to the magnetic dip. The height of the pier was 9 feet 4 inches and its base 5 feet 4 inches by 2 feet sloping to 2 feet by 10½ inches at the top, with a projection of 1 foot at the bottom on the west side carrying the Pelton water wheel and other accessory apparatus for driving



the oscillating system, as shown in Figures 1 and 2. The pier was carried on a cement base 6 feet 3 inches by 5 feet in area and 2 feet deep in the ground and this in turn on a concrete foundation. Holes through the pier and its base were left to allow for the installation of compensating coils if desired, and brass insets were provided for bolting apparatus to the pier.

In front of the northern face of the pier a cement-lined pit was provided as shown in Figure 1 to carry the lower end of the torsion rod. The pit was 4 feet by 2 feet in area by 4 feet 6 inches deep.

The foundations of the pier were constructed of ordinary concrete, but the pier, its base, and the walls of the pit were constructed from neat cement, since the sand available was found to be very paramagnetic. The cement itself was only slightly paramagnetic. We desire to thank Prof. S. R. Williams now of Amherst College for his kindness in testing the magnetic properties of the sand <sup>and</sup> ~~the~~ cement.

6. The Oscillating System. - The oscillating cylinder was the same one used in Washington, provided, however, with new end plates carrying the pinions for the bearings necessary for the rotary oscillation. The cylinder was made from a copper billet cast and then forged to a fine homogeneous structure at the Washington Navy Yard. The cylinder was 9 1/8 inches long with an outside diameter of 4 inches and an inside diameter of 3 inches.

The end plates were constructed from castings of phosphor bronze and were sweated into the ends of the cylinder. The pinions were 1 inch in diameter by 2 1/2 inches long and ended in a slotted plate arranged for <sup>laying</sup> keeping them to plates on the ends of the torsion rods which supplied the restoring force for the oscillation.

The cylinder rotated in bearings of gun metal bronze which were carried in brass pillow blocks mounted on a cast brass bed plate bolted to the pier.

The restoring force for the oscillation was supplied by the twisting of long torsion rods clamped at top and bottom. A long period of experimentation was given to attempts to use helical springs instead of the torsion rods, which would have had the advantage of greatly shortening the length of the apparatus. To get the necessary restoring force, however, these springs had to be very heavy and could only be made by machining out from a solid bar of Tobin bronze. Although they gave fairly satisfactory service for a time, finally a fracture always developed in one spring or the other. In addition the changes in cross section of the springs by twisting, thus cutting the earth's magnetic field, lead to disturbing currents, which, however, were at least partially eliminated by insulating the ends of the springs.

The torsion rods finally employed were the same ones used in Washington, made from special non-magnetic "Navy Brass", hexagonal in cross section, 5/8 inch from flat to flat. The distance from end to end between clamps was 14 feet 10 inches. And the period of oscillation was about 20 cycles per second.

The phosphor bronze for casting the end plates of the cylinder had a magnetic susceptibility of  $-1.5 \times 10^{-7}$ , the red brass for casting the bed plate and the pillow blocks had a susceptibility of  $3 \times 10^{-7}$ , and the "Navy Brass" torsion rods also had a susceptibility of  $3 \times 10^{-7}$ . We also have to thank Professor Williams for these tests.

7. The Driving Mechanism. - The apparatus was driven by a 6 inch Type F Pelton water wheel specially constructed out of bronze so as to be non-magnetic and indeed provided with bronze ball bearings.

The Pelton wheel was first mounted on a separate base and the apparatus driven by belts. Serious accidental electromotive forces were, however, introduced into the coil by the electrostatic charging of the leather belts. These were not satisfactorily eliminated by metallic shielding of the belts, but could be pretty well

removed by frequent wetting of the belts, a procedure with its attendant spray, however, which was not permanently satisfactory. Attempts to keep the belts wet with some hygroscopic substance and to use other materials than leather for the belts were also unsatisfactory. For this reason it finally seemed best to resort to a direct drive from the Pelton wheel. The complications of doing this with the wheel set on a separate base finally led us to mount the wheel on the west projection of the main pier. This had the disadvantage of introducing possible vibrations in the cylinder. The pier, however, was very massive and with our present accuracy anyway we never found any evidence of a disturbing effect from this cause.

The final location of the Pelton wheel will be seen from Figures 1 and 2. The shaft of the wheel was connected through two universal joints, to allow for any slight lack of alignment, with a shaft carrying a rotating disk provided with tapped holes at different radii to take the wrist pin for the connecting rod which drove the cylinder. The other end of the connecting rod went to a wrist pin on a rocker arm which oscillated about the axis of the cylinder, a friction clutch being provided by which the rocker arm could be engaged with the oscillating system after the Pelton wheel had reached a sufficient frequency of rotation, as shown in Figure 2.

5. The Earth Inductor. - The electromotive force used for balancing the electromotive force induced in the coil by the oscillating cylinder was generated in a rotating earth inductor driven synchronously with the cylinder. This inductor consisted of a coil of 126 turns of about no. 23 copper wire wound on a thin wooden spool with an average diameter of 9.8 cm.

This coil was mounted in a slot in a shaft operated, through a pair of spiral gears of one to one ratio, by the main shaft driven by the Pelton wheel. The nature of the arrangement will be seen from Figure 2, and more diagrammatically from Figure 3, where it will be noted that the coil rotated in such a way as to cut the earth's field.

The rotating shaft which carried the coil was provided with two insulated collecting rings leading through graphite brushes to the potentiometer slide wire from which the desired potentials could be tapped off. The resistance of the coil and the brushes was approximately 5 ohms and was steady while running, when operating satisfactorily, within a few hundredths of an ohm. Some care, however, had to be taken in cleaning and oiling the rings and adjusting the tension on the brushes, and smoothing them with emery paper from time to time to maintain satisfactory operation.

The shaft carrying the earth inductor was mounted in a carriage sliding in ways parallel to the axis and adjustable in position by a lead screw. The longitudinal motion which could thus be given at will to the shaft changed of course the relative position of the two spiral gears, thus rotating the earth inductor and permitting an adjustment of the phase while the apparatus was in operation. We are indebted to Dr. Arthur Klein for suggesting to us this method for phase adjustment.

The eastern end of the shaft carrying the earth inductor was provided with a pointer and <sup>or</sup> protraction-scale which permitted a reading of the phase setting used for the balance. A light extension from the western end of this shaft drove a mechanical technometer which was set a couple of feet away from the earth inductor to avoid possible disturbances.

9. The Coil. - The coil surrounding the cylinder was a new one specially built for this work. The spool for the coil was constructed of "micarta". It had an overall length of  $9 \frac{1}{8}$  inches, the end disks being  $\frac{3}{8}$  inch thick. The outside diameter was 7 inches, the inside diameter  $4 \frac{1}{8}$  inches, and the wall thickness of the central tube  $\frac{1}{16}$  inch.

It was very carefully wound in one length with soldered joints, with 18 lbs. of no. 35 enamel coated wire, with a total of 260,772 turns, giving a resistance of 207,300 ohms and an approximate length of 67 miles. We desire also here to thank Mr. Julius <sup>a</sup>Person for the skill and care with which this coil was constructed.

The coil was mounted in a cradle with adjusting screws for tipping its axis in any desired direction, and for aligning it lengthwise and sidewise.

Experiments were at first made with the cradle bolted to the cement pier with thick washers made from rubber stoppers to eliminate vibration, and pretty satisfactory results obtained. Finally, however, to remove any possibility of vibration in the coil, the cradle was hung from an overhead wooden frame which was itself supported on wooden uprights that went through the floor of the house directly into the earth without coming in contact with the floor. All the results reported after August 11, 1925 were made with this new support for the coil.

10. The Electrical Connections. - The electrical connections for measuring the effect are shown schematically in Figure 3. The four double through switches were ordinary porcelain base switches.

Switch no. 1 was arranged so that when thrown down it would connect the earth inductor through the graphite brushes with the slide wire AB, from which the desired potential, corresponding to the length AC could be tapped off. to neutralize the effect from the coil. When switch no. 1 was thrown up it connected the earth inductor through the brushes directly with a test set for measuring resistances so that a frequent check could be made of the operation of the brushes.

Switch no. 2 when thrown down connected the coil into the amplifier circuit, and when thrown up cut the coil out of the circuit so as to permit a direct reading of the amplitude of oscillation of the galvanometer from the generator coil alone, thus permitting a test whenever desired of the operation of amplifier and galvanometer when acted on by a known electromotive force.

Switch no. 3 when thrown down connected the earth inductor into the amplifier circuit and when thrown up <sup>cut</sup>shorted the earth inductor. <sup>act</sup>

Switch no. 4 was a reversing switch which permitted a reversal of the direction of the electromotive force from the slide wire if this was desired to obtain a balance. Of course a careful record of the position of switch no. 4 was always kept.

The slide wire was a Leeds and Northrup, Kohlrausch type slide wire, wound on a cylindrical drum with a resistance of approximately 32 ohms. The inductance of this helical slide wire was too small to introduce any difficulty.

11. The Amplifier. - The amplifier consisted of three stages with resistance coupling, connected as shown in Figure 4. The use of separate A-batteries for heating the filaments of the tubes and separate B-batteries for the three plate circuits as used in Washington would at first sight seem a better arrangement to obtain a non fluctuating degree of amplification. As a matter of fact, however, a fluctuation in the first stage of amplification produces much more effect on the total amplification than a fluctuation in the later stages. Hence separate batteries would give <sup>no</sup> positive advantage, while the increased number of batteries which can get out of steady conditions is a positive detriment. The tubes used in the first two stages were Western Electric Type V (voltage amplifiers), and that in the last stage a Western Electric Type J tube. The resistances, condensers and batteries used were as indicated in the figure, although the grid leaks were somewhat varied from time to time. The coupling resistances were Western Electric Lavite resistances.

The amplifier was connected through a transformer with the vibration galvanometer. The impedance of the primary of the transformer was about 20,000 ohms (25~) and the impedance of the secondary about 2,400 ohms (25~).

12. The Galvanometer. - The vibration galvanometer manufactured by Leeds and Northrup was the same one used in Washington. It was mounted with a specially light suspension so as to reduce the frequency to the desired value. It was provided with a concave mirror which was illuminated with a single filament lamp, the total

distance from mirror to ground glass scale being 13 ft. 10 inches. The D.C. resistance of the galvanometer was 765 ohms.

13. The Set Up for Calibration. - The calibration of the apparatus was obtained by setting the cylinder and coil transverse to the earth's magnetic field and oscillating the cylinder so as to cut the earth's field and thus produce a known electromotive force in the cylinder.

For this purpose one end plate of the cylinder was bolted to the face of the pier, above the earth inductor, so that the cylinder was perpendicular to the earth's magnetic field as shown in Figure 5. The coil was hung in its adjustable cradle from the vibration-free cross truss so as to surround the cylinder, and arrangement made to oscillate the cylinder through a small angle so as to cut the earth's field.

The small oscillation needed was made possible by a very slight bending in the pinion shaft between the pier and ~~and~~ cylinder. The necessary motion was imparted to the cylinder through<sup>2</sup> a very light rod attached to a stirrup on the outer pinion shaft. This was driven by a cam arrangement as shown in detail in Figure 5. The cam plates were cut at an angle and set off center so as to give a pure harmonic up and down motion, the lower cam being driven by direct connection through universal joints with the main shaft of the turbine. The adjustment was always made so that the cylinder was permanently strained down enough so as to be pulling up throughout its stroke. In addition an extra spring was provided as shown in the figure to keep the rocker arm in contact with the end of the shaft of the upper cam plate.

The amplitude of oscillation was measured optically. The light from a horizontal filament in a single filament lamp was directed by a spherical mirror<sup>3</sup> on a plane mirror fastened on the moving end plate of the cylinder, thence the light proceeded to a mirror facing the cylinder, back to a second mirror on the end plate and then with two further reflections to a focus on a ground-glass scale, where the

---

<sup>3</sup>We wish to thank Dr. J. A. Anderson for his kindness in lending us this mirror.

amplitude was read. There were thus two reflections from the moving end plate and a total path length of 1389 cms. in the 1925 measurement and 1391 cms. in the 1926 measurements.

The electromotive force produced in the coil by the transverse oscillation of the cylinder was balanced both as to phase and amplitude against the same earth inductor as used for balancing the effect itself. Although the angle of transverse oscillation of the cylinder in calibration was only about  $9 \times 10^{-4}$  radians as compared with a circular oscillation of 0.6 radian in the effect runs, the slide-wire reading in calibration for balance was about 60 times as great as for the effect, which gives an idea of the extreme minuteness of the effect.

### III. Experiments on the Effect of the Earth's Field

14. Nature of the Expected Effects. - A large part of the experimental work to be described consisted in a determination of the electromotive forces introduced by the motion of the cylinder in the earth's magnetic field, when the apparatus was operated in the effect position. The nature of the results to be expected can be understood with the help of the diagram, Figure 6.

As already stated, in the effect runs the cylinder was set nearly parallel to the earth's field in order to avoid cutting any magnetic lines of force when the cylinder was oscillated about its axis. Of course an exact parallelism, however, was not obtained, and indeed can not be permanently achieved owing to the diurnal variation in the direction of the earth's field. For this reason we must always expect a small residual component of the earth's field perpendicular to the axis of the cylinder as indicated in the diagram. When now, we oscillate the cylinder about its axis, it is evident that we cut this residual field in such a way as to induce an alternating current flow longitudinally around the cylinder as indicated by the arrows.



This longitudinal flow of current has of course no effect on the coil, provided the axes of coil and cylinder are coincident. If, however, the coil is tipped with reference to the cylinder, the alternations in this longitudinal current can induce an alternating electromotive force in the coil. Thus for example in the case of the diagram, tipping the axis of the coil perpendicular to the plane of the paper will evidently introduce an electromotive force into the coil. Hence in general we must expect that the measured electromotive force in the coil consists of two components, the first being the one of main interest which is due to the inertia of the electrons in the accelerated metal, and the second being a superposed effect due to this cutting of the residual component of the earth's field by the moving cylinder.

This superposed effect will of course be zero when the axis of the cylinder is exactly parallel to the earth's field, even when the axis of the coil is not parallel to the cylinder. Furthermore, when the cylinder is not parallel to the earth's field, the superposed effect can be made zero by exact alignment of the axis of the coil with that of the cylinder. As already stated, this accounts for the success of the Washington experiments, since the effort was there made to secure both an exact parallelism with the earth's field and an exact alignment of coil with cylinder.

15. The Experimental Work. - In order to test the effect of the earth's field, a series of runs were made with the cylinder in its normal position, and also rotated at various small angles from that position by tipping the whole base plate and rebolting to the concrete pier, with the introduction of spacers if necessary. The spring in the torsion rods was sufficient to permit these small changes in angle, provided the end clamps were loosened and then retightened after the change in angle.

For each position of the cylinder, balances were then obtained with the axis of the coil tipped to different angles relative to the axis of the cylinder.

The angle of tip of the cylinder could of course be measured directly. To determine the angle of the coil with respect to the cylinder, at the beginning of a series of runs, the coil was first set parallel to the cylinder, with the help of a taper gage which could be inserted between the coil and cylinder. The various angles of tip of the coil were then measured with the help of two mirrors on the coil, and suitably placed telescopes and scales. The angles recorded are probably seldom in error by an amount much greater than 0.00025 radians, while the total range of tip was about 0.02 radians.

In all, 293 balances were made in this work, usually taken in pairs with a given setting of the coil. Of these, 7 balances occurring near together on the same day were discarded because of their highly erratic nature. All the other balances are recorded in the plots of the data.

After each balance the apparatus was stopped, the slide wire reading recorded, and the phase setting of the earth inductor determined. This phase determination was made by loosening the clutch and turning the earth inductor over by hand until the connecting rod was at the center of its stroke, as shown by the coincidence of scratches on the moving and stationary parts. The proper position of the scratches was assured by taking readings with the same scratches both on the forward and backward stroke. The readings thus taken all agreed within two degrees and the average of the two readings was finally used. The balances were all made with the apparatus running at approximately the same amplitude and frequency.

16. Method of Plotting the Results. - In accordance with the elementary theory presented above, we should expect the electromotive forces measured to consist of two components, one due to the inertia of the electrons and hence constant in magnitude and phase, with a given amplitude and frequency of oscillation, and the other due to the motion of the cylinder in the residual field and hence constant in phase through connection with the phase of the velocity, but variable in magnitude through

its double dependence on the angle of the cylinder and angle of the coil. Under the circumstances, it is evident that the combined electromotive force observed can be regarded as the sum of two vectors, one constant in magnitude and direction, and the other constant in direction but variable in magnitude (both positive and negative). Hence it is evident, if we plot the various measured electromotive forces as vectors radiating from the same center, that the ends of these vectors should lie on a straight line as shown in the lower part of the diagram (Figure 7). Furthermore, for a given setting of the cylinder with reference to the earth's field, it is evident that the component of the electromotive force which is due to the earth's field should be proportional to the angle of tip of the coil in any given plane. Hence if we plot this component against the angle of tip, we should obtain another straight line. This is shown in the upper part of the diagram, where the ordinates are the angle of tip and the abscissae are by the method of construction evidently proportional to the component of the electromotive force due to the field.

17. Plots of the Data. - The data obtained were plotted using the method described above and are presented in Plots Nos. 1 to 20. Of the 293 measurements made for the study in question, 7 as already stated were omitted because of their erratic character, and 3 fall so far off the diagram that their position has only been indicated by dotted lines. All the other measurements have been included in the plots. Except in the case of Plots Nos. 19 and 20, measurements obtained with the coil parallel to the cylinder appear on both the two separate plots which give the data obtained with the same setting of the cylinder, first tipping the coil north and south, and then east and west.

The angle of tip of the axis of the cylinder from its normal position, and the angle of tip of the axis of the coil in a north-south or east-west plane are indicated on the plots. The direction of motion of the upper end of the axis is always given.

The phase angles for the different electromotive forces are plotted from an arbitrary starting point. The horizontal base line in the plots pointing to the left corresponds to a reading of  $30^\circ$  on the protractor scale on the earth inductor carriage, provided switch no. 4 was down and the connecting rod was at the middle of its stroke, moving east. Readings taken under other conditions were corrected to the above state of affairs. (Readings taken in calibration runs are corrected to the conditions, switch no. 4 down, cylinder in center of stroke moving up.)

18. General Discussion of the Data. - It is evident from an examination of the plots that the measurements do agree reasonably well with the expectations outlined above. The fact that the termini of the electromotive force vectors do lie as well as could be expected on a straight line indicates that these electromotive forces can be regarded as the resultant of one constant component and a second component constant in phase but variable in magnitude. Furthermore the graphs in the upper part of the plots show that the magnitude of this second component is proportional to the angle of tip away from the parallel position. Finally it will be noticed that the magnitude of the effect of tipping the coil in the north-south plane is dependent on the magnitude of the tip of the cylinder in the east-west plane, and vice versa as would be expected. Indeed it was possible to find a setting of the cylinder (see Plots Nos. 16 and 17) so nearly parallel to the earth's field that tipping the coil in either direction had only a very slight effect on the electromotive force at all.

Before proceeding to a more detailed discussion of the data, it is also specially important to note that there is no indication that the electromotive force would ever drop to zero for any setting of the cylinder relative to the earth's field, ~~but~~ or any tip of the coil. This provides strong evidence for believing in the reality of a component of the electromotive force which is not due to cutting

the earth's field, but is presumably due to the inertia of the electrons. In addition it is evident that the measurements of amplitude and phase obtained when the coil and cylinder were parallel, as well as the values for these quantities that could be determined from the best lines drawn through the two sets of points on the plots, would give fairly concordant results for what is presumably the electromotive force of interest due to the inertia of the electrons. This electromotive force will be more fully considered in a later part of the paper.

19. Phase of the Component of the Electromotive Force Due to the Earth's Field.

Considering these data now in somewhat more detail, it is evident, in accordance with the simple theory outlined above, that the component electromotive force introduced by the earth's field is determined by the velocity of the cylinder, and hence the phase angle of this component should have the same value in all the experiments. An examination of the plots will show that this is approximately but not exactly true.

Using the arbitrary starting point for measuring the angular setting of the earth inductor already mentioned, the phase of the component due to the earth's field has the following values as determined from the slopes of the lower lines on the plots as given in Table I. (At the phase angle given the magnitude can of course assume both positive and negative values.)

Table I

No. of Plot	Date	Plane of Coil Tip	Phase of Component
1	July 23-24	N.S.	27°
2	July 23-24	E.W.	33
3	July 25	N.S.	23
4	July 25	E.W.	31
5	July 27	N.S.	27
6	July 27	E.W.	30
7	July 28	N.S.	34
8	July 28	E.W.	31
9	July 29-30	N.S.	31
10	July 29	E.W.	31
11	July 30	E.W. (N.S.)	-
12	July 30-31	N.S.	18
13	July 30-31	E.W.	24
14	Aug. 1	N.S.	30
15	Aug. 1	E.W.	-
16	Aug. 6	N.S.	-
17	Aug. 6	E.W.	47
18	Aug. 20-21	N.S.	32
19	Aug. 20-21	E.W.	32
20	Aug. 24	N.S.	32

In the case of three plots, the setting of the cylinder was such that the points were too bunched to permit a determination of the phase of the component in question. It is also possible that the high value of  $47^\circ$  for Plot No. 17 should not have been included owing to the bunching of the points. The remaining values for the phase of the component which we have ascribed to the earth's field, with the exception of the value found on Plot No. 12 are constant at least nearly within the experimental error. We have no satisfactory explanation for the result found on Plot No. 12, which is apparently definitely given by the data. It is interesting to note that Plot No. 13 for data taken on the same dates also has a low phase angle, and it is possible that some consistent error was made in the phase readings taken on those dates.

The mean value for the phase of the component due to the earth's field is  $30.2^\circ$ , with an average deviation from the mean of  $\pm 4.0^\circ$  and a probable error of  $\pm 1.0^\circ$ .

It is evident that this phase should be related to the lag of the current behind the electromotive force in the cylinder, since the lag in other circuits is negligible. The protractor scale was set on the earth inductor frame so that the maximum electromotive force in the earth inductor came at approximately  $0^\circ$ , while the maximum electromotive force in the cylinder produced by cutting the earth's field must come at the center of the stroke. Hence allowing for the change in phase on passing through the transformer involved, it is evident that our results give a lag of current in the longitudinal circuit around the cylinder of  $59.8^\circ$  behind the electromotive force.

Of course no exact calculation can be made of the expected lag in this longitudinal circuit, because of its complicated shape and somewhat uncertain dimensions. Nevertheless, if we take this longitudinal circuit as being a copper rectangle<sup>1</sup> having an outside length of  $9 \frac{1}{8}$  inches, outside width of 4 inches, and inside dimensions 1 inch less (the dimensions of the cylinder), and ascribe a thickness

---

<sup>1</sup>The end plates were phosphor bronze.

of 3 inches to the rectangle we obtain a calculated phase lag of  $60^\circ$  as compared with the experimental value of  $59.8^\circ$ . Since the thickness ascribed to the longitudinal circuit seems a reasonable one, we may regard the theory and data as being in approximate agreement.

The sense of the electromotive force introduced by setting the cylinder in a given direction away from parallelism to the earth's field and tipping the coil in a given direction, was also found to be that which would be predicted on the basis of the theory.

20. Magnitude of the Component of the Electromotive Force Due to the Earth's Field. \* It is also possible to investigate the magnitude of the electromotive force introduced by the earth's field and see if this is in agreement with the theory. For the small angles involved, this magnitude should be proportional both to the angle of setting of the cylinder in a given plane away from parallelism to the earth's field, and proportional to the tip of the coil away from parallelism to the cylinder in the plane at right angles to the above. The upper lines in our Plots Nos. 1-20 are drawn so that the slopes of these lines give, each for its own setting of the cylinder, the ratio of the component of electromotive force in question to the angle of tip of the coil and hence can be used to test the above prediction. This has been done in the following two plots Nos. 21 and 22, where the abscissae are the angular settings of the cylinder away from normal and the ordinates are the slopes ( $\tan \theta$ ) of the upper lines in Plots Nos. 1-20 measured away from the vertical. Although the data are not very well spaced since they were not taken to test the point in question, nevertheless it will be seen that the points do fall on straight lines as would be predicted by the theory. Furthermore these two lines have nearly the same slopes, namely  $38^\circ$  and  $40^\circ$  as would be predicted.

---

<sup>1</sup>The calculations were made with the help of formula 87 Bull. Bur. Standards, 5, 54 (1908-9).



We may also investigate to see if the absolute magnitude of the electromotive force which we believe to be introduced by the earth's field has a reasonable value.

From Plots Nos. 21 and 22, we find that a setting of the cylinder, 0.01 radian from parallel with the earth's field, corresponds to an average value of  $\tan \theta$  of 4.05. Using this figure, we then find from the scale of Plots Nos. 1-20 that the above setting of the cylinder combined with a tip of the coil of 0.01 radian, at right angles to that of the cylinder, would give a slide wire reading of 0.0802 for the component of electromotive force introduced by cutting the earth's field. Finally the angle of oscillation of the cylinder in the effect runs was 0.326 radians (see Section 25).

On the other hand in the calibration of the cylinder we find that a slide wire setting of 0.8618 corresponds to an angle of transverse oscillation of  $4.09 \times 10^{-4}$  radians (see Section 25).

Hence if we make the very rough assumption that the transformer coupling is the same for the two different circuits involved, we might expect the two slide wire readings to stand roughly in the ratio

$$\frac{S_1}{S_2} = 0.01 \times 0.01 \frac{\theta_1 A_1 Z_2}{\theta_2 A_2 Z_1} \quad (A)$$

where  $\theta$ ,  $A$  and  $Z$  represent angle of oscillation, area of circuit and impedance of circuit. The left-hand side of equation (A) has the value 0.09. And substituting a value of  $Z_1$  calculated for the same circuit assumed above in accounting for the phase, and for  $Z_2$  a value calculated from the cylindrical shape of the circuit involved, we obtain for the right-hand side the value 0.04. This is not a close check and yet seems sufficient in view of the assumptions that had to be made to indicate the general reasonableness of our picture.

21. Conclusions as to the Effect of Earth's Field. - In conclusion it would seem as if our theory as to the part played by the earth's field in producing electromotive forces in the moving cylinder had been satisfactorily substantiated. In the first place practically all the measurements, although taken as they had to be under conditions where there are large errors of observation, lead to consistent results. In the second place, the analysis of the data shows that the component electromotive force in question has sense and phase in agreement with the theory, and a magnitude that depends on angle of setting of cylinder, angle of tip of coil and velocity of motion through the earth's field as would be predicted.

At first sight it may seem that the elaboration and detail with which we have studied the effect of the earth's field was not justified, since there is of course nothing new in the theory of the electromotive forces and currents produced in a conductor moving in a magnetic field. Nevertheless, we have felt that a complete study of the effect in our actual cylinder was necessary, since our chief interest is the very small residual electromotive force remaining when cylinder and coil are in alignment. In the first place, we must know how much this electromotive force may be affected by lack of exact alignment, and in the second place, we must assure ourselves if possible that the total electromotive force present in the cylinder does really consist of only two components, one due to cutting the earth's field and the other due to the inertia of the electrons. It would seem from the foregoing analysis that this is substantially true although there are minor discrepancies which will be more fully discussed in a later section.

We may now proceed to a discussion of the component of main interest, namely the electromotive force produced by the inertia of the electrons.

#### IV. Elementary Theory of the Inertia Effect

22. The Electromotive Force in a Stationary Conductor. - In order to discuss intelligently the measurements of the electromotive force due to the inertia of the electric carrier, it seems desirable to present first an elementary theory of the expected effect.

Consider a stationary circular conductor of length  $2\pi r$  and cross section  $a^2$ <sup>1</sup> and assume the conductor to be entirely rigid, neutral atoms and positive ions being held definitely in position in the atomic frame work, but provided with  $n$  mobile electrons per unit volume having the mass  $m$ <sup>2</sup> and charge  $-e$ . If an external electromotive force  $E$  is applied to this circuit, for example by changing the magnetic flux through it, then the force acting on each electron in the direction around the circuit will evidently be  $-e(E - L_g dI/dt)/2\pi r$ , where the first part is due to the external electromotive force and the second part, depending on current  $I$  and inductance  $L_g$ , is due to the variation in flux through the circuit produced by the changing current in the conductor itself. We may now equate this force on the electron to the rate of change of its momentum plus the resistance which the electron experiences because of its motion through the conductor, giving us

$$-\frac{eE}{2\pi r} + \frac{e}{2\pi r} L_g \frac{dI}{dt} = m \frac{dv}{dt} + \alpha v \quad (1)$$

where the resistance to the motion of the electron is set proportional to the velocity  $v$ , the proportionality constant being designated by  $\alpha$ .

In interpreting this equation, it should be noted that  $v$  is the excess velocity which the electrons acquire in the direction of the electric force and this is measured with respect to the stationary coordinates with respect to which the conductor itself is at rest. It should also be noted that  $L_g$  is merely the coefficient connecting

<sup>1</sup>The cross section is taken small compared with the length.

<sup>2</sup>The mass  $m$  is regarded as concentrated close to the charge.

change of current with change of flux, and hence is the inductance of the circuit as would be calculated from the geometrical shape of the circuit. As we shall presently see it differs by a very small and usually negligible quantity from the measured inductance.

We can eliminate the velocity  $v$  from equation (1), through its relation to the current according to the obvious equation

$$I = - n e a v \quad (2)$$

Substituting and solving for the electromotive force, we obtain

$$E = \left( \frac{2\pi r m}{n e^2 a} + L_g \right) \frac{dI}{dt} + \frac{2\pi r \alpha}{n e^2 a} I \quad (3)$$

Comparing with the usual expression for electromotive force

$$E = L \frac{dI}{dt} + IR \quad (4)$$

we see that  $(2\pi r \alpha)/(n e^2 a)$  is merely the kinetic theory expression for the resistance of a circuit of ~~unit~~ <sup>a</sup> cross section and length  $2\pi r$ . While  $(2\pi r m)/(n e^2 a)$  is a small correction which must be added to the calculated inductance  $L_g$  to obtain the total experimental inductance  $L$ . Since no discrepancies have ever been observed in ordinary measurements between calculated and experimental inductance, we conclude that the number of conducting electrons per cubic centimeter  $n$  is a large quantity. (Compare Lorentz, The Theory of Electrons, Teubner 1909 Note 17). This small corrective term which can usually be neglected is, however, of prime importance in determining the effect in which we are interested.

23. The Effective Electromotive Force in an Accelerated Conductor. - Consider now the same circular conductor, not subject to any external electromotive force, but moving around the axis with a tangential velocity  $V$  and acceleration  $dV/dt$ . We may now set up a similar expression to equation (1) above, for the force acting on an electron, namely

$$\frac{e}{2\pi r} L_g \frac{dI}{dt} = m \frac{dv}{dt} + \alpha (v - V) \quad (5)$$

where the term containing the external electromotive force  $E$  is omitted, since this is taken as zero, and the resistance to the motion of the electrons is set, as is obvious, proportional to the relative velocity of electrons and conductor  $(v - V)$ . The velocities  $v$  and  $V$  are of course both measured with respect to stationary coordinates.

The velocities  $v$  and  $V$  can also be eliminated from equation (5), by means of the evident expression for current

$$I = -nea(v - V) \quad (6)$$

Substituting in (5) and transforming, we obtain

$$2\pi r \frac{m}{e} \frac{dV}{dt} = \left( \frac{2\pi r m}{ne^2 a} + L_g \right) \frac{dI}{dt} + \frac{2\pi r \alpha}{ne^2 a} I \quad (7)$$

We thus see, by comparison with equation (3), that the acceleration of the conductor may be regarded as producing an effective electromotive force

$$E_e = 2\pi r \frac{m}{e} \frac{dV}{dt} \quad (8)$$

which is proportional to and in phase with the acceleration. The primary purpose of our work is of course to compare this predicted expression for the effective electromotive force with that found experimentally.

The above derivation for the effective electromotive force produced by acceleration is of course an elementary one, containing simplifications some of which may not be completely justified. In the first place, the theory tacitly assumes that the mass of an electron can be regarded as a definite quantity  $m$  rigidly bound to the charge  $-e$ , and distinguished without ambiguity from other electromagnetic mass within the conductor, as well as from the mass associated with the overlapping magnetic fields which surround the conductor and determine the flux through the circuit. In the second place, possible forces acting between the conduction electrons and the body of the conductor, other than the quasi-frictional force which has been set proportional to the velocity, have been neglected. Finally the electrical

properties of the accelerated conductor have been regarded as unaffected by the elastic strains which necessarily accompany the acceleration. We have the feeling however, that these simplifying assumptions are of a character which would not seriously affect the result. A further discussion of the matters will be given later.

24. Comparison of Electromotive Forces Obtained in Effect and Calibration

Runs. - In order to test equation (8) with the help of the experimental data obtained in the effect and calibration runs, let us first consider in the case of the effect runs, a current sheet in our oscillating cylinder, having the radius  $r$ , and hence the instantaneous acceleration

$$\frac{dV}{dt} = 4\pi^2 \nu^2 \Theta_e r \sin 2\pi (\nu t + S) \quad (9)$$

where  $\nu$  is the frequency of the harmonic oscillation and  $\Theta_e$  is half the angular amplitude of oscillation. Substituting in equation (8) we obtain

$$E_e = 8\pi^2 \nu^2 r^2 \left(\frac{M}{e}\right) \Theta_e \sin 2\pi (\nu t + S) \quad (10)$$

Let us now compare this expression for the expected electromotive force in the effect runs with the known electromotive force in the calibration runs. For the small angles of oscillation used in these latter runs the flux through the circuit is proportional to the area of the circuit  $\pi r^2$ , the strength of the earth's magnetic field  $H$ , and the angle through which the circuit has been turned away from parallelism with the field. Hence for harmonic oscillations of frequency the electromotive force in the calibration experiments is

$$E_c = 2\pi^2 \nu r^2 H \Theta_c \sin 2\pi (\nu t + \gamma) \quad (11)$$

where  $\Theta_c$  is the half amplitude of oscillation in calibration.

Considering first merely the amplitudes of the two electromotive forces, we obtain by division

$$\frac{(E_e)_{\max}}{(E_c)_{\max}} = \frac{4\pi v}{H} \frac{m}{e} \frac{\Theta_e}{\Theta_c} \quad (12)$$

It will be noted that the radius  $r$  of the particular current sheet under consideration has very fortunately dropped out of the expression, and hence the ratio

$(E_e)_{\max} / (E_c)_{\max}$  can be taken as the ratio of the total electromotive forces in the effect and calibration runs, and put equal to the ratio of the slide wire readings,

$S_e / S_c$  necessary for balance. Making this substitution and solving for the ratio of the mass of the electron to its charge, we obtain

$$\frac{m}{e} = \frac{H}{4\pi v} \frac{S_e}{S_c} \frac{\Theta_c}{\Theta_e} \quad (13)$$

as the expected expression correlating the amplitudes of the two electromotive forces which are proportional to the slide wire readings  $S_e$  and  $S_c$ .

We must also consider the expected correlation of the phases of the electromotive forces obtained in the effect and calibration runs. Evidently the maximum electromotive force in the effect runs should occur at the end of the stroke where the acceleration is a maximum, while the maximum electromotive force in the calibration runs occurs at the center of the stroke where the rate of change of flux is a maximum. For accuracy of measurement, however, the angle of the earth inductor must in both cases be read at the center of the stroke, and hence we should expect the two phase readings to differ by  $90^\circ$ , the direction of the difference being determinable from the directions of the two motions and the direction of the earth's field.

## V. Experimental Results on Amplitude and Phase

25. Results from Runs of July 23 to August 24, 1925. - The experiments already described, for which data are given in Plots Nos. 1-20, were primarily planned for studying the effect of the earth's field and not for getting an accurate measurement of the electromotive force due to the inertia effect, and an accurate control of amplitude of oscillation, frequency of oscillation and temperature was not kept. Nevertheless, the data are good enough to give approximately correct results which will be valuable for comparison with the better results presented in the next section.

During the effect runs in question, the frequency of oscillation  $\nu$  varied for different runs, owing to difficulties with the tachometer, from 19.9 to 20.3 per second with a fair average of 20.1 per second. The half amplitude of oscillation also varied somewhat, owing to changes in connecting rods and conditions of operation, from  $18.4^\circ$  to  $19.0^\circ$  with a fair average at  $18.7^\circ$ , giving us  $\Theta_e = 0.326$  radians. The slide wire reading for the component of electromotive force left when the coil was parallel to the cylinder could be obtained perhaps most accurately from Plots 1-20, by projection from the point of intersection of the upper line with the axis to the lower line. It seems sufficient for our purposes, however, to take the average slide wire reading for all runs where the cylinder and coil were parallel. There were 53 such runs, giving an average slide wire setting  $S_e$  of 0.0142, having a mean deviation of 0.0023 and a probable error of 0.0003. The average phase reading at center of stroke moving east was  $111.5^\circ$  with a mean deviation of  $15.8^\circ$  and a probable error of  $2.2^\circ$ .

In the calibration runs the frequency of oscillation was 19.9 per second, not sufficiently different from 20.1 so that we need allow for it (see Section 38). Three runs were made under the same conditions with the following readings for the amplitude of oscillation as given by the total width of the light band on the ground glass scale,



corrected for the width of the filament image, 45.6, 45.6, 45.3; average 45.5 mm., giving for the half amplitude of oscillation  $\Theta_c = 4.09 \times 10^{-4}$  radians. The slide wire settings were 0.8621, 0.8605, 0.8628, average 0.8618. The phase readings at the center of stroke moving up were 34, 34, 33.5, average 33.8°.

The horizontal component, declination and dip of the earth's field was kindly determined for us by Mr. Wallace M. Hill of the Coast and Geodetic Survey at the location in question in the spring of 1923. Since that time and previous to the summer of 1925 a nearby street car line was discontinued, which Mr. Hill believed to have some effect on the results. Nevertheless, since Mr. Hill's determination at another nearby station several times as far from the street car line gave nearly the same results we can use them for our calculations. The strength of the horizontal component was 0.26753 and the dip  $59^\circ 25'$ , giving us  $H = 0.52581$  gauss.

Substituting now in equation 13 for the ratio of mass to charge, we obtain

$$\frac{m}{e} = \frac{H}{4\pi V} \frac{S_e}{S_c} \frac{\Theta_c}{\Theta_e} = \frac{0.5258}{4\pi \times 20.1} \frac{0.0142}{0.8618} \frac{4.09 \times 10^{-4}}{0.326}$$

$$= 4.30 \times 10^{-8} \text{ grams per abcoulomb,}$$

as compared with the value obtained in free space from cathode ray deflections of  $5.66 \times 10^{-8}$  grams per abcoulomb.

Coming now to the phase of the effect as compared with the phase in calibration, we find, taking account of the connections and direction of motion in the earth's field, that the average phase of the effect electromotive force lags  $12.3^\circ$  behind the acceleration of the cylinder.

We thus find that these preliminary experiments give an electromotive force with an amplitude 24% less than that predicted on the basis of the elementary theory and a phase lagging  $12.3^\circ$  behind the predicted. Both these deviations are greater than the "probable error" of the measurements.

26. Results from Runs of February 18 to March 5, 1926. - In the light of these results, additional more carefully controlled experiments were made in the winter of 1926, for the express purpose of getting the best possible values for the amplitude and phase of the effect electromotive force. Several improvements in the apparatus or method were also introduced at this time.

In work preliminary to the measurements which we are about to discuss a new source of possible accidental electromotive force was discovered. The work was performed at a time of considerable temperature fluctuation throughout the day, and very irregular results were found when the torsion rods changed length so as to pull the cylinder hard against the upper or lower thrust bearings. To obviate this the shoulders on the end plates of the cylinder were now turned down so that there was hereafter no contact between end plates of the bearings. This possible source of trouble may account for certain irregularities in the summer work of 1925. (In the Washington work there were no thrust bearings.) We are inclined to think that excessive friction at the thrust bearings may lead to the flow of alternating current through the cylinder and back again through the bed plate, a certain portion of the flux produced being picked up by the coil.

A new method was also installed for setting the coil parallel to the cylinder. The taper gauge, which had previously been used for this purpose, was not entirely satisfactory, since the coil, being hung from above, springs away when the gauge is inserted in the annular space between it and the cylinder. Hence split centering plates were now provided for the two ends of the coil, with pins fitting into holes in brass pieces on the coil, and arranged to clamp on the bearing bushings which were themselves turned true with the shaft. These plates were henceforth used to align the coil parallel with the cylinder before each set of runs, any deviation from alignment after they were removed being adjusted with the help of the telescopes, scales and mirrors already described.

The runs in question were made with the cylinder in its normal position, since this gave the smoothest operating conditions. Since this normal position is not quite parallel with the earth's field, it was quite important that the axis of the coil should be exactly parallel with the cylinder. Furthermore, it is of course the "electrical" axis rather than the mechanical axis, if they differ, which must be considered. To allow for this, an approximately equal number of runs were made with the coil in its usual position and then rotated around the cylinder through approximately  $180^\circ$ , a procedure which would change by  $180^\circ$  the phase of any electromotive force introduced from the longitudinal circuit in the cylinder. As will be seen from the results, however, there was no appreciable change in effect due to this rotation.

Forty-nine effect runs were made in all, with the coil in its usual and reverse positions, taken in eight groups on different half days. Since the readings taken on a given half day often check among themselves considerably better than they do with those taken on another half day, a fair idea of the results would not be given by the final mean and its probable error. Hence we present in Table II a summary which gives the mean values of slide wire reading and phase reading for each group of runs. It will be noted specially in the case of the phase readings that the means for the different groups differ by an amount which is almost certainly greater than could be accounted for on the mere basis of errors of observation.

Table II  
Effect Runs. February 18 to February 27, 1926

Date	Temp.*	Position of coil	No. of runs	Mean slide wire reading	Av. deviation from mean	Mean phase reading	Av. deviation from mean
Feb. 18, P.M.	16.3°	Reverse	4	0.0154	± 0.0008	130.4	± 1.7
Feb. 24, A.M.	12.5°	Reverse	9	0.0149	± 0.0008	99.7	± 2.8
Feb. 25, A.M.	12.0°	Usual	8	0.0141	± 0.0007	113.7	± 1.2
Feb. 25, A.M.	14.5°	Reverse	3	0.0162	± 0.0006	105.7	± 2.1
Feb. 26, A.M.	13.7°	Reverse	8	0.0143	± 0.0002	114.8	± 1.9
Feb. 26, A.M.	16.9°	Usual	3	0.0155	± 0.0002	111.7	± 0.6
Feb. 26, P.M.	20.0°	Usual	4	0.0136	± 0.0005	121.8	± 2.3
Feb. 27, A.M.	14.0°	Usual	10	0.0141	± 0.0006	111.0	± 5.1

\*The temperature was measured near the beginning of each set of runs by a thermometer inserted in a hole in the metal bed plate.

We are led to conclude from the foregoing that the measurements are still affected to a small extent by some variable factor which has not yet been removed. If, however, this variable factor is itself accidental in character, changing from one group of runs to another in accordance with the laws of chance, the final means with their probable errors, calculated by treating the original means for each group as separate observations should be significant.

Proceeding on this basis we obtain for the mean slide wire reading  $S_c$ , 0.0148 with an average deviation from the mean of  $\pm 0.007$  and a probable error of  $\pm 0.003$ ; and for the mean phase reading,  $112.4^\circ$  with an average deviation from the mean of  $\pm 5.3^\circ$  and a probable error  $\pm 1.9^\circ$ . The frequency  $\nu$  in these runs was 19.8 per second, and the half amplitude of oscillation  $13.8^\circ$  giving us  $\theta_c = 0.328$  radians.

Eight new calibration runs were also made at the close of the effect runs, on Feb. 28, March 1, and March 5, the temperature ranging from  $14.5$  to  $20.5^\circ$ . The half amplitude of oscillation  $\theta_c$  was  $4.47 \times 10^{-4}$  radians, the mean slide wire reading was 0.9309 with an average deviation from the mean of 0.0054 and a probable error of 0.0019. The mean phase reading was  $32.4^\circ$  with an average deviation of  $0.8^\circ$  and a probable error of  $0.3^\circ$ .

Substituting now again in equation 13 for the ratio of mass to charge we obtain

$$\frac{m}{e} = \frac{H}{4\pi\nu} \frac{S_e}{S_c} \frac{\theta_c}{\theta_e} = \frac{0.5258}{4\pi \times 19.8} \frac{0.0148}{0.9309} \frac{4.47 \times 10^{-4}}{0.328}$$

$$= 4.58 \times 10^{-8} \text{ grams per abcoulomb}$$

as against  $4.30 \times 10^{-8}$  from the earlier runs, and  $5.66 \times 10^{-8}$  for  $\frac{m}{e}$  in free space, a deviation from the latter figure of 19%.

We also find in these runs a lag of the average phase of the effect electromotive force behind the acceleration of the cylinder of  $10.0^\circ$ , as against  $12.3^\circ$  in the earlier runs.

It is evident that the deviations from the predicted values are still present in approximately the same amount.

## VI. Critique of the Experimental Work

The small deviations from the predicted magnitude and phase of the electromotive force produced by the inertia of the electrons make it important to criticize the experimental work in detail. If these deviations should be real it would be a matter of considerable significance. If, on the other hand, they are due to errors in the experimental method, we are merely interested in discovering their cause. A discussion of the experimental work and its difficulties is also of importance in suggesting improvements for the future. In what follows we shall present a large number of special tests and considerations that were made in investigating possible sources of error. We shall first consider some possible sources of error in the effect runs, and <sup>then</sup> ~~their~~ possibilities of error in the calibration runs.

27. Vibration of the Coil. - The most obvious possible cause of accidental electromotive forces would lie in vibration of the coil in the effect runs. We do not believe, however, that this is <sup>a</sup> ~~the~~ source of trouble. No change in the results accompanied the change from having the coil cradle mounted with rubber washers on the cement pier, to having it supported from an overhead truss which had no connection with the pier or building. Before this change was made vibration of the coil could some times be felt unless care was taken as to the period introduced by the elastic forces of the rubber washers. After the change no vibration whatever could be felt in the coil when the apparatus was running, and no blurring of the image of a scale, reflected from a mirror on the coil and viewed in a telescope, could be detected when the apparatus was started. Furthermore, with the amplifier on, and the apparatus stationary no effect could be detected when the coil support was hit in such a way as to give vertical vibrations which would be the only ones of a period as high as 20 cycles. Similarly hitting the torsion rods had no effect, and running the water motor with the connecting rod disconnected had no effect.

28. Play in Cylinder Bearings. - Another obvious source of error would arise from excessive play in the bearings which would permit a transverse oscillation of the cylinder. The bearings were, however, carefully scraped in from time to time and the play was probably less than 0.0001" after scraping and it is doubtful if the play ever became as much as 0.001". Referring to Plots Nos. 21 and 22, we may take the cylinder in its normal position as being  $1.32 \times 10^{-2}$  radians out of parallel with the field. Referring to the calibration runs, we can then calculate that the maximum electromotive force which could be produced by cutting the earth's field if the direction and frequency of motion were most favorable, by an oscillation of total amplitude of 0.0001" in each bearing would correspond to a slide wire reading of 0.00027 as compared with the reading 0.0148 produced by the effect itself. It seems possible that some error may arise from this cause, although it does not seem very probable that it seriously affects our final averages.

29. Asymmetry in Cylinder. - It seems possible that asymmetry in the cylinder might affect the results, for example an angular deviation between the axis of rotation and the axis of the cylinder, which would cause the cylinder to cut the earth's field when rotated. Of course care was taken to have the cylinder true with itself and its bearings. Nevertheless, some lack of symmetry somewhere in the oscillating system may be indicated by the results on Plots Nos. 18, 19 and 20, where the cylinder was rotated and clamped with different faces of the hexagonal torsion rods uppermost, and somewhat different results obtained. It is interesting to note, however, that the deviations appear smaller on Plot 20 than on 18 and 19, even though the cylinder was less nearly parallel to the earth's field. It is also important to note that such asymmetry can not be accounted for the deviations between the means in the final effect runs recorded in Table II, since all these runs were made

with the cylinder turned the same way. It is unfortunate that time did not permit a more thorough study of these matters. It is hard to estimate whether the final results are affected by this source of uncertainty. Nevertheless, most of the effect runs in the summer of 1925 were made with the cylinder turned northeast and those of 1926 with the cylinder southeast, and since there was no great difference in the results it would seem as if the effect were not an important one. (Note on Plot No. 20 that straining the torsion rod by setting the bottom clamp out of line had no appreciable effect.)

30. Effect of Centrifugal Force. - As already noted in the article describing the Washington experiments, the action of centrifugal force, in causing the cylinder to expand and contract with the velocity of rotation, would change the earth's flux through the circuit and thus introduce an electromotive force. This electromotive force is small, however, and has twice the period of the effect, and hence can be entirely neglected, since the galvanometer was found to have no sensitivity at twice the period.

31. Photographic Analysis of Motion in Effect Runs. - It is evident that our results could be seriously affected, especially the phase readings, if the actual motion of the cylinder does not correspond to that expected from the mechanism of the set up. For this reason arrangements were made to photograph the motion of the cylinder in the effect runs on a moving film, by a beam of light coming from a small lamp attached to the lower end plate of the cylinder. A mirror was also attached to the earth inductor in such a way as to produce a line across the curve at a known phase reading. Two experiments were made in this way. The curves obtained appeared, without making an actual harmonic analysis, to be pure sine waves and the photographic phase determinations agreed with the phase determinations made by our usual method within  $1.5^\circ$  and  $3.5^\circ$ , the deviations being in opposite directions for the two trials. We conclude that there is no appreciable error from the suggested source.



32. Effect of Direct Earthing of Cylinder. - The possibility that the results might be affected by electrostatic charges on the cylinder was tested. The cylinder was of course always earthed through the cement pier, but a special test in which direct earthing was made to the earthed binding post of the coil showed no change in balance.

33. Tests with Double Tie of Coil. - Special tests were made, when studying the effect of the earth's field, with the coil tipped out of alignment both in the north-south and east-west plane. No anomalous behavior resulted (see Plot No. 11).

34. Tests with Field from External Magnet. - Tests were made in the effect runs with the field from an external magnet showing similar effects to those produced by tipping the cylinder in the earth's field.

35. Tests with Laminated Cylinder. - A very large number of tests were made with a laminated cylinder, constructed from 18 copper rings mounted on a "micarta" core, and having total dimensions about the same as our regular cylinder. This construction would prevent the longitudinal flow of current around the cylinder, and it was <sup>w</sup>no<sub>^</sub> found, in agreement with what was expected, that tipping the coil in the effect runs produced no appreciable change in balance.

We had great hopes that this new cylinder, by eliminating the possibility of longitudinal flow of current, would afford a great improvement in the method. A long series of experiments showed, however, that it gave very unreliable results. Straining the torsion rods by pressing on them while running or changing the adjustment of the end clamps produced enormous changes in the electromotive force in the cylinder. We finally concluded that the interaction between the insulating material and the copper rings may have been the source of the disturbing electromotive force. The impression was also gained that this disturbance was more likely to increase than decrease the electromotive force. This may account for the large values of  $m/e$  obtained in the Berkeley experiments.

36. Effect of Possible Currents in Nearby Circuits. - Accidental al-

ternating currents of the right period in nearby circuits could of course affect the results. One such circuit was definitely found and eliminated. The current in this circuit apparently flowed along the main driving shaft of the apparatus through the main bearing with return through the cement base to the water motor. This current was greatly increased by adjustment so that there was large pressure on the lower bearing, and was permanently eliminated by introduction of insulation into the shaft.

A study was also made of the possibility of alternating current flowing through the connecting rod and back through the cement pier. This would have been a dangerous circuit, since the coupling with the coil would have been good. We found, however, no change in results when the circuit was broken by an insulating sleeve as part of the connecting rod. Indeed a portion of the runs made in the summer of 1925 were carried out with such a sleeve and a portion without, no apparent affect on the results accompanying this change.

Attention has also already been called to the erratic results which were obtained when the torsion rods changed length so as to produce pressure on the cylinder bearings. We were led by analogy with the circuit through the main shaft to ascribe these results to the flow of current lengthwise through the cylinder with return through the bed plate. When further work is carried out, it will be desirable to introduce insulation so as to eliminate the possibility of any such current. This was indeed done in some of our preliminary work, without producing any noticeable change, but this was at a time when our measurements were not carried out with their final refinement. We have, however, very direct evidence that this circuit was not affecting the bulk of our measurements, since it is evident that tipping the coil in the east-west plane would introduce far more coupling with this circuit than tipping it in the north-south plane, while Plots Nots. 21 and 22 show definitely that there was no such effect.

37. Behavior of Galvanometer as Affected by External Disturbances. - As already noted, the galvanometer was always in motion when connected with full amplification to the coil, because of external magnetic disturbances. These disturbances seemed to be of two kinds: a steady part which produced a widening of the bank and a discontinuous part which produced "kicks" or sudden greatly increased widenings which then died away. The steady part was evidently due to commercial circuits in the city, since it was analyzed and found to have the local frequency of 50 cycles. The cause of the kicks, which were more serious, is unknown. These troublesome effects were of different magnitude on different days, and indeed for nearly the whole of one day the steady widening was so wide as to be off scale, probably indicating a temporary leak in power lines. It was also quite impossible to work after the street lights were turned on, on a neighboring street, the circuit for which had a large uncompensated area. We do not believe that these disturbances have any systematic effect on the results, but merely decrease the precision of the individual measurements.

It is interesting to note that the electromotive forces introduced by these external causes are of course many times greater than those measured, the tuned galvanometer making it possible to pay attention almost solely to the electromotive force of interest.

Attempts were made to eliminate these disturbances. Electrostatic shielding gave no result. By electrical filters, and tuning, however, it was possible to eliminate the steady widening but not the more serious "kicks", and this elimination was not used, since it appeared to introduce a lag in the time of response to a change in slide wire setting. Magnetic shielding might reduce the disturbances, but its use would probably be complicated by local poles on the inside of the shield which would induce unknown currents in the moving cylinder.

35. Effect of Changing Frequency in Calibration. - A number of studies were made of the calibration process to see if everything was behaving as would be expected. An increase in the frequency of oscillation produced, as would be predicted, a moderate change in the slide wire setting for balance, owing to improved transformer action, the increased velocity of oscillation of the cylinder being compensated by the increased velocity of rotation of the earth inductor. There was also an appreciable change in phase owing to the dependence of the lag of current in the cylinder on frequency. This is illustrated by the following table, where the amplitudes of oscillation were nearly constant.

Table III

Tachometer Reading	Slide Wire Setting	Phase Reading
1000	0.765	35.8°
1200	0.816	31.0°
1400	0.901	26.8°

It is evident that these changes are not large enough to be of importance in the actual calibration runs where the frequency could be held practically at the desired point.

39. Effect of Amplitude of Calibration Oscillation. - It would of course have been very serious if for some reason the slide wire setting were not directly proportional to the electromotive force around the cylinder, since for accuracy of angular measurement in the calibration runs, the electromotive force had to be much larger than in the effect runs. This was tested by making calibration runs at high and low amplitudes as shown below.

Table IV

Amplitude	Slide Wire	Ratio
43.0	0.760	56.6
8.0	0.138	57.9

This gives a check within the large experimental error involved in measuring the small amplitude.

40. Effect of Changes in Alignment. - Small changes were found in the calibration runs to accompany deviations from careful alignment of coil with cylinder. They did not appear large enough to be serious.

41. Effect of Magnitude of Amplification. - In the calibration runs it was usual to work with a lower amplification than in the effect runs. It was found, however, that the balance was not changed by raising the amplification to that used in the effect runs.

42. Test of a Nearby Circuit in Calibration. - By inserting mica under the stirrup on the outer cylinder shaft in calibration, it was found that <sup>the</sup> circuit consisting of cylinder, torsion rod, cam support and cement pier had no effect on calibration.

43. Photographic Analysis of Motion in Calibration Runs. - Photographic analyses were also made of the motion of the cylinder in calibration in a manner similar to that used for the effect runs. The photographic phase determinations for two films agreed with the phase determinations made by our usual method within  $2.2^\circ$  and  $4.0^\circ$ , the deviations being in opposite directions. A harmonic analysis was also made of one of our curves, and gave the amplitude 40.3 for the fundamental as compared with 40.0 for the total amplitude.

44. Phase of Calibration Electromotive Force. - A check on the operation of the apparatus can be obtained by comparing the phase of the calibration electromotive force with that which can be predicted from a rough calculation of the lag of current behind electromotive force in the cylinder.

The average phase setting for the final calibration runs was  $32.4^\circ$ , which corresponds to a lag of current behind electromotive force in the normal circuit around the cylinder of  $57.6^\circ$ , while the phase lag calculated for this circuit was  $64^\circ$ .<sup>1</sup>

45. Conclusions as to Experimental Work. - An examination of the foregoing appears to give only two indications as to errors of any importance in the determination. In the first place as shown by Table II, the amplitudes and phases for the effect runs made on a given half day tend to check among themselves better than they do with those made on another half day under supposedly identical conditions. In the second place, there seems to be some small difference in amplitude and phase produced by rotating the cylinder around its axis to a new position. The cause of these two phenomena is as yet unknown. If, however, we can assume that the small accidental effect still operative is as likely to produce deviations in one direction as the other, our final means then show a small but definite difference between the amplitude and phase of the effect experimentally measured and that predicted by the elementary theory.

<sup>1</sup>The calculations were made with the help of formula (2) Bull. Bur. Standards, 18, 475 (1922-23).

## VII. Critique of the Theory

In view of the uncertainty as to the reality of the small deviations between experiment and the elementary theory, the time is not yet ripe for any elaborate critique of the theory. Some preliminary considerations, however, of the three simplifying assumptions made in the elementary derivation will be of interest.

46. Nature of the Mass Associated with the Carriers. - The total electromagnetic mass associated with the lines of force surrounding an electron in the body of a metal must be of a complicated nature, while our elementary derivation has taken the mass as rigidly bound to the charge and the same as that associated with the spherical field surrounding an electron in free space. A complete analysis of the distribution of electromagnetic mass in <sup>the interior of</sup> a metal, and the fraction of it that could be regarded as bound to the electrons at any given acceleration of the metal would be complicated, if not impossible in the absence of a more satisfactory picture of the interior of a metal than we now have. Nevertheless, it seems as if most of the mass must be close to the center of the electron since that is where the lines of force are concentrated; and of course near to the center, the lines would presumably have the same spherical distribution as in free space. In addition it should be noted that down to distances of  $10^{-8}$  cm. from the positive charge, the Bohr-Sommerfeld theory of the hydrogen atom shows that there certainly is no great error in taking the mass as bound to the electron and the same magnitude as in free space.<sup>1</sup>

<sup>1</sup>Note in this connection, Bronstein, Zeits. f. Physik, 35, 863 (1926).

47. Forces on the Electron. - Our elementary deduction was obtained by equating the rate of increase in the momentum of the electrons to the forces acting on them. The only forces considered were due either to the change in flux through the circuit or to the "frictional" resistance of the conductor to the motion of the electrons, which was taken proportional to the relative velocity of electrons and conductor. It is important to point out, however, that no change would result from the inclusion of possible additive corrective terms, proportional to any function of the relative velocity<sup>1</sup>. The reason for this is that such terms would finally appear both in equations (3) and (7) as the same functions of the current  $I$  and hence would balance out.

Corrective terms dependent not on some function of the relative velocity but on a function of the velocity referred to the external stationary coordinates would not balance out.

48. The Effect of Torsional Strains. - Our elementary derivation treated the conductor as a rigid system unaffected by the torsional strains set up by oscillation. If the resistance should change periodically by an appreciable amount with the changing strains, or if the strains themselves, in the absence of acceleration, should produce electromotive forces, the analysis would have to be modified. These possible effects would presumably be small. Further on this point we can not now say.

To summarize the status of the theory, it would seem as if there were some uncertainties in the elementary deduction which would be worthy of further investigation. It does not seem probable, however, that improvements in the theory would change the order of magnitude of the predicted results. They might, however, be sufficient to account for small discrepancies between the elementary deduction and the experimental results of the order of magnitude that we have found.

<sup>1</sup>This includes the relative acceleration or higher derivatives, and quantities such as  $x-X$  which can be obtained from  $v-V$  by integration.



### VIII. Conclusion

In conclusion, we believe that our present experiments demonstrate far more satisfactorily than ever before the actual existence of an electromotive force in an accelerated metallic conductor due to the inertia of the electrons which conduct the current.

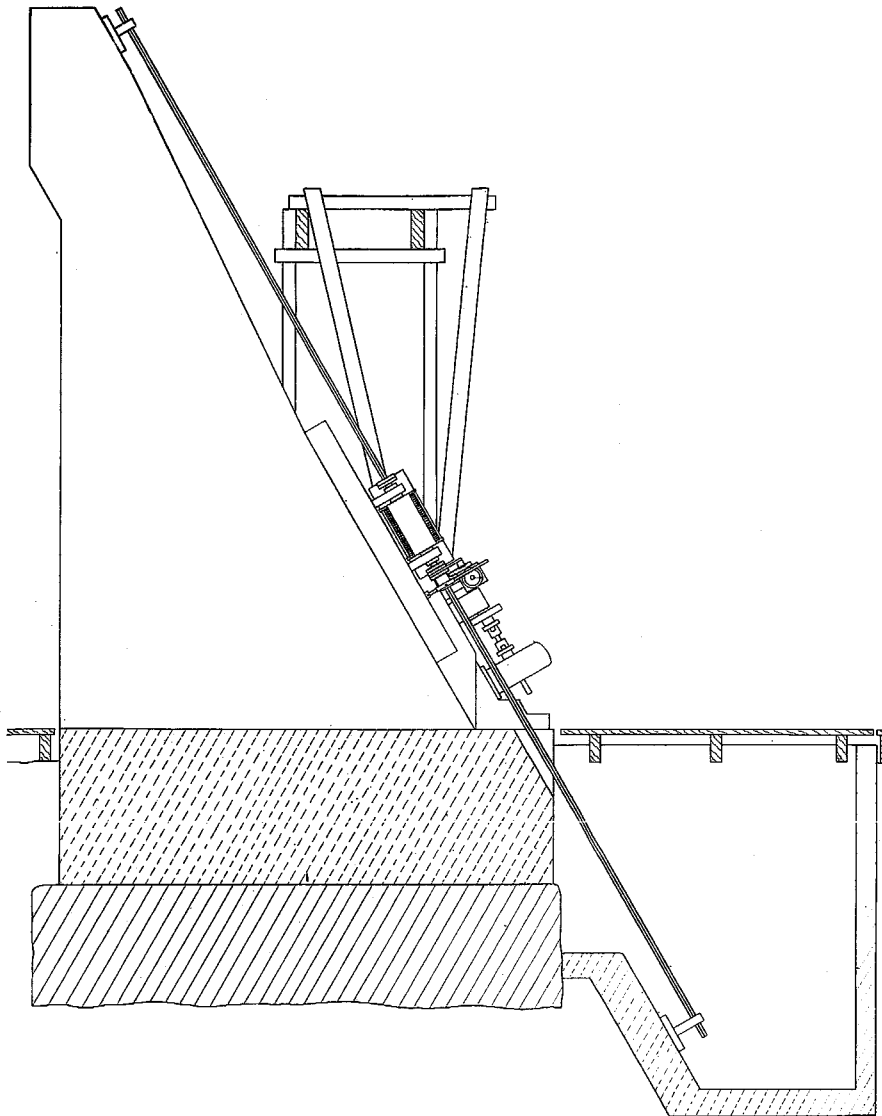
The average magnitude of this electromotive force was found to be 19% less than that predicted by an elementary theory which assumed the effective mass of the electrons the same as in free space; and the average phase of the electromotive force lagged  $10^\circ$  behind the acceleration, instead of agreeing with it as predicted by this elementary theory. These deviations from the predictions of the elementary theory were considerably greater than the probable error of the results. It could not be concluded from the data, however, that the deviations were necessarily greater than the actual error in the results. In addition no precise estimate was available as to the changes in the predicted values which might result from a more complete theory.

In the experiments of Tolman and Stewart, the electromotive force was found to have a value 15% greater than that predicted by the elementary theory. This may have been due to interaction between the metal wire and its insulation, since in the present work we have discovered apparent effects of this kind. On the other hand, the effective mass acting when the conductor was brought to rest may actually be greater than under the present conditions where the frequency of oscillation was twenty cycles. The experiments of Tolman, Karrer and Guernsey made at twenty cycles gave a value of the electromotive force 8% lower than the predicted, but the results are not as trustworthy as the present ones.

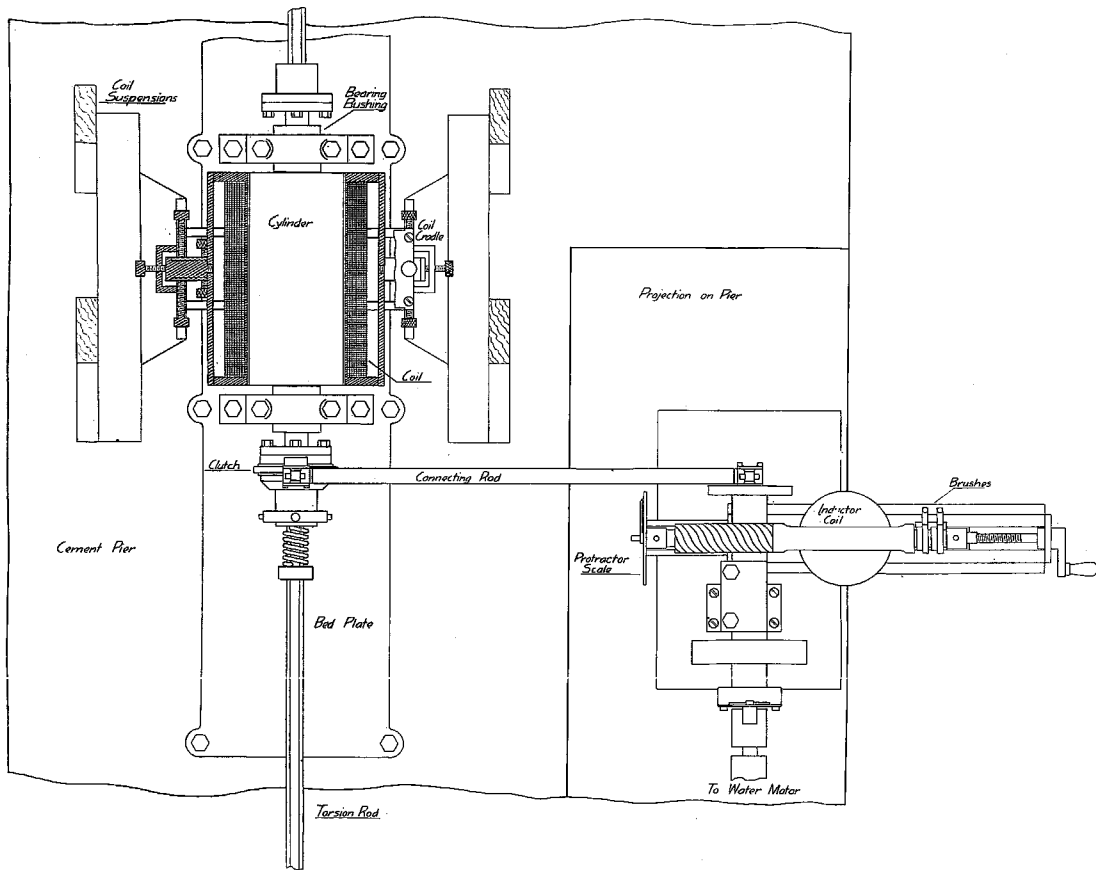
It would seem that further experimental and theoretical work would both be desirable, and it is hoped that this may be done at this laboratory.

We desire to express our appreciation to the Norman Bridge Laboratory for the generous support which it gave to this expensive investigation, and to give our thanks to Mr. Julius Pearson and his assistants for their skill in the construction of apparatus.

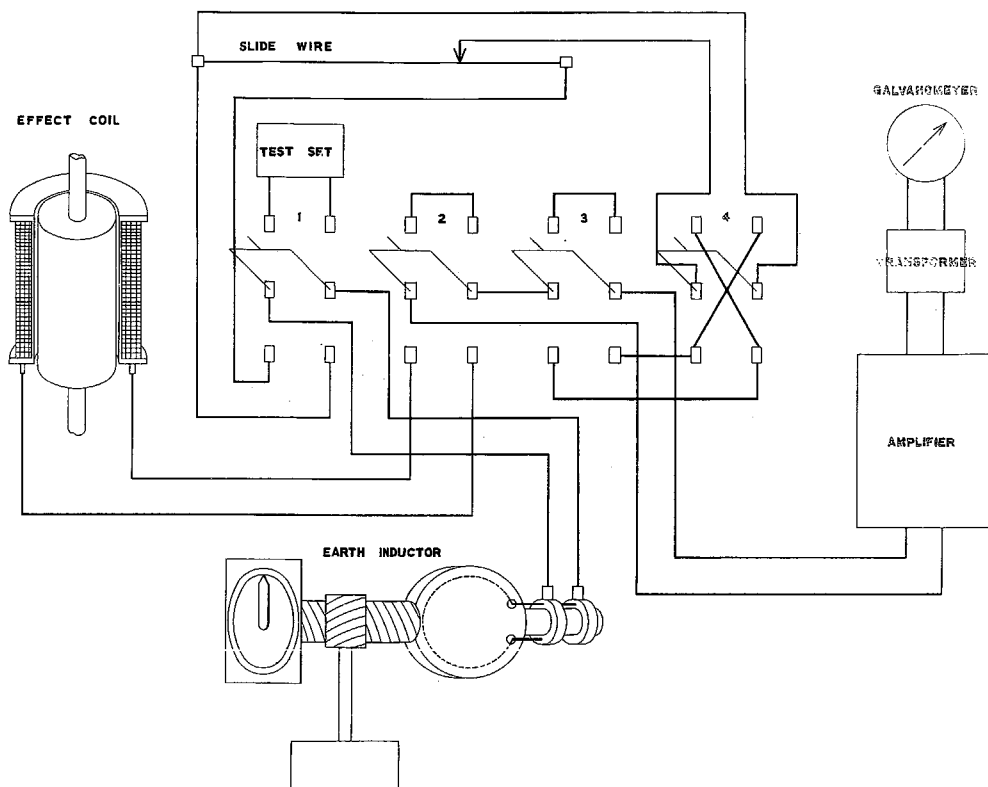
Norman Bridge Laboratory of Physics,  
California Institute of Technology,  
Pasadena, California.



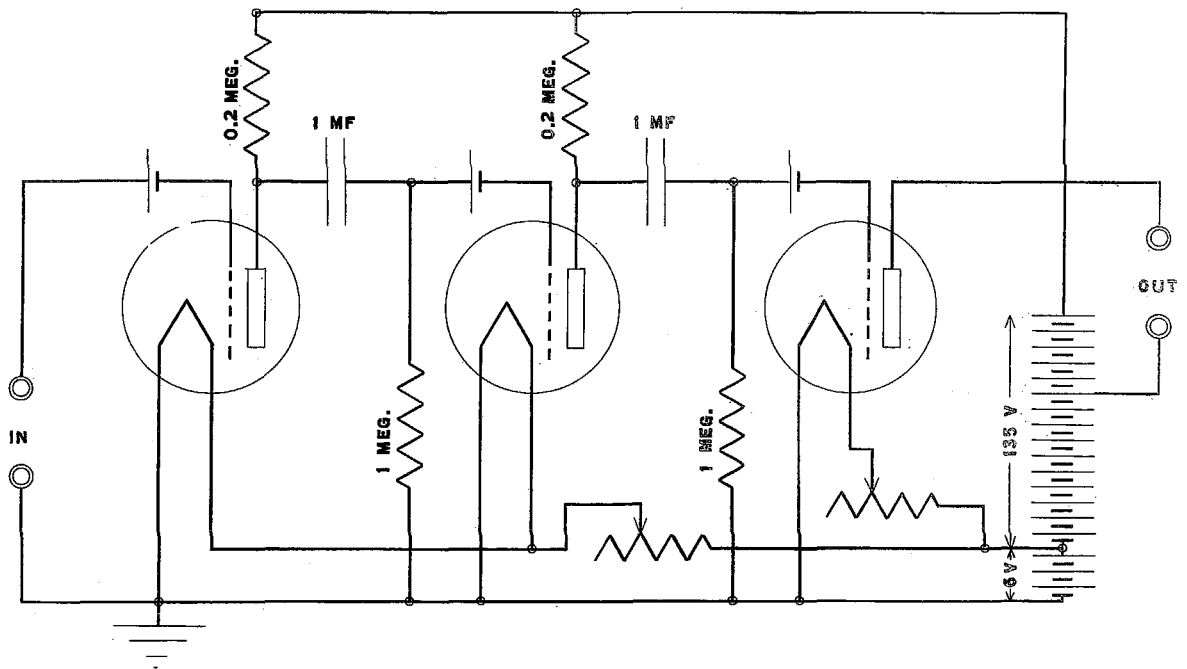
**Figure 1 Side View of Apparatus**



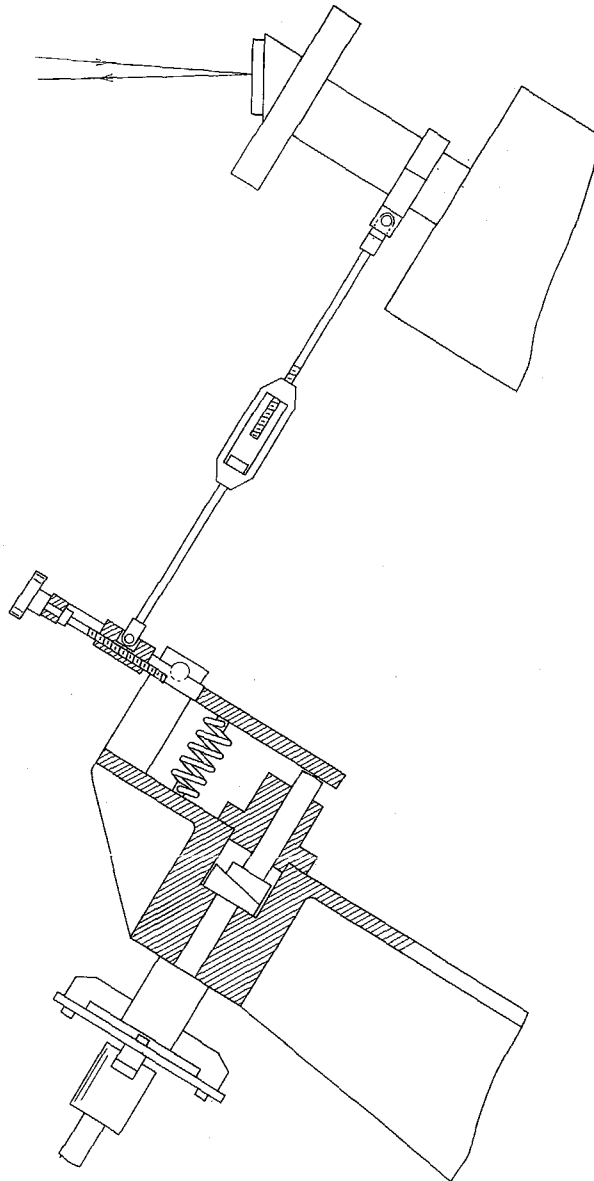
**Figure 2 Front View of Apparatus**



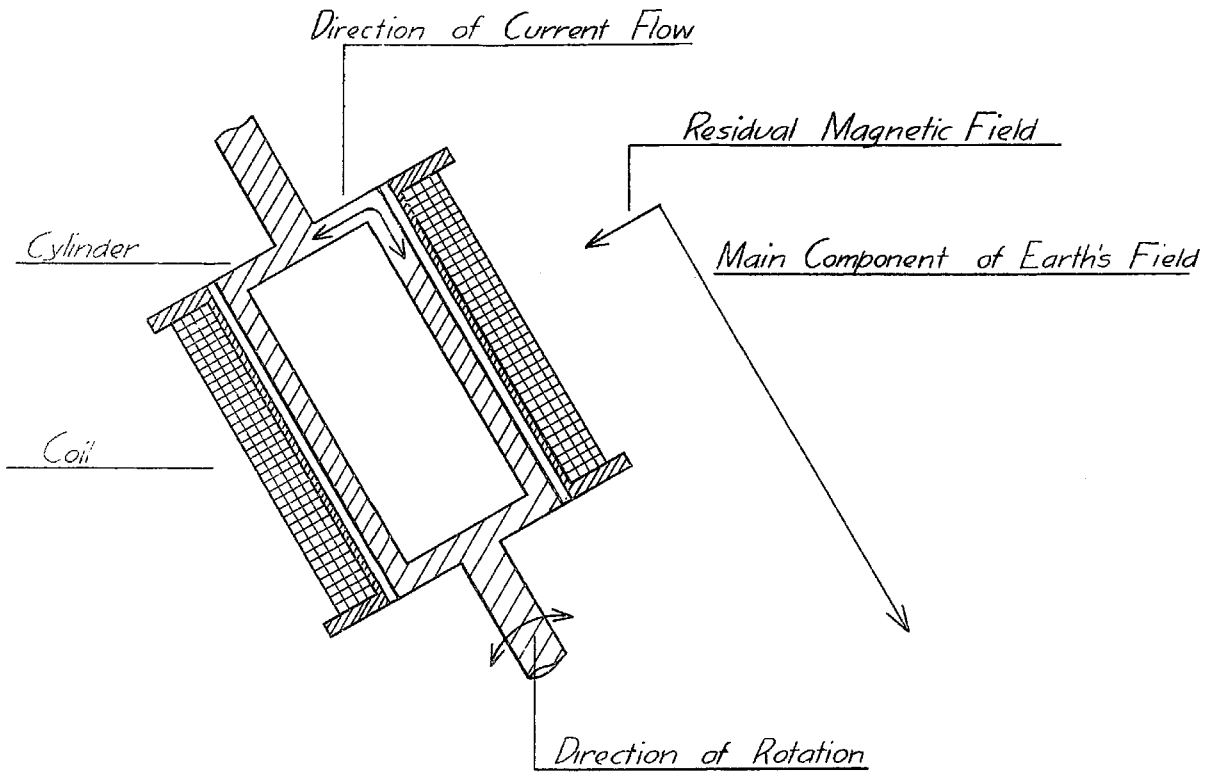
**Figure 3 Electrical Connections**



**Figure 4 Amplifier**

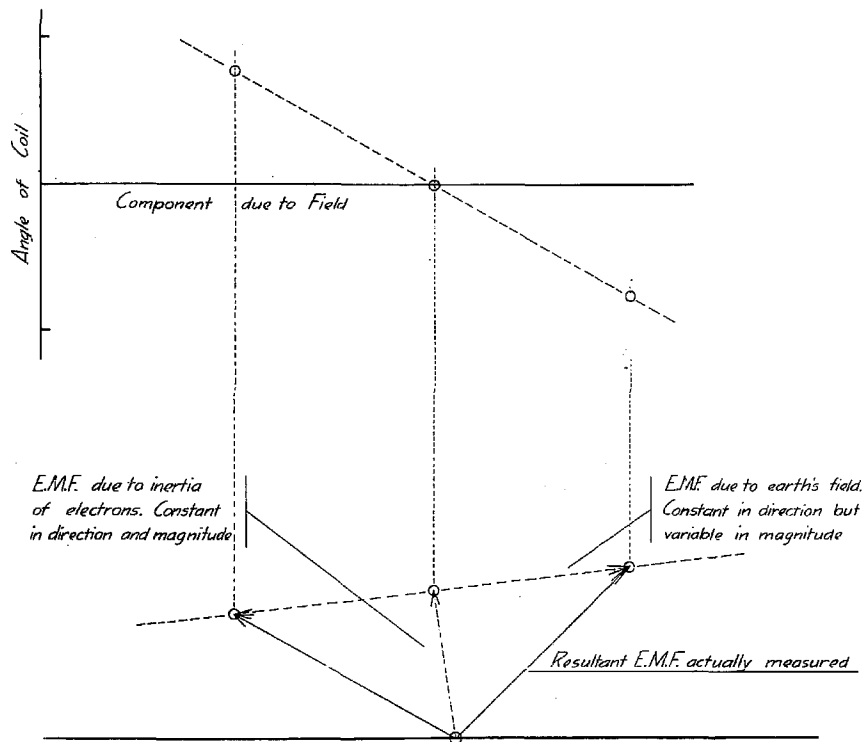


**Figure 5 Detail of Drive for Calibration**



**Figure 6 Diagram Illustrating Effect of Earth's Field**





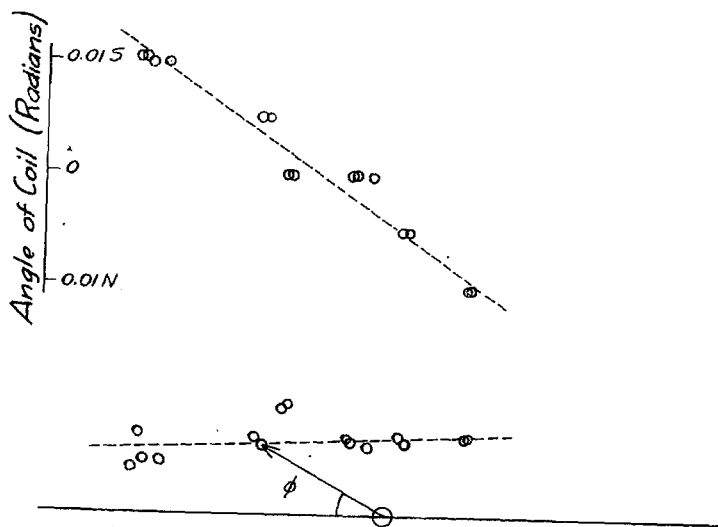
**Figure 7 Diagram Representing Electromotive Force as Sum of Two Vectors**

Plot No. 1

July 23 and 24, 1925

Axis of Cylinder Normal Position

Axis of Coil Tipped North and South

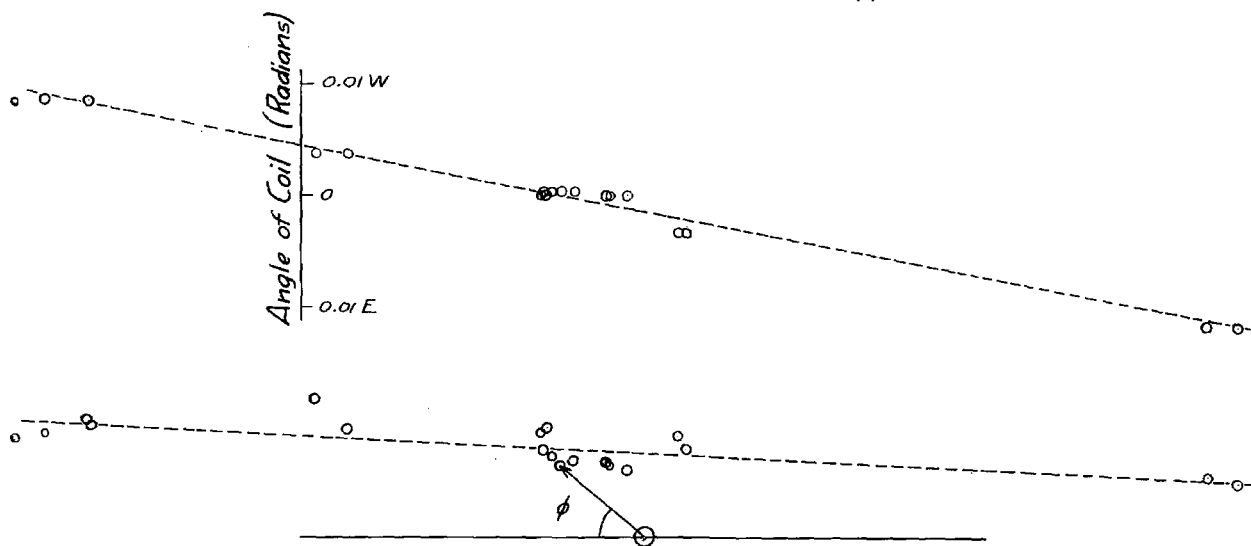


Plot No. 2

July 23 and 24, 1925

Axis of Cylinder Normal Position

Axis of Coil Tipped East and West

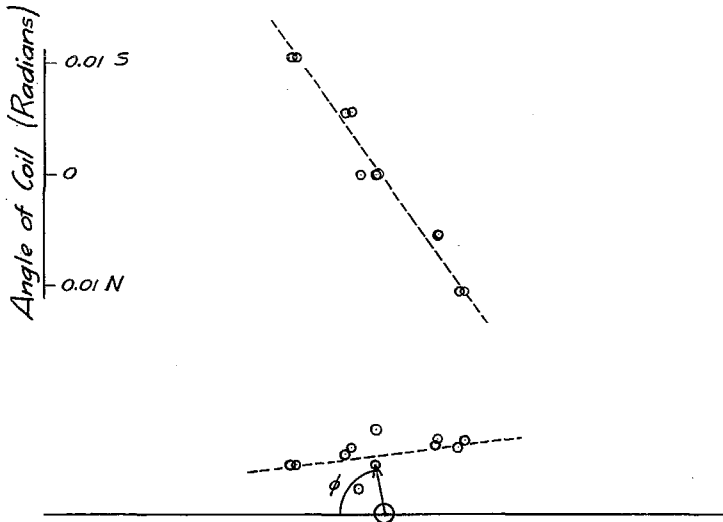


Plot No. 3

July 25, 1925

Axis of Cylinder Set 0.00604 Radians North

Axis of Coil Tipped North and South

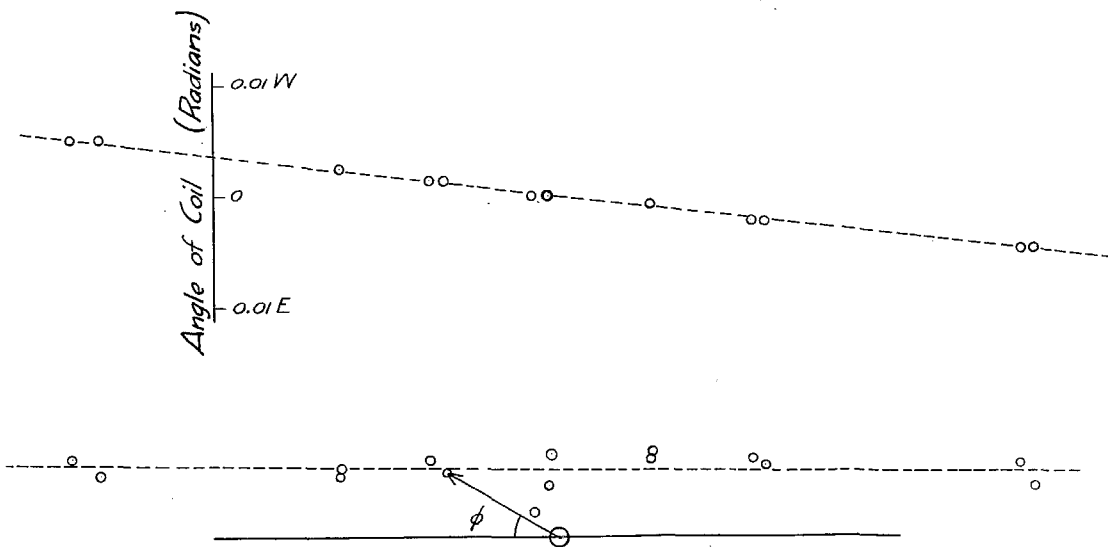


Plot No 4

July 25, 1925

Axis of Cylinder Set 0.00604 Radians North

Axis of Coil Tipped East and West

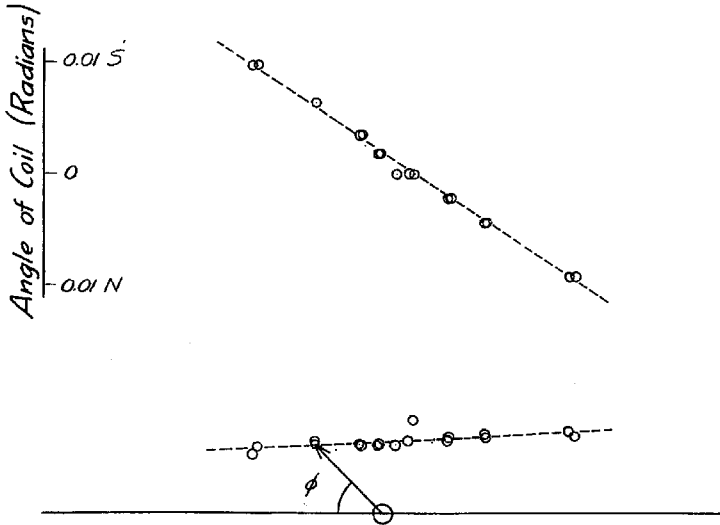


Plot No. 5

July 27, 1925

Axis of Cylinder Set 0.00604 Radians South

Axis of Coil Tipped North and South

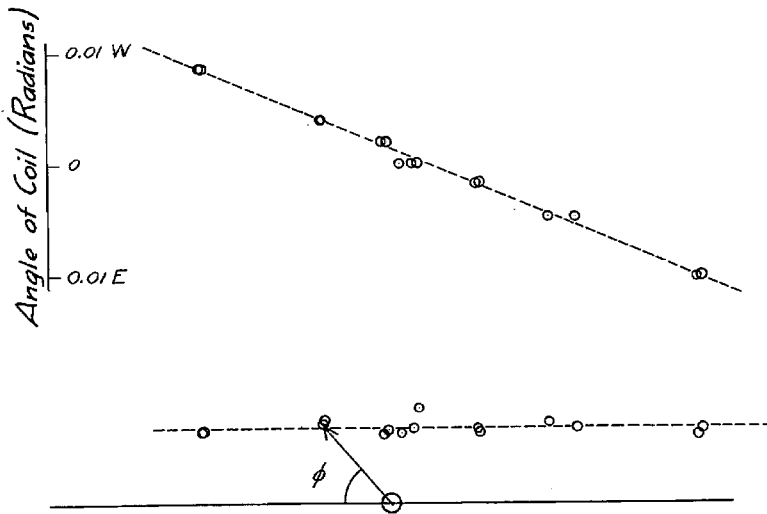


Plot No. 6

July 27, 1925

Axis of Cylinder Set 0.00604 Radians South

Axis of Coil Tipped East and West

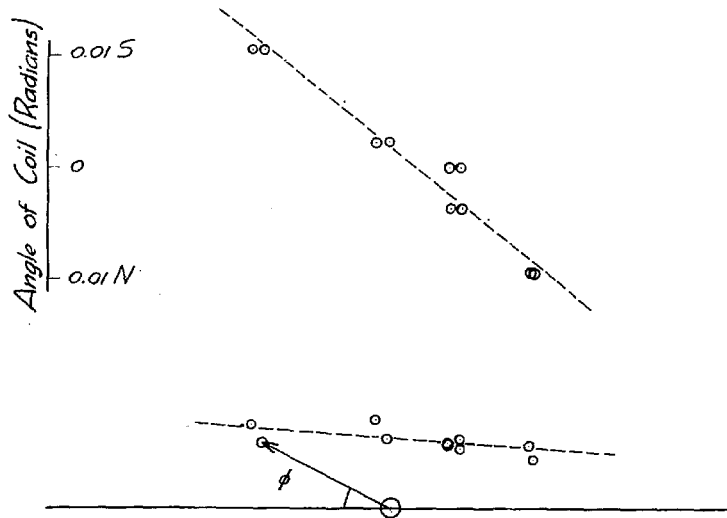


Plot No. 7

July 28, 1925

Axis of Cylinder Set 0.0231 Radians South

Axis of Coil Tipped North and South

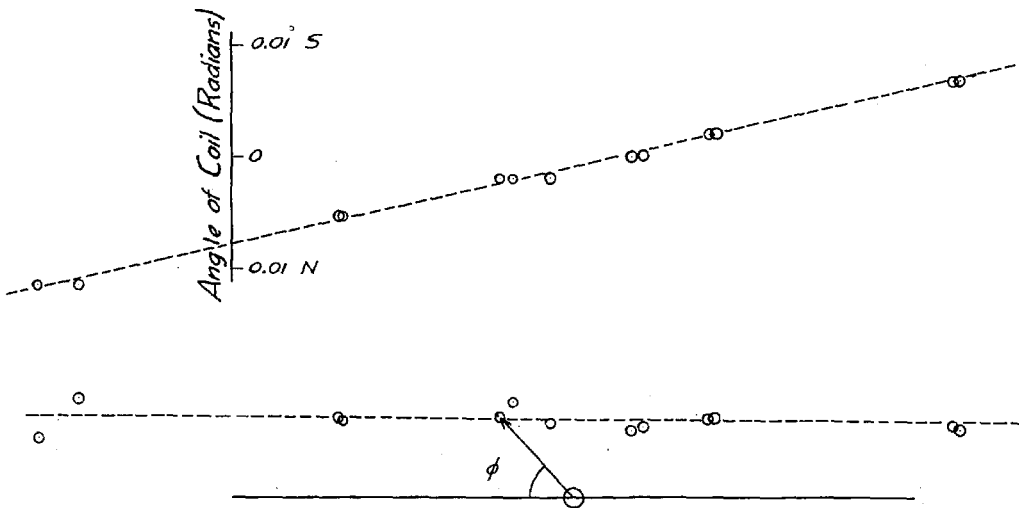


Plot No. 8

July 28 1925

Axis of Cylinder Set 0.0231 Radians South

Axis of Coil Tipped East and West

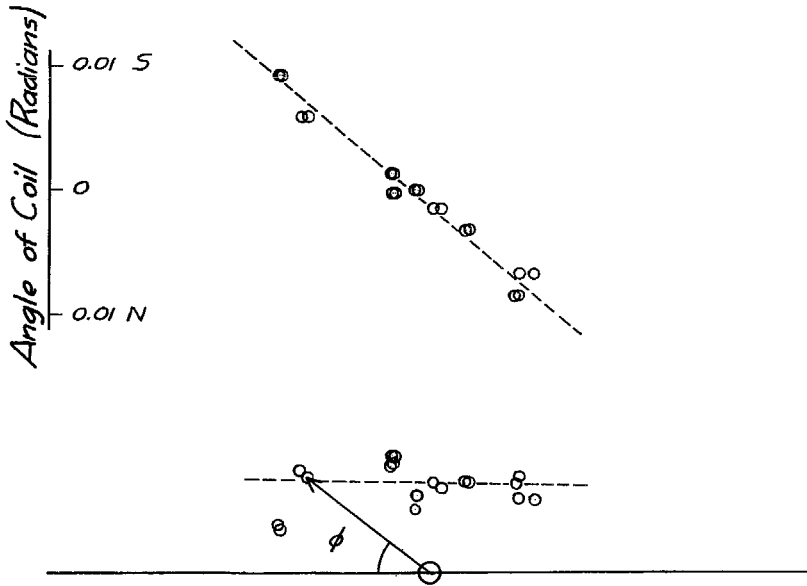


Plot No. 9

July 29 and 30, 1925

Axis of Cylinder Set 0.0116 Radians South

Axis of Coil Tipped North and South

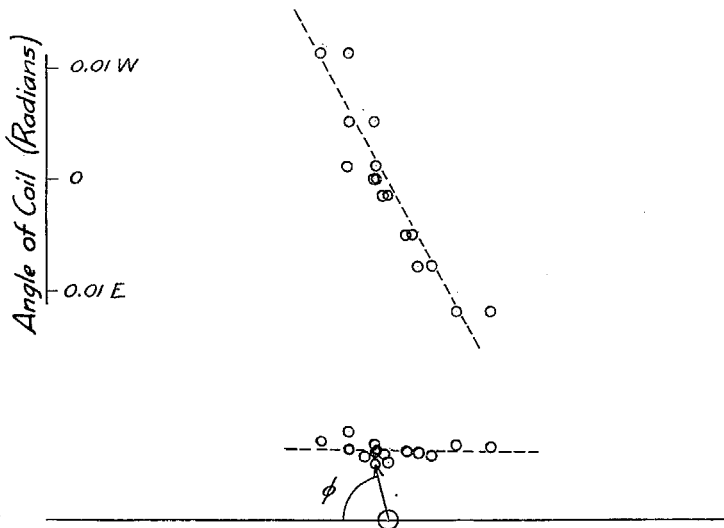


Plot No. 10

July 29, 1925

Axis of Cylinder Set 0.0116 Radians South

Axis of Coil Tipped East and West



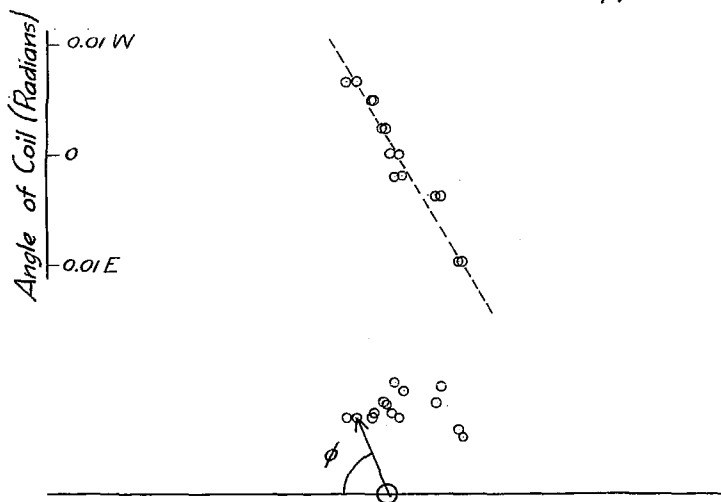
Plot No. 11

July 30, 1925

Axis of Cylinder Set 0.0116 Radians South

Axis of Coil Set 0.0015 Radians North

and then tipped East and West



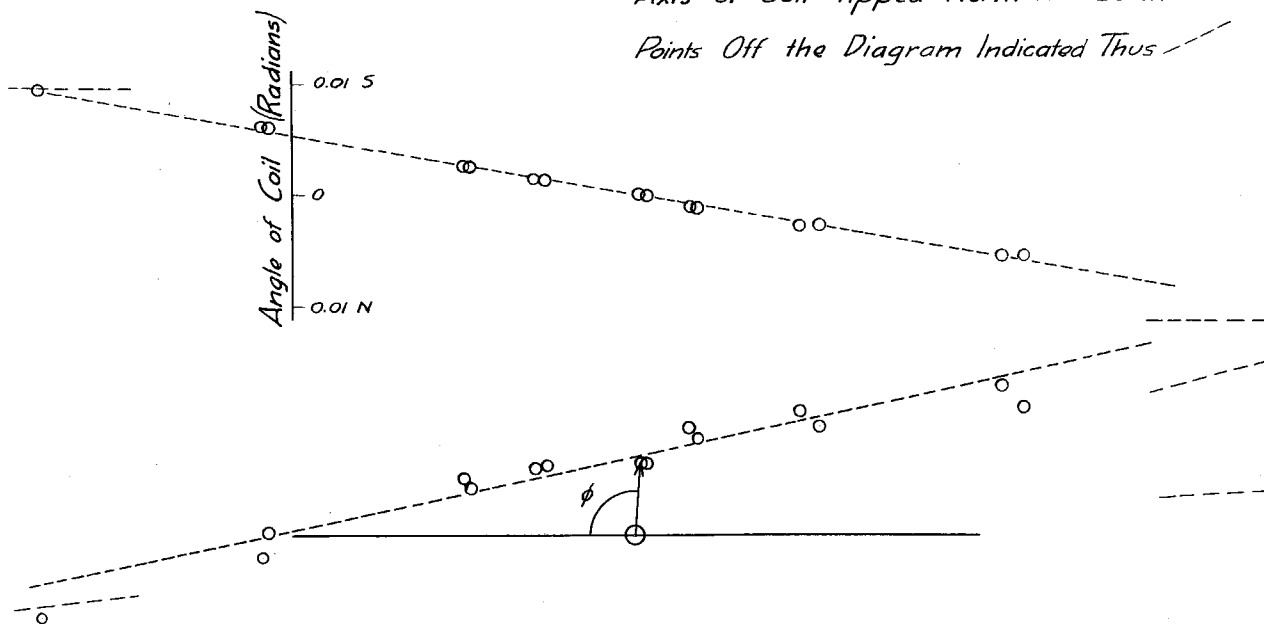
Plot No. 12

July 30 and 31, 1925

Axis of Cylinder Set { 0.0116 Radians South  
0.0111 Radians West

Axis of Coil Tipped North and South

Points Off the Diagram Indicated Thus

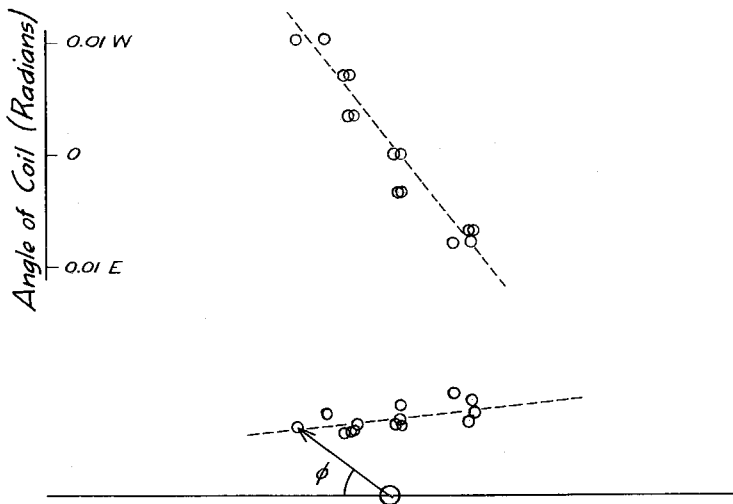


Plot No. 13

July 30 and 31, 1925

Axis of Cylinder Set { 0.0116 Radians South  
0.0111 Radians West

Axis of Coil Tipped East and West

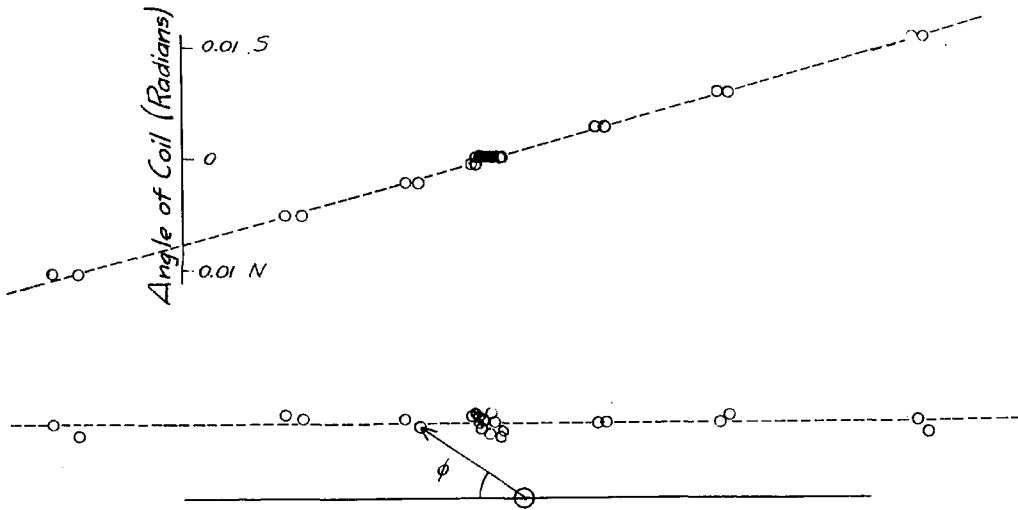




Plot No. 14

August 1, 1925

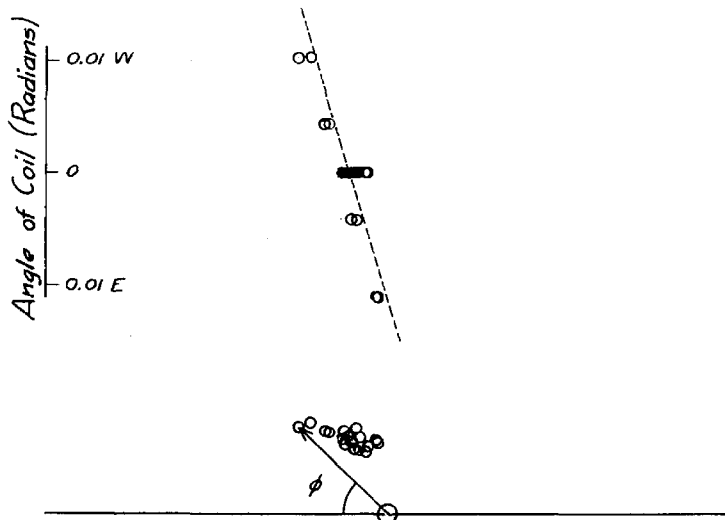
Axis of Cylinder Set  $\begin{cases} 0.0116 \text{ Radians South} \\ 0.0126 \text{ Radians East} \end{cases}$   
Axis of Coil Tipped North and South



Plot No. 15

August 1, 1925

Axis of Cylinder Set  $\begin{cases} 0.0116 \text{ Radians South} \\ 0.0126 \text{ Radians East} \end{cases}$   
Axis of Coil Tipped East and West

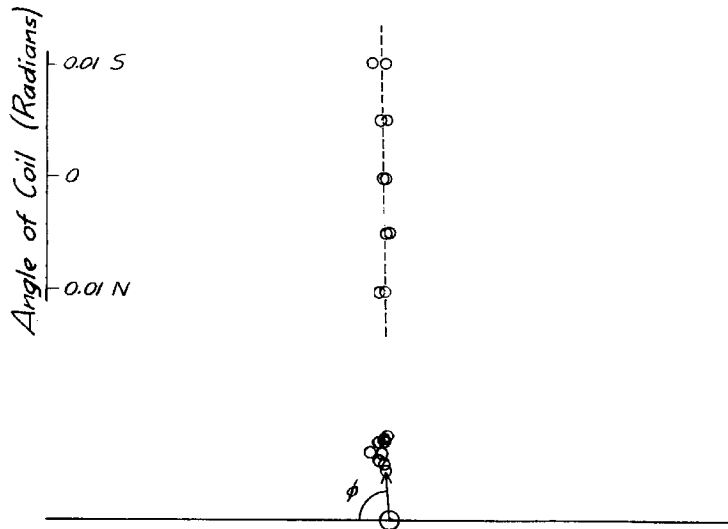


Plot No. 16

August 6, 1925

Axis of Cylinder Set  $\begin{cases} 0.0116 \text{ Radians South} \\ 0.0027 \text{ Radians East} \end{cases}$

Axis of Coil Tipped North and South

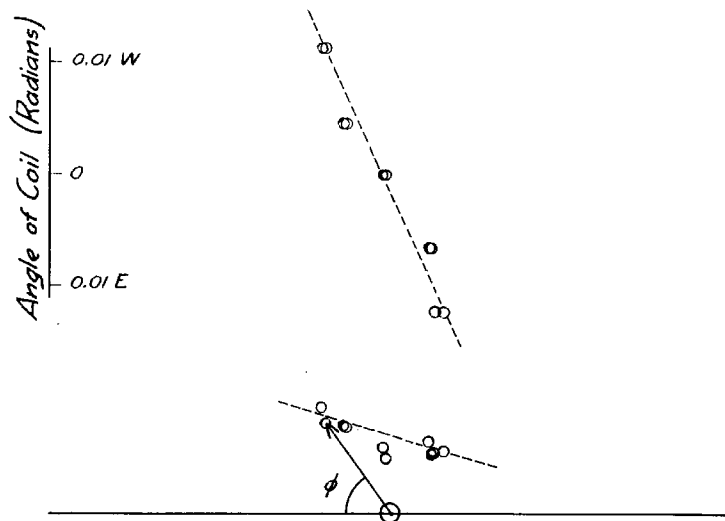


Plot No. 17

August 6, 1925

Axis of Cylinder Set  $\begin{cases} 0.0116 \text{ Radians South} \\ 0.0027 \text{ Radians East} \end{cases}$

Axis of Coil Tipped East and West

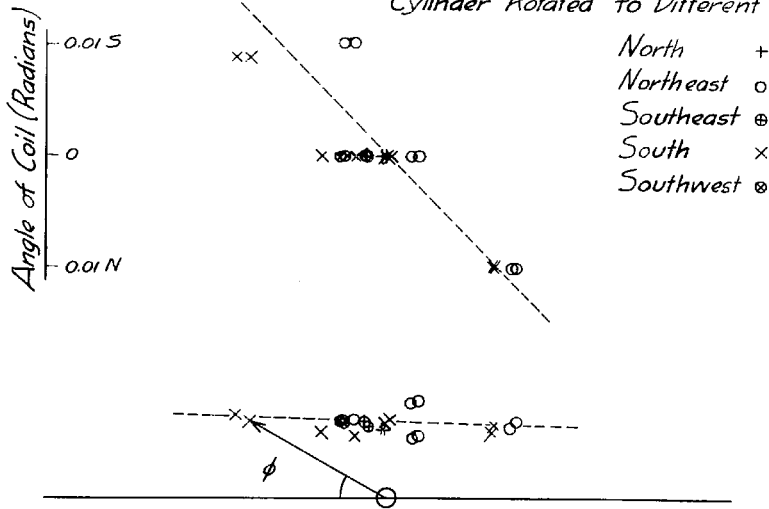


Plot No. 18

August 20 and 21, 1925

Axis of Cylinder Set  $\begin{cases} 0.0116 \text{ Radians South} \\ 0.0027 \text{ Radians East} \end{cases}$   
 Axis of Coil Tipped North and South

Cylinder Rotated to Different Positions

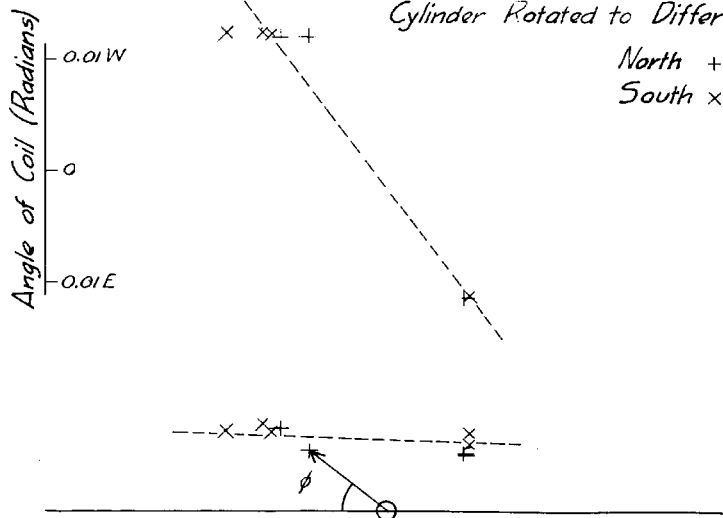


Plot No. 19

August 20 and 21, 1925

Axis of Cylinder Set  $\begin{cases} 0.0116 \text{ Radians South} \\ 0.0027 \text{ Radians East} \end{cases}$   
 Axis of Coil Tipped East and West

Cylinder Rotated to Different Positions



Plot No. 20

August 24, 1925

Axis of Cylinder in Normal Position

Axis of Coil Tipped North and South

Cylinder Rotated to Different Positions

Angle of Coil (Radians)

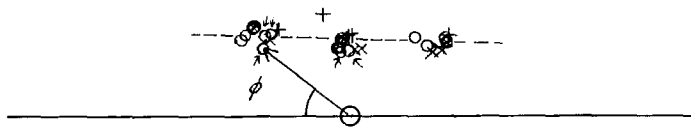
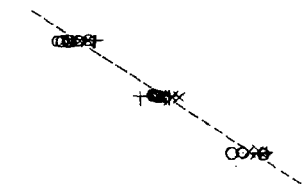
0.015

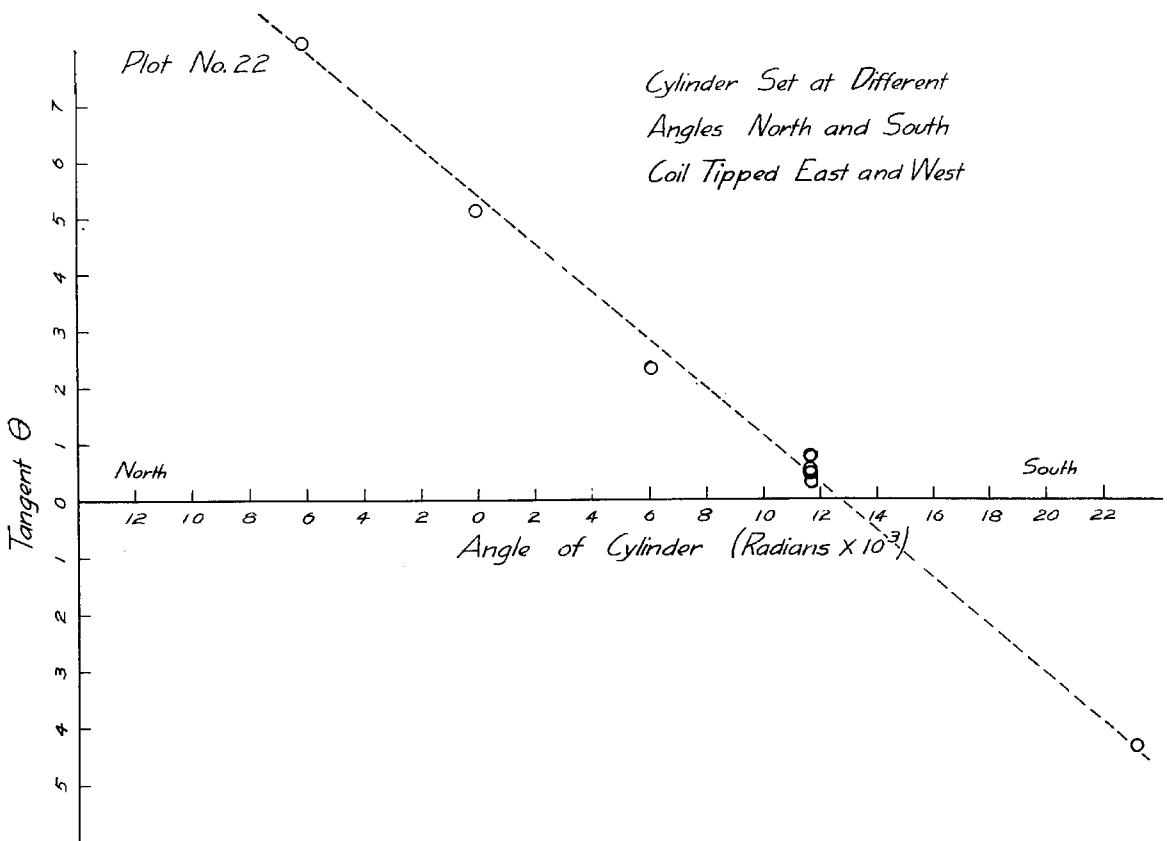
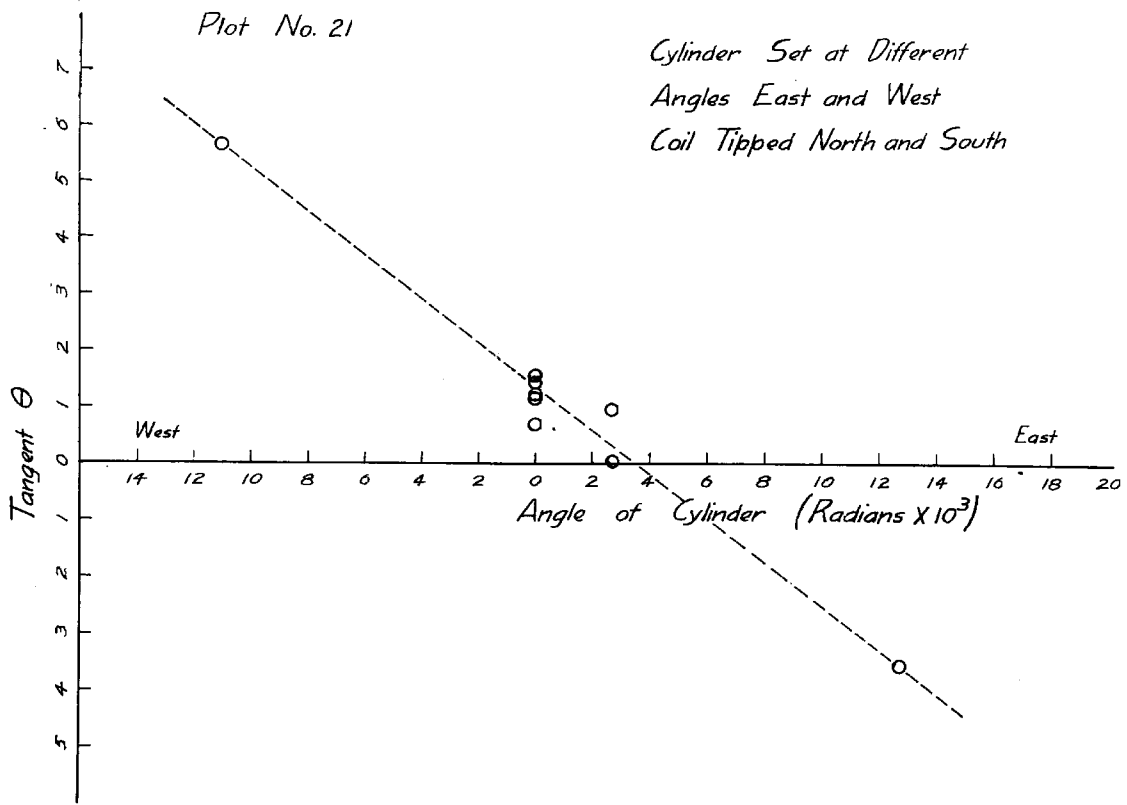
0

0.01N

North	+
Northeast	o
Northeast	⊗
South	x
Southwest	⊙

{ Torsion Rod  
Strained





THE LACK OF EFFECT OF A MAGNETIC FIELD ON THE DIELECTRIC CONSTANT  
OF HCl AND NO.

By Lewis E. Mott-Smith and Charles R. Daily

Recent theoretical investigations by Debye<sup>1</sup>, Ruark and Breit<sup>2</sup>, and others have made it of interest to look for a change in the dielectric constant of a gas when a strong magnetic field is applied to it. Experiments in search of this effect have been performed by Weatherby and Wolf<sup>3</sup>. They worked with helium, oxygen, and air and found that the dielectric constant of these gases does not change by more than one part in half a million when the gas is put into a magnetic field of 10,000 gauss. The dielectric constant was measured both parallel and perpendicular to the direction of the magnetic field with gas pressures of 20 cm. for helium and 76 cm. for air and oxygen. It is to be noted that none of these gases, helium, oxygen, or nitrogen, are gases of the so-called "Polar" class, which means that their molecules are known to have only a very small permanent electric polarization. At the suggestion of Dr. Linus Pauling it was accordingly thought interesting to try gases having a strong permanent electric dipole. HCl is definitely known to be such a gas from the work of Zahn<sup>4</sup>. The strength of the electric moment of the NO molecule has not been directly measured but there is evidence that it also has a rather large electric dipole. It is of interest to try both gases since HCl is diamagnetic and NO paramagnetic.

---

1 P. Debye, Phys. Zeit. 27, 67 (1926)

2 A. E. Ruark and G. Breit, Phil. Mag., 49, 504 (1925)

3 B. B. Weatherby and A. Wolf, Phys. Rev. 27, 769 (1926)

4 C. T. Zahn Phys. Rev. 24, 400 (1924)

The experimental procedure consisted in placing the gas to be investigated in a special parallel plate condenser which was placed between the pole pieces of a powerful electromagnet, and noting whether the capacity of the condenser changed when the field was applied. To detect a change in capacity a method was used similar to that first employed by Herweg and subsequently by several other investigators, including Weatherby and Wolf. In essence it consists in measuring the change in capacity by measuring the frequency produced in an oscillatory circuit formed by the condenser and an inductance. Continuous oscillations were maintained in this circuit by a special electron-tube oscillator circuit. To detect the change in frequency the main oscillator and another similar oscillator induced small EMF's in a detecting circuit, the difference in frequency being such that electrical beats were produced in this circuit. After rectification these became a low frequency alternating current which was then amplified and made to operate a simple oscillograph. The mirror of the oscillograph reflected light from a pinhole into a telescope and oscillated the spot up and down; the same beam of light was also reflected from a mirror attached to one of the prongs of an electrically driven tuning fork which caused the spot to oscillate horizontally. Lissajou's figures are thus produced when the two frequencies are commensurable. When they are not exactly commensurable but nearly so, the figure slowly changes from one shape to another. This arrangement gave us a sensitive method of detecting a change in the frequency of the beat note and consequently of detecting a change in the frequency of the gas-condenser-oscillator.

The gas-condenser was built up of interleaved flat copper plates spaced about 1 mm. apart and supported on a Pyrex frame. All the exposed metal parts were gold plated to prevent corrosion, the condenser was enclosed

in a glass tube and attached to the gas generating and pumping apparatus. Its capacity when evacuated was measured by comparison with a standard and found to be  $324 (10)^{-6}$  microfarad. The part of the capacity not influenced by the introduction of the gas was estimated to be only a few percent of the total capacity and it was therefore neglected in these experiments. To measure changes in capacity and to adjust the frequency of the oscillator to a stationary Lissajou figure a small variable condenser was connected in parallel with the gas-condenser. This was of the sliding coaxial cylinder type and was provided with a micrometer screw adjustment, the smallest division of which corresponded to a calculated change in capacity of  $9.10 (10)^{-9}$  microfarad. The electron-tube-driving-circuit was designed so as to have as small an influence as possible on the frequency of oscillation, in order that accidental changes in frequency due to variations in battery EMF's, or other changes in the driving circuit, might be as small as possible. This circuit arrangement maintained very feeble oscillations in the condenser circuit so that the maximum electric field in the condenser was about ten volts per cm. The frequency of oscillation was 168,000 cycles per second. The magnetic field was produced by a large electromagnet having flat pole faces to make the field as uniform as possible over the condenser area. The field strength was measured with a bismuth spiral and found to be 4800 gauss, and fairly uniform.

Preliminary experiments were made to see if any effect was produced by turning on the field while the condenser was evacuated, and to determine the sensitivity of the apparatus. It was found that at the instant of making or breaking the electromagnet circuit there was a slight jump in the figure but that after a few moments it again became stationary. To determine the sensitivity of our apparatus we first obtained a stationary



figure, then changed the capacity of the variable condenser until the figure could definitely be seen to be changing. It was found that a change in capacity corresponding to  $1/3$  division produced an easily detected movement in the figure. Since  $1/3$  division corresponds to a change in capacity of  $3.0 (10)^{-9}$  microfarads and the capacity of the gas condenser is  $324 (10)^{-6}$  microfarads it is seen that our apparatus is capable of detecting a change in capacity of this condenser of about 1 part in 100,000.

The HCl gas was handled in a manner similar to that used by Zahn. It was generated by dropping concentrated  $H_2SO_4$  on fused NaCl, passed over  $P_2O_5$  and collected by condensation into a liquid air trap. When sufficient gas had been collected the generator was closed off, the trap and condenser pumped out over the frozen HCl and a portion of the gas allowed to evaporate into the condenser. The pressures used were about 2.5, 10, 19 and 42 cm. of mercury. The magnetic field was applied both parallel and perpendicular to the electric field at each pressure. When the switch in the electromagnet circuit was closed no movement of the figure was detected at any pressure or direction of field, except the momentary jump mentioned above. This shows that to one part in 100,000 there is no change in the value of  $\epsilon$  for HCl. Since the value of  $\epsilon$  at room temperature and say 20 cm. pressure is 1.0010 we would have been able to observe a change in  $\epsilon - 1$  of 1.0%.

The nitric oxide gas was generated by dropping  $H_2SO_4$  into a solution of  $NaNO_2$ . It was passed through water to remove  $NO_2$  and through  $H_2SO_4$  to remove water vapor. Condensation by liquid air was found troublesome, hence the gas was collected into an evacuated chamber and thence allowed to escape into the gas-condenser. The pressures in this case were about 4, 13 and 40 cm. and again tests were made with the field in both positions. No effect was detected. In order to be able to say what frac-

tional change in  $\epsilon - 1$  would have been detected it was necessary to make a determination of  $\epsilon$  since this quantity has not yet been measured. A rough determination was made which gave at room temperature, and reduced to 76 cm. pressure, the value 1.00044. The detectable percent change in  $\epsilon - 1$  can now be calculated and gives the value 8.3% for a pressure of 20 cm. It is interesting to note that the dielectric constant is about the same as that of air which makes it appear possible that the electric moment of the NO molecule is not as large as has been supposed.

Our work thus shows that there is no large change in the dielectric constant due to a magnetic field even for polar molecules. Other polar molecules could be tried but the interest is not great since we cannot expect any difference in behavior. These experiments together with those of Weatherby and Wolf, therefore complete the experimental side of this question until a method more sensitive than one part in 100,000 is devised<sup>1</sup>. Experiments in this direction are now in progress.

Norman Bridge Laboratory,  
June 18, 1926

---

<sup>1</sup> The authors feel that the sensitivity claimed by Weatherby and Wolf is a little too high. By using the method which Weatherby and Wolf used of counting beats for a few seconds before and after the field is applied we also obtained results for which we could claim as high sensitivity. It is believed that the sensitivity determined in the manner explained above is the true one for our apparatus and that Weatherby and Wolf's results are reliable to no greater accuracy.