

EXPERIMENTAL DEFLECTION SURVEY OF
CANTILEVER SECTORS OF UNIFORM THICKNESS

Thesis by

Joseph Garrett, Lieutenant Commander, U.S.N.

In Partial Fulfillment of the Requirements

For the Degree of
Aeronautical Engineer

California Institute of Technology

Pasadena, California

1949

ACKNOWLEDGEMENTS

The author wishes to acknowledge his appreciation for the cooperation extended by the GALCIT staff during this investigation.

The author especially desires to express his gratitude to Dr. E. E. Sechler, Dr. G. W. Housner, and Mr. M. L. Williams for their helpful advice and their suggestions.

Acknowledgement is also made to Mr. B. W. Morant for his assistance in the construction of testing equipment and for his aid in the experimental work.

The research was carried out in collaboration with Lieutenant Commander William E. Henry, U.S.N.

TABLE OF CONTENTS

<u>PART</u>	<u>TITLE</u>	<u>PAGE</u>
	Summary	
I	Introduction	1
II	Equipment	3
	2.1 Test Specimen	3
	2.2 Testing Equipment	3
III	Initial Calibration and Preliminary Testing	6
IV	Experimental Procedure	8
	4.1 Procedure for Phase 1	8
	4.2 Procedure for Phase 2	9
V	Case of Distributed Loading	11
VI	Results and Discussion	16
	6.1 Results of Phase 1	16
	6.2 Results of Phase 2	19
VII	Recommendations	23
VIII	Conclusions	24
	References	25
	Tables	26
	Illustrations	38
	Appendix	

LIST OF FIGURES AND ILLUSTRATIONS

1. Plan Form of Phase 1 Specimen
2. Plan Form of Phase 2 Specimen
3. Arrangement for Securing Specimen
4. Arrangement for Loading and Measuring Deflection of Test Specimen
5. Sample Data Sheet
6. Arc Boundary Loading Condition No. 1
7. Arc Boundary Loading Condition No. 3
8. Arc Boundary Loading Condition No. 2
9. Deflections for Loading Condition No. 1
10. Deflections for Loading Condition No. 3
11. Deflections for Loading Condition No. 2

EXPERIMENTAL DEFLECTION SURVEY
OF CANTILEVER SECTORS OF UNIFORM THICKNESS

SUMMARY

The purpose of this investigation was to experimentally determine deflection data for 0 to 180 degree uniform thickness cantilever sectors. The basic deflection data is presented in the form of influence coefficients that can be utilized in the determination of the deflection of sectors as caused by any regular transverse loading.

One phase of the investigation was specifically planned to achieve results that could be compared with an analytical solution of the problem.

In addition to the basic experimentation, preliminary investigation was made of the effect of thickness and boundary fixity on the stiffness of cantilever sectors.

Deflection modes as calculated from the data of this investigation were in close agreement with those determined by the analytical solution. Agreement in absolute magnitude was of the order of 15 percent for three loading conditions checked.

Further investigation into the effect of thickness is considered desirable before the results of this investigation are applied to the determination of deflections for sectors of different thickness from those used in the investigation.

The investigation was carried out in the Guggenheim Aeronautical Laboratory at the California Institute of Technology, Pasadena, California.

EXPERIMENTAL DEFLECTION SURVEY
OF CANTILEVER SECTORS OF UNIFORM THICKNESS

I INTRODUCTION

The purpose of this investigation was to study the deflection of uniform thickness sectors when fixed on one radius and subjected to transverse loadings. The investigation was made using specimens of 24ST aluminum alloy. All loadings were below the proportional limit of the material.

The experimental work was divided into two phases:

Phase 1. Obtaining deflection data for a family of sectors of varying opening angle but with identical thickness and radius. The deflection data was reduced to influence coefficients that were arranged in matrix form. The sectors of this family varied in sector angle from 30 to 180 degrees.

Phase 2. Determining the deflection pattern of a 45 degree sector when subjected to a particular boundary loading. This phase was for the purpose of obtaining results that could be compared with results of an analytical solution. ⁽¹⁾ The second phase also included a preliminary investigation of the effect of thickness and boundary fixity on the deflection of sectors for the particular case of 45 degree opening angle.

The testing equipment was designed and built by the author in collaboration with William E. Henry, and utilized the basic facilities of the GALCIT* structures laboratory.

*Guggenheim Aeronautical Laboratories, California Institute of Technology, Pasadena, California.

A major portion of the time was spent on the development of procedures and techniques which would permit the investigation to proceed more rapidly and yield data that could be used for the determination of deflections caused by any kind of transverse loading.

II EQUIPMENT

2.1 Test Specimens

The basic specimen used in Phase 1 of this investigation was cut from 1/4 inch aluminum alloy plate. The original specimen was 19.94 inches in radius, had an average thickness of 0.251 inches and a sector angle of 180 degrees. Sectors of 135, 90, 75, 60, 45, and 30 degrees were obtained by progressively cutting back the basic specimen. Figure 1 shows the plan form of the specimen with its 19-1/2 x 20 inch hold-down extension. A 2 inch by 15 degree polar grid was lightly scribed on both sides of the specimen after it had been painted with a light coat of Dykem Blue.

The specimen used in Phase 2 of this investigation was cut from 1/8 inch 24ST aluminum alloy plate. The average thickness of this specimen was 0.125 inches. The overall radius was 25 inches and the effective radius was 20 inches. Radial saw cuts were made between the above mentioned radii at 1 inch intervals along the effective circumference. Figure 2 shows the plan form of the specimen used in Phase 2.

2.2 Testing Equipment

The testing equipment was constructed using an existing steel frame as a supporting base. Two 2-1/2 x 4 x 3/4 inch angle sections approximately 43 inches long were leveled and secured to the existing base frame. The upper horizontal surface of the angle irons had been machined to provide a level surface for the hold-down plates. Two stress relieved and machined 1 x 29 x 19-1/2 inch steel hold-down plates were secured to the angle irons by 12 steel bolts. The specimen was inserted between the hold-

down plates and shims 1/32 inch thinner than the specimen were used to prevent excessive "bowing" of the hold-down plates. Since no bolts could be used near the line of fixity of the specimen, three screw jacks were employed to increase the pressure of the upper hold-down plate on the specimen. The screw jacks used were sufficient to cause noticeable concave bending of both hold-down plates. Figure 3 shows the arrangement used to secure the specimen.

The loading device permitted the application of point loads from above by the use of a loading pin to which weights were added. The point of the loading pin was ground to as small a radius as possible without its causing damage to the specimen during repeated loading.

The movement of the load to the various grid points was accomplished in the following manner:

(a) The loading pin was raised from contact with the specimen by a four foot lever arm that had a fulcrum above the sector center.

(b) The lever arm, carrying the loading pin with it, could be rotated about the sector center throughout the required 180 degrees.

(c) Radial motion of the loading pin was accomplished by means of rollers on the guiding mechanism. These rollers acted on the lever arm and could be locked at any radial position.

(d) The loading pin guiding mechanism was so arranged that when the load was positioned on the specimen neither the lever arm nor the guiding mechanism took any appreciable amount of the vertical load.

Further information on the mechanical details of the loading can be obtained from Figure 3.

A deflection table was positioned parallel and 9-1/2 inches below the lower surface of the specimen. This deflection table consisted of an ordinary office table that was secured to the testing frame by means of "C" clamps. A 30 x 60 inch smooth surface top was made from 1/4 inch masonite glued to 1 inch plywood. When rigidly clamped to the table this top provided a smooth and steady platform from which the deflections could be measured. Since there was no weight on the table other than the deflection gauge, no additional rigidity of the table was deemed necessary.

A deflection gauge was made by mounting a Model 282 Ames dial gauge of 1 inch travel and reading to 0.001 inch on a sturdy base. The main spring of the dial gauge was removed and a uniform gauge force was obtained by gravity action on a horizontal 8 inch aluminum bar supported at an off-center pivot. The overall height of the deflection gauge was made adjustable by the addition of precision ground base blocks.

Figure 4 illustrates the operation of the deflection gauge.

III INITIAL CALIBRATIONS AND PRELIMINARY TESTING

Preliminary tests for the purpose of determining the most desirable experimentation techniques were conducted on a 0.075 inch 24ST aluminum specimen. Early investigation indicated the desirability of loading the specimen by gravity from above while deflections were being measured from below.

The following general requirements were set forth:

(a) Maximum deflections must be as large as possible to keep reading errors to a minimum, but measureable permanent set of the specimen must not result.

(b) The loading must be as large as possible within the limits of (a) above and yet permit easy manual handling.

(c) Sector angles from 0 to 180 degrees must be investigated.

(d) From the data obtained it must be possible to determine the deflection of a specimen under any form of transverse loading.

In view of the above requirements, it was decided that the superposition of deflections caused by point loads would be utilized and, further, that Maxwell's Reciprocal Theorem would be used to minimize the amount of data required.

The preliminary investigation utilized a standard spring-loaded dial gauge and the results obtained did not agree with Maxwell's Reciprocal Theorem. Two possible causes for this discrepancy were investigated.

(a) Fixity of the specimen in the test equipment.

(b) Linear variation in the deflection gauge force on the specimen because of the main spring of the dial gauge.

By replacing the main spring of the dial gauge with a lever system that produced a uniform deflection gauge force throughout its range of travel, the results were found to satisfy Maxwell's Reciprocal Theorem. By repeated testing it was determined that Maxwell's Reciprocal Theorem would yield results within the scatter caused by repeated readings for any one point. Superposition was checked by comparing results with those of a survey made with a uniform load on a 45 degree sector.

By plotting deflection data from the preliminary investigation, the distribution and density of loading points were decided upon.

It was determined that the most accurate results could be obtained by leaving the deflection gauge under a given point while the load was moved from point to point. This testing procedure eliminated errors that might result from irregularities in the deflection table if the gauge were moved between readings. It also made it possible to obtain a check on the tare reading after each load had been removed. A third advantage of this method of testing over an alternate method* was that deflections could be read directly without need for subtracting a tare reading each time.

* The deflection gauge can be moved to each of the load points while the load is at one load point.

IV EXPERIMENTAL PROCEDURE

4.1 Procedure for Phase 1.

The 180 degree sector was the first specimen surveyed. It was secured in the test equipment and random deflection readings were taken to insure that the data would satisfy Maxwell's Reciprocal Theorem. Fifty-three grid points were selected as test points. The deflection meter was placed under a test point and the gauge zeroed with no load applied. Weights had been attached to the loading pin to make its total weight 50 pounds. The loading pin was progressively moved to all test points. Deflection readings as read were multiplied by 20 and were recorded on data sheets. The numbers recorded, therefore, represented inches of deflection per 1000 pounds and are hereafter referred to as influence coefficients designated as g_{ij} . (2)

By employing Maxwell's Reciprocal Theorem, once the deflection gauge had been under a test point and all readings taken, that point never had to be used again as a loading point.

Upon completion of the deflection survey, the data was transcribed to the more convenient matrix form of Tables 1 to 7.

The data for each test point was examined for large discrepancies by drawing contour lines on the rough data sheets. Figure 5 illustrates a data sheet that had been examined in this manner.

Upon completing a check of all the data for the 180 degree sector, that specimen was removed, cut back to 135 degrees, and the above testing procedure repeated.

Similar experimental procedure was followed with the 90, 75, 60, 45,

and 30 degree specimens. The test points used for each specimen are indicated by the data in Tables 1 to 7.

4.2 Procedure for Phase 2.

The method of measuring deflections in this phase was the same as for Phase 1 except that Maxwell's Reciprocal Theorem was not utilized.

A distributed boundary loading of -49.90 inch pounds radial moment per inch and -10.40 pounds shear per inch was imposed over one inch of the effective circumference by placing a 10.40 pound load 4.80 inches from the root of a finger. Deflections were recorded as the load was moved to each of the 15 fingers that were 1 inch wide at the root. A modified procedure was used in the case of the 16th finger that was 0.71 inch wide at the root.

Influence coefficients for the shear alone were obtained directly from deflection readings taken when a 10 pound concentrated load was placed at the root of each finger.

Influence coefficients for radial moment alone were calculated from the data by the method illustrated in the Appendix of this report.

The above procedure was repeated for the same sector after all fingers had been split to one-half their original width. The results were compared and then all except 3 of the narrower fingers were cut off at their root and the procedure repeated for those three fingers.

By making a plot of all coefficients against arc position, and including on that plot the values from the three finger test, it was possible to correct the original data for the effect of the fingers on the plate stiffness.

Table 8 gives the reduced data for the 1/8 inch, 45 degree sector as corrected for the above mentioned effect.

A preliminary investigation was made of the relative stiffness of the 1/4 inch plate and the 1/8 inch plate used in the two phases. This investigation was made by comparing the corresponding elements of the respective matrices of influence coefficients for five points on the free boundaries. Table 9 shows the comparison of stiffness for the five points investigated.

The effect of the fixity conditions was estimated by comparing the tip deflections as obtained with the screw jacks not present and with them tightened an extreme amount. By this procedure the effect of fixity was considered to have been bounded.

V CASE OF DISTRIBUTED LOADING

The determination of the deflection of a sector plate caused by a distributed load requires that an area coefficient designated " a_j " be associated with each of the loading points of the influence coefficient matrix. If in the symmetrical influence matrices formed in this investigation there are " n " loading points designated by subscripts " j " there are " n " deflection points designated by subscripts " i ". Now if q_j is the loading intensity of the distributed load at the load point " j " an equivalent concentrated load p_j can be defined as follows:

$$p_j = a_j q_j \quad (1)$$

If w_i is the true deflection of the sector at point " i " due to a distributed loading the rigorous requirements for the area coefficients become

$$w_i = \sum_{j=1}^n p_j \epsilon_{ij} = \sum_{j=1}^n a_j q_j \epsilon_{ij} \quad (2)$$

where (2) must be satisfied for all deflection points simultaneously.

To meet these requirements a_j would be a function dependent upon:

(a) The geometric position of " j " with respect to other load points and the plate's boundaries,

(b) The load distribution,

(c) The deflection mode near " i ".

Accordingly a_j cannot be uniquely defined for all values of load distribution and still satisfy the requirements exactly.

For regular loading distributions and resulting deflection patterns a unique a_j can be assigned each loading point that will satisfy Equation (2) to an acceptable degree of accuracy. The accuracy will be dependent upon the variation from the ideal in the load distribution and deflection pattern.

For this specific investigation the assignment of unique values to the area coefficients was based on two approximations.

(a) The load distribution was taken to be constant over each elemental area a_j .

(b) Influence coefficients varied in a linear manner between adjoining grid points.

In Phase 1, where for reasons previously mentioned the loading points were selected arbitrarily, an unsymmetrical distribution of load points exists. This lack of symmetry made it impractical to establish one general rule for the determination of all area coefficients. Typical examples for elements as illustrated in Figure (a) follow:

Area $A_1^{(1)}$ bounded by or containing load points a, b, g, f, k, and e was distributed to those points as follows:

$$\frac{A_1}{8} \text{ to each a, b, g, and f.}$$

$$\frac{A_1}{2} \text{ to internal point e.}$$

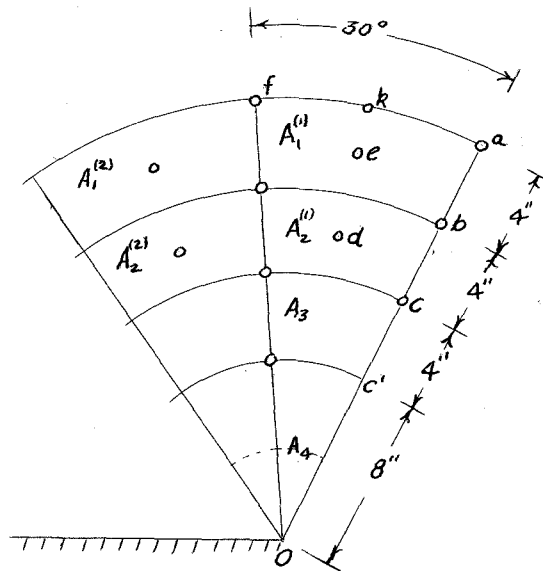

Figure (a)

0 to k. (This assignment of zero to k was made since k was an unsymmetrical point which was originally selected as a load and deflection point because of its importance in the case of boundary loadings. It could be illustrated that failure to assign an area

coefficient to this point does not cause it to be eliminated as a deflection point.)

To justify the assignment of $\frac{A_1}{2}$ to point "e" examine a geometrically similar internal point "g" which would be assigned $\frac{A_m}{8}$ from each of its four adjoining areas.

The typical area coefficients become:

$$\begin{aligned} a_a &= \frac{A_1}{8} & a_f &= \frac{A_1}{4} & a_e &= \frac{A_1}{2} \\ a_k &= 0 & a_g &= \frac{A_1}{4} + \frac{A_2}{4} & a_b &= \frac{A_1}{8} + \frac{A_2}{8} \end{aligned}$$

For the area c, h, i, c' (where c' is not a loading point) the area A_3 is first distributed equally to the four corner points. That area which was assigned to c' is then redistributed to c and o inversely as the distance from c' to those points. This arbitrary method of area assignment for elements near the center of the sector is based on the approximation that the load distribution will be nearly constant and that the deflection between the two points will be linear.

Writing the deflection for any point we have

$$\begin{aligned} w_i &= a_a q_a g_{ia} + a_b q_b g_{ib} + \dots + a_i^* q_c g_{ic} + a_{c'} q_{c'} g_{ic'} + \\ &\dots + a_o q_o g_{io} \end{aligned} \quad (3)$$

where a_c^* would be the area coefficient of point c if c' were a real load point. The last term of (3) vanishes since g_{io} must be zero where the fixed radius does not deflect.

Considering only that part of the deflection which is caused by the loading near c and c' we have

$$w_i^1 = a_c^1 q_c g_{ic} + a_{c'} q_{c'} g_{ic'} \quad (4)$$

Then if g_{ij} varies linearly and $q_{c'} = q_c = q_0$ from the assumptions made Equation (4) can be written

$$w_i^* = a_c^* q_c g_{ic} + a_{c'} q_{c'} \cdot 2/3 g_{ic} \equiv a_c q_c g_{ic} \quad (5)$$

or

$$(a_c^* + 2/3 a_{c'}) q_c g_{ic} = a_c q_c g_{ic} \quad (6)$$

and

$$a_c = a_c^* + 2/3 a_{c'} \quad (7)$$

where a_c is the total area coefficient of the point "c".

Equation (7) illustrates that for the approximations made there is justification for the arbitrary assignment of the area assumed by a non-load point to other load points in the inverse ratio of distance to those points.

Since on a fixed boundary g_{i0} vanishes, the area coefficients assigned to the boundary points have no significance except to provide a check. The area of the sector must equal $\sum_{j=1}^n a_j + a_0$.

Tables 10 and 11 have tabulated values for the area coefficients assigned each loading point of the sectors investigated. Because these area coefficients are for sectors of 20 inch radius multiplication by $r^2/400$ is required to reduce them to coefficients for other radii. It should be noted that while the area coefficients as defined here have dimensions of square inches no attempt was made to associate any given boundary with the area except to imply that it is in the vicinity of the corresponding load point.

For convenience of notation the area coefficients for each specimen investigated are arranged in column matrix form and designated as $\{A\}$.

The arrangement of the elements in the column matrix is made to correspond with the order of the load points in the associated influence coefficient matrix.

VI RESULTS AND DISCUSSION

6.1 Results of Phase 1.

The results of Phase 1 of this investigation are contained in the matrices of influence coefficients, Tables 1 through 7. Column matrices of the associated area coefficients are given in Tables 10 and 11. The results as presented are applicable to 20 inch radii cantilever sectors of 24ST aluminum 1/8 inch thick and for loadings within the proportional limit of the material. By use of the coefficients presented the deflection resulting from a transverse loading on any thin cantilevered sector of from 0 to 180 degrees can be ascertained.

A deflection caused by a concentrated load P_j at any grid point "j" is given by

$$w_i = P_j \xi_{ij} \times 10^{-3} \quad (8)$$

This deflection occurs when the sector is geometrically and physically identical to the sector used in this investigation. Within the region of proportional stress-strain the accuracy of the deflections determined for this type of loading is governed only by the accuracy of the values of the influence coefficients.

Possible sources of error in the tabulated influence coefficients are:

- (1) Method used in measuring deflections,
- (2) Method of loading test specimen,
- (3) Fixity of specimen at its supporting radius,
- (4) Imperfections in the test specimen.

*Double indices do not indicate summation over j.

By taking repeated test readings and by utilizing Maxwell's Reciprocal Theorem it was estimated that because of (1) and (2) the coefficients may have a scatter of $\pm .5\%$ or $\pm .02$ whichever may be the larger. From the preliminary investigation the errors caused by (3) were bounded by an upper and lower limit that were in variation by 5 percent. The material property curves indicate that the error caused by (4) should be of magnitude less than 2 percent.

For concentrated loads at points other than the loading points used in this investigation, interpolation of the data by graphical or algebraic methods can be employed. The accuracy of the interpolation and the accuracy of the influence coefficients will both affect the accuracy of the final results. For deflections at points other than grid points and for deflection surveys of sectors of intermediate sector angles a similar interpolation can be used.

For a continuous finite transverse shear loading on the free boundary of the sector, the deflection at any grid point is found by graphical or analytical evaluation of the integral.

$$w_i = \sum_s V(s) g_i(s) \Delta s \quad (9)$$

The process of evaluating and using $g_i(s)$ for the boundary from a finite number of g_{ij} values may introduce interpolation errors in addition to those existing in the basic data. Where reasonable methods of interpolation are employed these errors will not be accumulative but will average out and, therefore, be admissible.

Deflection surveys for distributed transverse loadings over the plan form of the sector provide the type loading of the most general interest. Distributed loadings including uniform loads and loads of the nature encountered by airfoils in subsonic or supersonic flow are of special interest if the approximation of airfoils by thin plates of uniform thickness is permitted. Such loadings can be treated from the data obtained in this investigation.

For the case of a distributed load of intensity q_j at grid point "j" the deflection is approximated by

$$w_i = \sum_{j=1}^n q_j a_j \xi_{ij} \times 10^{-3} \quad (10)$$

or in matrix form

$$[G]_{\alpha} \{Q\}_{\alpha} = \{W\}_{\alpha} \quad (11)$$

where $[G]_{\alpha}$ is the symmetrical square matrix of influence coefficients for a sector with sector angle .

$\{Q\}$ is the column matrix formed by the products $a_j q_j$

$\{W\}$ is the column matrix formed by elements w_i of the deflection.

Possible sources of error in deflections determined from Equation (11) are:

(1) Errors in influence coefficients,

(2) Errors in area coefficients as discussed in an earlier section

of this report.

In the case of loadings that are discontinuous or have discontinuous derivatives less accurate results may result. In the case of such loadings

accuracy could be improved by effectively increasing the density of the test points through interpolation. This procedure would require the determination of additional influence coefficients by interpolation and the reassignment of area coefficients to all loading points.

For sectors of thickness, radius, or material constants different from those used in the investigation, the determination of absolute deflections can be accomplished through the use of the elasticity relationships that are applicable to thin plates. (3)

6.2 Results of Phase 2.

The influence coefficients obtained for transverse shear and for radial moments acting on the arc boundary of the 45 degree sector used in this phase are given in Tables 8(a) and 8(b). Coefficients for transverse shear are designated $v_{\xi_{ij}}$ and are numerically equivalent to the deflection in inches at "i" caused by 1000 pounds shear per inch acting over one inch of arc at "j". Influence coefficients for radial moments are designated $m_{\xi_{ij}}$ and correspond to deflection at "i" caused by 1000 inch pounds radial moment per inch of arc acting over 1 inch near "j". The coefficient $c_{\xi_{ij}}$ represents deflection at "i" caused by 1000 pounds of concentrated load at "j" where, in this case, "j" is the free corner of the sector, namely, 45 degrees and 20 inches.

The coefficients given in Tables 8(a) and 8(b) are applicable to 24ST aluminum sectors of 20 inch radius and 1/8 inch thickness. By superposition, the deflection of such a sector caused by any given boundary loading is given by the equation

$$w_i \times 10^3 = \sum_{j=1}^{15} V_j \cdot \sqrt{\epsilon_{ij}} + .71 V_{(16)} \epsilon_{i(16)} \\ + \sum_{j=1}^{15} M_j \cdot m\epsilon_{ij} + .71 M_{(16)} m\epsilon_{i(16)} + P_c \epsilon_{ij} \quad (12)$$

where

V_j is the transverse shear in pounds per inch of arc near "j".

M_j is radial moment in inch pounds per inch of arc near "j".

P_c is concentrated load in pounds at 45 degrees and 20 inches.

For 45 degree sectors of thickness, radius, or material constants different from those of the sector used in this phase of the investigation, the determination of deflections can be accomplished through use of the elasticity relationships for thin plates.

The deflection at six points on the free boundary of the 45 degree sector were computed for three specific boundary loadings. The boundary loadings considered are given by Figures 6, 7, and 8. The deflections caused by these loadings as determined from Equation (12) are represented by Figures 9, 10, and 11 respectively. The loadings investigated correspond to loadings for which an analytical solution has been obtained by Williams.⁽¹⁾ The deflections given by the analytical solution are indicated on Figures 9, 10, and 11 along with the deflections as determined by this experimental method. While it is anticipated that there will be no more than minor changes in the analytical results, the author wishes to call attention to the fact that the comparisons made in Figures 9, 10, and 11 are therefore strictly valid only if no changes occur in the analytical solution wherein it applies to the loadings, deflections, and material properties used herein.

The following observations are considered significant:

(1) The order of magnitude of the maximum deflections as determined by the two approaches is the same.

(2) For the three loadings investigated all deflections in each case were less when determined experimentally than when determined analytically. This finding is contrary to what is normally found when experimental results are compared with analytical results, such as in beam problems. It is, however, in accordance with some preliminary results of a similar investigation on cantilevered rectangular plates.

(3) The deflection modes as determined by the analytical and experimental methods are similar. This observation indicates that good agreement might be expected for the stresses near the sector's boundaries as determined by the two approaches.

The results of a preliminary investigation into the effect of the thickness of sector plates on their stiffness are contained in Table 9. Deflection data for the 1/4 inch sector plate was compared with corresponding deflection data for the 1/8 inch sector of Phase 2. The elementary relationships of elasticity when applied to thin plates with small deflections give deflections inversely as the cube of the thickness. From that relationship the ratio of deflection of the .125 plate to the .251 plate would be 8.10: 1. For the five points investigated the experimental results indicate that the ratio of deflections is nearly constant and of the order of 7.30 : 1.

Possible causes for this variation that may have resulted from the experimental technique are:

(1) The thinner 1/8 inch plate may have permitted a higher degree of relative fixity at the supporting radius. Since the preliminary investigation into the effect of fixity indicated a maximum of 5 percent variation in deflections for various fixity conditions it is improbable that this is the only cause for the variation noted.

(2) There may exist a "thickness effect" which is accentuated enough by the geometry of the plate to require the use of the thickness term in the plate equations.⁽⁴⁾

(3) The material constants of the specimen were different from the values assumed in the calculation of the boundary loading, namely, $E = 10.3 \times 10^6$ and $\nu = .3$.

A complete investigation of the effect of thickness on the deflection of similar plates was beyond the scope of this investigation but, in view of the limited observations made, it must be concluded that further investigation is necessary before the results of this deflection survey can be accurately extended to sectors of thickness, radius, or material constants different from those of the test specimens used.

VII RECOMMENDATIONS

As a result of this investigation the following recommendations are made as to the nature of future experimentation with cantilever sectors:

(1) That a deflection survey be made of a cantilever sector, for any given transverse loading, by some alternate experimental method.

The agreement with the findings of this survey would give a quantitative indication of the accuracy to be expected in the use of the results of this investigation when extended to any of the many surveys that can be made from these results.

(2) That an alternate method of applying radial moments to the arc boundary be developed, and the results be compared with those of Phase 2.

(3) That an extensive investigation be made of the effect of plate thickness on stiffness.

(4) That surface stresses be determined at selected points on a given sector subjected to a given loading. Four alternate methods of determining, and checking, those stresses are suggested.

(a) Strain gauge readings with total load applied.

(b) By superposition of strain gauge readings for concentrated loads at grid points through the use of the area coefficients given in this investigation.

(c) By graphical or finite difference solution of the deflection survey made by this influence coefficient method.

(d) By the analytical solution.

(5) That in future investigations (particularly when thin plates are used) conditions at the fixed boundary be accurately controlled.

VIII CONCLUSIONS

The conclusions may be summarized as follows:

1. That the influence coefficients determined in this investigation provide sufficient and satisfactory basic data for determining the deflection of 0 to 180 degree cantilever sectors for any regular transverse loading.

2. That, for geometrically similar sectors that have the same boundary fixity, good agreement with deflections determined by other experimental methods can be expected.

3. That because of the technique used in securing the specimen to the test equipment the "effective fixity" at the supporting radius may have been even greater than that of a theoretically flat cantilever sector.

4. That further investigation, particularly into the effect of thickness on stiffness, is essential before the data obtained by this investigation can be accurately extended to thin sectors of thickness, radius, or material constants different from those of the test specimen used herein.

REFERENCES

1. Williams, M. L. "The Plate Problem for a Cantilever Sector of Uniform Thickness". Ph.D. Thesis, California Institute of Technology. Aeronautics Department (under preparation).
2. Kármán, T. V. and Biot, M. A. "Mathematical Methods in Engineering" pp 190, McGraw-Hill Book Company, Inc., New York and London, 1940.
3. Sechler, E. E. "Elasticity in Engineering", Chapter XII, California Institute of Technology. (To be published.)
4. Kármán, T. V. Article in Encyklopädie der Mathematischen Wissenschaften, Vol IV, (1910)
5. Timoshenko, S. "Theory of Plates and Shells" McGraw-Hill Book Company, Inc., New York and London, 1940.

TABLES

MATRIX OF INFLUENCE COEFFICIENTS*
FOR 90 DEGREE SECTOR

Radius - 20 inches
Ave. Thickness - .251 inches
24 ST Aluminum Plate

EG. IN.																															
15 6	.02																														
10	.02	.05																													
14	.01	.04	.10																												
20	.01	.04	.12	.52																											
20 12	.03	.10	.14	.16	.33																										
16	.03	.11	.23	.38	.44	.80																									
20	.04	.12	.31	.71	.54	1.12	1.92																								
#5 6	.04	.05	.04	.04	.14	.16	.16	.18																							
10	.05	.10	.13	.13	.37	.46	.54	.26	.54																						
14	.06	.14	.24	.32	.60	.90	1.14	.30	.76	1.30																					
18	.07	.18	.36	.56	.78	1.33	1.91	.34	.94	1.70	2.80																				
20	.08	.20	.41	.68	.87	1.56	2.31	.17	1.03	2.02	4.29	4.00																			
#0 8	.06	.09	.10	.08	.31	.36	.38	.32	.53	.68	.80	.84	.64																		
12	.08	.14	.20	.22	.58	.78	.90	.40	.86	1.33	1.72	1.88	.89	1.61																	
16	.10	.20	.32	.40	.83	1.24	1.60	.50	1.18	2.00	2.81	3.20	1.40	2.25	3.50																
20	.11	.25	.44	.60	1.10	1.74	2.30	.58	1.47	2.64	4.00	4.66	1.73	2.86	4.70	6.77															
5 10	.08	.12	.14	.11	.46	.56	.60	.44	.80	1.09	1.30	1.42	.96	1.52	1.97	2.38	1.68														
14	.10	.18	.25	.24	.76	1.01	1.16	.58	1.21	1.83	2.37	2.62	1.36	2.39	3.37	4.29	2.38	3.62													
18	.13	.24	.37	.40	1.03	1.45	1.80	.72	1.59	2.58	3.52	3.95	1.67	3.16	4.82	6.48	2.98	5.14	7.43												
20	.14	.27	.42	.49	1.17	1.69	2.08	.76	1.76	2.93	4.09	4.63	1.81	3.56	5.53	7.58	3.28	5.77	8.60	10.09											
0 4	.02	.03	.02	.00	.08	.07	.05	.16	.20	.20	.20	.18	.32	.35	.38	.40	.47	.56	.60	.64	.35										
6	.04	.06	.04	.00	.18	.18	.14	.28	.40	.44	.45	.45	.59	.71	.81	.88	.93	1.14	1.33	1.38	.47	.82									
8	.06	.08	.08	.03	.32	.34	.29	.40	.61	.74	.80	.82	.86	1.16	1.14	1.56	1.44	1.88	2.21	2.38	.55	1.04	1.52								
10	.08	.12	.12	.06	.44	.50	.47	.48	.83	1.08	1.22	1.27	1.07	1.61	2.03	2.37	1.94	2.68	3.26	3.53	.61	1.20	1.86	2.48							
12	.10	.15	.17	.10	.58	.69	.70	.58	1.06	1.44	1.70	1.80	1.32	2.09	2.75	3.29	2.41	3.56	4.42	4.88	.67	1.34	2.16	2.98	3.80						
14	.11	.18	.22	.16	.73	.90	.94	.67	1.29	1.82	2.22	2.37	1.53	2.57	3.49	4.28	2.85	4.38	5.72	6.32	.72	1.51	2.42	3.43	4.50	5.54					
16	.13	.21	.27	.21	.88	1.09	1.20	.75	1.50	2.20	2.74	2.98	1.76	3.04	4.28	5.34	3.23	5.16	7.01	7.88	.76	1.61	2.66	3.84	5.10	6.45	7.78				
18	.14	.24	.32	.27	1.02	1.29	1.47	.82	1.72	2.56	3.29	3.60	2.88	3.47	4.97	6.40	5.61	5.95	8.30	9.46	.84	1.76	1.95	4.22	5.67	7.27	8.94	10.54			
20	.16	.28	.36	.30	1.15	1.52	1.70	.89	1.90	2.92	3.83	4.23	2.13	3.91	5.76	7.52	4.00	6.72	9.64	11.08	.89	1.88	3.16	4.60	6.26	8.07	10.09	12.10	14.18		
G. IN.	15/6	15/10	15/14	15/20	30/12	30/16	30/20	45/6	45/10	45/14	45/18	45/20	60/8	60/12	60/16	60/20	75/10	75/14	75/18	75/20	90/4	90/6	90/8	90/10	90/12	90/14	90/16	90/18	90/20		

(Inches deflection per pound) x10³

TABLE 3

MATRIX OF INFLUENCE COEFFICIENTS*
FOR 75 DEGREE SECTOR

Radius - 20 inches
Ave. Thickness - .251 inches
24 ST Aluminum Plate

DEG. IN.	15/6	15/10	15/14	15/20	30/12	30/16	30/20	45/6	45/10	45/14	45/18	45/20	60/8	60/12	60/16	60/20	75/4	75/6	75/8	75/10	75/12	75/14	75/16	75/18	75/20	
15	.02																									
10	.02	.04																								
14	.01	.04	.12																							
20	.01	.04	.13	.54																						
30	.04	.10	.15	.17	.36																					
16	.03	.10	.24	.42	.46	.83																				
20	.03	.11	.32	.74	.56	1.17	2.00																			
45	.04	.04	.04	.03	.16	.16	.15	.20																		
10	.06	.10	.14	.14	.40	.47	.54	.28	.58																	
14	.06	.14	.26	.33	.62	.94	1.19	.31	.80	1.39																
18	.07	.18	.38	.60	.82	1.42	2.02	.34	.98	1.89	2.96															
20	.08	.20	.43	.72	.91	1.64	2.42	.35	1.04	2.12	3.48	4.22														
60	.06	.09	.10	.07	.33	.36	.36	.33	.57	.70	.80	.82	.70													
12	.08	.15	.22	.22	.63	.87	.93	.44	.95	1.42	1.80	1.94	.98	1.67												
16	.10	.20	.35	.42	.91	1.35	1.69	.51	1.26	2.16	3.01	2.38	1.20	2.43	3.80											
20	.12	.25	.46	.66	1.14	1.85	2.44	.55	1.52	2.34	4.28	4.99	1.40	2.98	5.04	7.34										
75	.03	.02	.02	.00	.09	.07	.04	.17	.20	.20	.18	.16	.30	.34	.35	.34	.27									
6	.06	.06	.05	.02	.20	.20	.16	.30	.41	.44	.46	.44	.58	.72	.78	.84	.36	.64								
8	.08	.10	.10	.05	.35	.36	.33	.41	.65	.78	.84	.85	.87	1.18	1.39	1.54	.40	.80	1.20							
10	.09	.13	.15	.10	.51	.57	.56	.50	.90	1.16	1.34	1.37	1.10	1.69	2.10	2.41	.44	.90	1.43	1.95						
12	.10	.16	.21	.17	.65	.80	.86	.55	1.10	1.57	1.90	2.00	1.26	2.14	2.89	3.44	.45	.98	1.61	2.30	2.94					
14	.12	.19	.27	.24	.82	1.07	1.19	.62	1.33	.99	2.53	2.70	1.44	1.64	3.72	4.58	.48	1.06	1.80	2.63	3.52	4.36				
16	.13	.22	.34	.33	.98	1.34	1.54	.67	1.52	2.40	3.17	3.47	1.60	3.05	4.53	5.80	.50	1.12	1.94	2.89	3.96	5.06	6.16			
18	.14	.24	.40	.42	1.15	1.58	1.91	.72	1.70	2.80	3.86	4.24	1.74	3.46	5.34	7.09	.52	1.20	2.07	3.16	4.38	5.71	7.10	8.90		
20	.14	.32	.45	.50	1.36	1.88	2.25	.80	1.92	3.24	4.50	5.04	1.90	3.88	6.12	8.36	.57	1.28	2.24	3.42	4.82	6.08	8.02	9.77	11.42	

TABLE 4

* (Inches deflection per pound) x10³

MATRIX OF INFLUENCE COEFFICIENTS*
FOR 60 DEGREE SECTOR

Radius - 20 inches
Ave. thickness - .251 inches
24 ST Aluminum Plate

15		6	.02																								
10		.01	.05																								
14		.02	.05	.12																							
20		.01	.05	.14	.55																						
30		12	.04	.11	.17	.18	.40																				
16		.04	.12	.26	.42	.51	.88																				
20		.04	.13	.34	.76	.59	1.23	2.08																			
45		6	.06	.05	.06	.02	.18	.16	.14	.24																	
10		.08	.12	.16	.13	.45	.52	.55	.32	.68																	
14		.09	.17	.28	.34	.70	1.02	1.26	.34	.88	1.54																
18		.09	.21	.41	.62	.90	1.55	2.17	.35	1.06	2.08	3.26															
20		.09	.22	.46	.77	1.02	1.81	2.66	.37	1.14	2.32	3.85	4.68														
60		4	.04	.02	.02	.00	.09	.02	.06	.18	.19	.17	.16	.17	.22												
6		.07	.06	.06	.02	.22	.20	.16	.32	.42	.43	.43	.44	.27	.49												
8		.09	.10	.11	.06	.37	.38	.35	.41	.67	.76	.82	.85	.28	.58	.86											
10		.10	.14	.18	.12	.55	.61	.62	.46	.90	1.17	1.33	1.40	.28	.62	1.02	1.41										
12		.11	.18	.24	.22	.72	.88	.95	.49	1.11	1.62	1.94	2.10	.29	.64	1.12	1.64	2.15									
14		.12	.22	.32	.32	.90	1.18	1.36	.52	1.28	2.07	2.64	2.89	.29	.68	1.19	1.79	2.46	3.12								
16		.12	.24	.39	.44	1.04	1.50	1.83	.55	1.42	2.44	3.39	3.79	.29	.70	1.26	1.96	2.75	3.62	4.47							
18		.13	.27	.46	.56	1.17	1.77	2.28	.56	1.55	2.84	4.15	4.72	.28	.71	1.30	2.08	3.03	4.08	5.21	6.29						
20		.14	.30	.52	.69	1.31	2.09	2.76	.59	1.68	3.16	4.83	5.67	.30	.74	1.40	2.24	3.27	4.48	5.80	7.23	8.56					
DEG. IN.		15/6	15/10	15/14	15/20	30/12	30/16	30/20	45/6	45/10	45/14	45/18	45/20	60/4	60/6	60/8	60/10	60/12	60/14	60/16	60/18	60/20					

TABLE 5

* (Inches deflection per pound) x10³

MATRIX OF INFLUENCE COEFFICIENTS*
FOR 45 DEGREE SECTOR

Radius - 20 inches
Ave. Thickness - .251 inches
24 ST Aluminum Plate

DEG.	INS.																							
7.5	20	.15																						
15	6	.00	.02																					
10	.00	.02	.06																					
14	.04	.01	.06	.14																				
16	.06	.01	.05	.15	.20																			
18	.14	.00	.05	.15	.22	.31																		
20	.21	.01	.04	.15	.24	.39	.57																	
22.5	20	.23	.01	.09	.27	.40	.57	.74	1.28															
30	.00	.05	.06	.07	.06	.05	.04	.10	.16															
12	.04	.04	.12	.20	.20	.19	.18	.38	.21	.44														
14	.06	.04	.13	.25	.28	.30	.30	.61	.20	.50	.66													
16	.12	.04	.14	.31	.37	.42	.45	.90	.21	.55	.77	.98												
18	.18	.03	.14	.34	.45	.55	.64	1.22	.20	.59	.86	1.17	1.50											
20	.24	.03	.15	.38	.55	.69	.82	1.59	.19	.62	.95	1.36	1.80	2.32										
37.5	20	.23	.05	.19	.47	.62	.73	.85	1.75	.28	.86	1.26	1.74	2.23	2.75	3.68								
45	.00	.03	.02	.02	.01	.00	.00	.01	.06	.05	.05	.04	.03	.05	.13									
6	.00	.06	.06	.04	.04	.02	.02	.05	.17	.16	.14	.14	.12	.12	.18	.14	.28							
8	.00	.07	.10	.10	.09	.07	.06	.14	.27	.31	.30	.30	.29	.27	.42	.13	.31	.50						
10	.02	.07	.14	.17	.16	.15	.12	.29	.32	.50	.52	.54	.53	.54	.80	.12	.31	.56	.80					
12	.04	.07	.18	.25	.26	.25	.22	.51	.35	.66	.76	.83	.87	.90	1.32	.11	.30	.57	.90	1.23				
14	.08	.07	.20	.33	.36	.37	.35	.79	.35	.79	.99	1.15	1.26	1.35	1.95	.09	.28	.57	.96	1.42	1.84			
16	.12	.07	.22	.41	.47	.51	.51	1.12	.36	.90	1.21	1.47	1.70	1.90	2.70	.09	.28	.57	1.01	1.55	2.11	2.67		
18	.17	.07	.23	.48	.58	.64	.68	1.47	.37	1.00	1.36	1.76	2.12	2.46	3.50	.08	.27	.60	1.05	1.66	2.36	3.11	3.88	
20	.22	.07	.27	.55	.69	.78	.86	1.84	.40	1.08	1.54	2.07	2.55	3.04	4.30	.08	.28	.60	1.09	1.75	2.58	3.51	4.59	5.57

TABLE 6

* (Inches deflection per pound) x 10³

DEG. INS. 7.5/20 15/6 15/10 15/14 15/16 15/18 15/20 22.5 30/8 30/12 30/14 30/16 30/18 30/20 37.5 45/4 45/6 45/8 45/10 45/12 45/14 45/16 45/18 45/20

MATRIX OF INFLUENCE COEFFICIENTS*
FOR 30 DEGREE SECTOR

Radius - 20 inches
Ave. Thickness - .251 inches
24 ST Aluminum Plate

DEG. IN.	7.5	10	14	16	18	20	22.5	30	4	6	8	10	12	14	16	18	20	75/20	15/6	15/10	15/14	15/16	15/18	15/20	20	22.5	30/4	30/6	30/8	30/10	30/12	30/14	30/16	30/18	30/20			
7.5	.13																																					
15		.00																																				
10			.01																																			
14				.03																																		
16					.04																																	
18						.04																																
20							.02																															
22.5								.07																														
30									.01																													
4										.05																												
6											.04																											
8												.07																										
10													.10																									
12														.10																								
14															.12																							
16																.10																						
18																	.11																					
20																		.10																				
75/20																			15/6	15/10	15/14	15/16	15/18	15/20	20	22.5	30/4	30/6	30/8	30/10	30/12	30/14	30/16	30/18	30/20			

* (Inches deflection per pound) x10³

TABLE 7

		i = 45° / 12"		i = 45° / 16"		i = 45° / 18"	
S	j	v ^ε _{ij}	m ^ε _{ij}	v ^ε _{ij}	m ^ε _{ij}	v ^ε _{ij}	m ^ε _{ij}
1.0	1	12.20	-.39	24.20	-1.29	32.50	-2.24
1.0	2	10.95	-.33	22.10	-1.17	29.65	-2.08
1.0	3	9.80	-.28	19.90	-1.06	26.75	-1.88
1.0	4	8.60	-.22	17.60	-.94	23.80	-1.66
1.0	5	7.32	-.17	15.35	-.80	20.80	-1.43
1.0	6	6.15	-.11	13.10	-.63	17.75	-1.20
1.0	7	5.10	-.07	10.90	-.48	14.85	-.98
1.0	8	4.10	-.02	8.95	-.36	12.10	-.75
1.0	9	3.15	+.02	7.00	-.24	9.50	-.53
1.0	10	2.30	+.07	5.20	-.12	7.22	-.35
1.0	11	1.60	+.10	3.65	+.01	5.18	-.18
1.0	12	1.00	+.11	2.40	+.08	3.40	-.02
1.0	13	.60	+.10	1.50	+.12	2.05	+.08
1.0	14	.15	+.09	.62	+.13	.90	+.11
1.0	15	.01	+.05	.18	+.10	.29	+.10
0.7	16	.00	+.02	.00	+.05	.01	+.05
		c ^ε _{ij} = 12.57		c ^ε _{ij} = 25.15		c ^ε _{ij} = 33.55	
		j = 45° / 20"		j = 45° / 20"		j = 45° / 20"	

Table 8a

Influence Coefficients

v^ε_{ij} = Inches Deflection/Pound × 10³

m^ε_{ij} = Inches Deflection/Inch Pound × 10³

c^ε_{ij} = Inches Deflection/Pound × 10³

Sector Angle = 45°, t = 1/8 Inches, Radius = 20 Inches

Material--24 ST Aluminum Alloy

$$W_i = \left\{ \sum_{j=1}^{15} V(j) \cdot v_{ij}^{\epsilon} + .71V_i(16) v_{i(16)}^{\epsilon} + \sum_{j=1}^{15} M(j) m_{ij}^{\epsilon} + \dots \right. \\ \left. + .7 M_{(16)} m_{i(16)}^{\epsilon} + P c_{ij}^{\epsilon} \right\} \times 10^3$$

		i = 45°/20"		i = 30°/20"		i = 40°/20"	
S	j	v _{ij} ^ξ	m _{ij} ^ξ	v _{ij} ^ξ	m _{ij} ^ξ	v _{ij} ^ξ	m _{ij} ^ξ
1.0	1	40.25	-3.92	35.00	-3.42	22.90	-2.24
1.0	2	36.70	-3.48	32.70	-3.27	22.15	-2.20
1.0	3	33.05	-3.02	30.10	-2.98	21.25	-2.17
1.0	4	29.37	-2.58	27.25	-2.62	20.25	-2.16
1.0	5	25.70	-2.14	24.20	-2.23	19.05	-2.16
1.0	6	22.05	-1.76	21.10	-1.87	17.40	-2.07
1.0	7	18.60	-1.40	18.00	-1.54	15.40	-1.75
1.0	8	15.35	-1.07	14.95	-1.22	13.20	-1.44
1.0	9	12.05	- .78	11.90	- .92	10.90	-1.15
1.0	10	9.00	- .51	9.00	- .64	8.60	- .80
1.0	11	6.42	- .28	6.50	- .40	6.45	- .61
1.0	12	4.30	- .10	4.50	- .18	4.50	- .34
1.0	13	2.50	+ .04	2.90	+ .00	2.60	- .11
1.0	14	1.25	+ .12	1.20	+ .10	1.20	+ .02
1.0	15	.40	+ .12	.35	+ .10	.35	+ .08
0.7	16	.01	+ .05	.01	+ .04	.01	+ .07
		c _{ij} ^ξ = 42.05 j = 45° / 20"		c _{ij} ^ξ = 35.98 j = 45° / 20"		c _{ij} ^ξ = 23.15 j = 45° / 20"	

Table 8b

Influence Coefficients

$$v_{ij}^{\xi} = \text{Inches Deflection/Pound} \times 10^3$$

$$m_{ij}^{\xi} = \text{Inches Deflection/Inch Pound} \times 10^3$$

$$c_{ij}^{\xi} = \text{Inches Deflection/Pound} \times 10^3$$

Sector Angle = 45°/20", t = 1/8 Inches, Radius = 20 Inches

$$W_i = \left\{ \sum_{j=1}^{15} [V(j) v_{ij}^{\xi}] + .7/ V(16) v_{i(16)}^{\xi} + \sum_{j=1}^{15} [M(j) m_{ij}^{\xi}] + \dots \right. \\ \left. + .7/ M(16) m_{i(16)}^{\xi} + P c_{ij}^{\xi} \right\} \times 10^3$$

Load at

	45°/16"	45°/18"	45°/20"	30°/20"	15°/20"
Meter at 45°/16"	7.30*				
45°/18"	7.34	7.35			
45°/20"	7.26	7.30	7.39		
30°/20"	7.23	7.34	7.29	7.31	
15°/20"	7.29	7.32	7.16	7.19	7.26

* Influence Coefficients .125 inch Sector
Influence Coefficient .251 inch Sector

TABLE 9
Effect of Thickness
on Stiffness

Deg.	In.	{A}75°
15	6	5.5850
15	10	10.4720
15	14	14.6608
15	20	0.0000
30	12	19.7804
30	16	21.4672
30	20	14.1368
45	6	5.5850
45	10	10.4720
45	14	14.6608
45	18	18.8491
45	20	0.0000
60	8	10.5418
60	12	12.5664
60	16	16.7550
60	20	9.4246
75	14	1.6755
75	6	0.0000
75	8	4.2936
75	10	0.0000
75	12	6.2832
75	14	0.0000
75	16	8.3775
75	18	0.0000
75	20	4.7123

Deg.	In.	{A}60°
15	6	5.5850
15	10	10.4720
15	14	14.6608
20	20	0.0000
30	12	19.7804
30	16	21.4672
30	20	14.1368
45	6	5.5850
45	10	10.4720
45	14	14.6608
45	18	18.8491
45	20	0.0000
60	4	0.0000
60	6	0.0000
60	8	5.4105
60	10	0.0000
60	12	6.2832
60	14	0.0000
60	16	8.3775
60	18	0.0000
60	20	4.7123

Deg.	In.	{A}45°
7.5	20	1.9897
15	6	8.1214
15	10	10.2427
15	14	10.4720
15	16	8.3776
15	18	8.4300
15	20	3.9794
22.5	20	1.9897
30	8	7.3396
30	12	8.9010
30	14	7.3304
30	16	8.3776
30	18	8.4300
30	20	3.9794
37.5	20	1.9897
45	4	3.1027
45	6	2.9125
45	8	2.0944
45	10	2.6170
45	12	3.1416
45	14	3.6652
45	16	4.1888
45	18	4.2150
45	20	1.9897

TABLE 10

Column Matrices of Area Coefficients*

for

Sectors of 20 Inch Radius

*Inches² / Point

Deg./In.	$\{A\}_{180^\circ}$
15/6	5.5850
15/10	10.4720
15/14	14.6608
15/20	0.0000
30/12	19.7804
30/16	21.4672
30/20	14.1368
45/6	5.5850
45/10	10.4720
45/14	14.6608
45/18	18.8491
45/20	0.0000
60/8	13.0550
60/12	12.5664
60/16	16.7550
60/20	9.4246
75/10	10.4720
75/14	14.6608
75/18	18.8491
75/20	0.0000
90/4	5.4454
90/8	10.6814
90/12	12.5664
90/16	16.7550
90/20	9.4246
105/6	6.2832
105/10	10.4720
105/14	14.6608
105/18	18.8491
120/8	13.4041
120/12	12.5664
120/16	16.7550
120/20	9.4246
135/8	10.4720
135/12	14.6608
135/16	18.8491
135/20	0.0000
150/4	5.4454
150/8	10.6814
150/12	12.5664
150/16	16.7550
150/20	9.4246
165/6	6.2832
165/10	10.4720
165/14	14.6608
165/18	18.8491
165/20	0.0000
180/12	10.1230
180/14	0.0000
180/16	8.3775
180/18	0.0000
180/20	4.7123

Deg./In.	$\{A\}_{135^\circ}$
15/6	5.5850
15/10	10.4720
15/14	14.6608
15/20	0.0000
30/12	19.7804
30/16	21.4672
30/20	14.1368
45/6	5.5850
45/10	10.4720
45/14	14.6608
45/18	18.8491
45/20	0.0000
60/8	13.0550
60/12	12.5664
60/16	16.7550
60/20	9.4246
75/10	10.4720
75/14	14.6608
75/18	18.8491
75/20	0.0000
90/4	5.4454
90/8	10.6814
90/12	12.5664
90/16	16.7550
90/20	9.4246
105/6	6.2832
105/10	10.4720
105/14	14.6608
105/18	18.8491
120/8	10.8909
120/12	12.5664
120/16	16.7550
120/20	9.4246
135/4	1.6755
135/6	0.0000
135/8	4.2935
135/10	0.0000
135/12	6.2832
135/14	0.0000
135/16	8.3775
135/18	0.0000
135/20	4.7123

Deg./In.	$\{A\}_{90^\circ}$
15/6	5.5850
15/10	10.4720
15/14	14.6608
15/20	0.0000
30/12	19.7804
30/16	21.4672
30/20	14.1368
45/6	5.5850
45/10	10.4720
45/14	14.6608
45/18	18.8491
45/20	0.0000
60/8	13.0550
60/12	12.5664
60/16	16.7550
60/20	9.4246
75/10	10.4720
75/14	14.6608
75/18	18.8491
75/20	0.0000
90/4	3.3510
90/6	0.0000
90/8	5.9690
90/10	0.0000
90/12	6.2832
90/14	0.0000
90/16	8.3775
90/18	0.0000
90/20	4.1723

TABLE 11

Column Matrices of Area Coefficients*
for
Sectors of 20 Inch Radius

*Inches² / Point

ILLUSTRATIONS

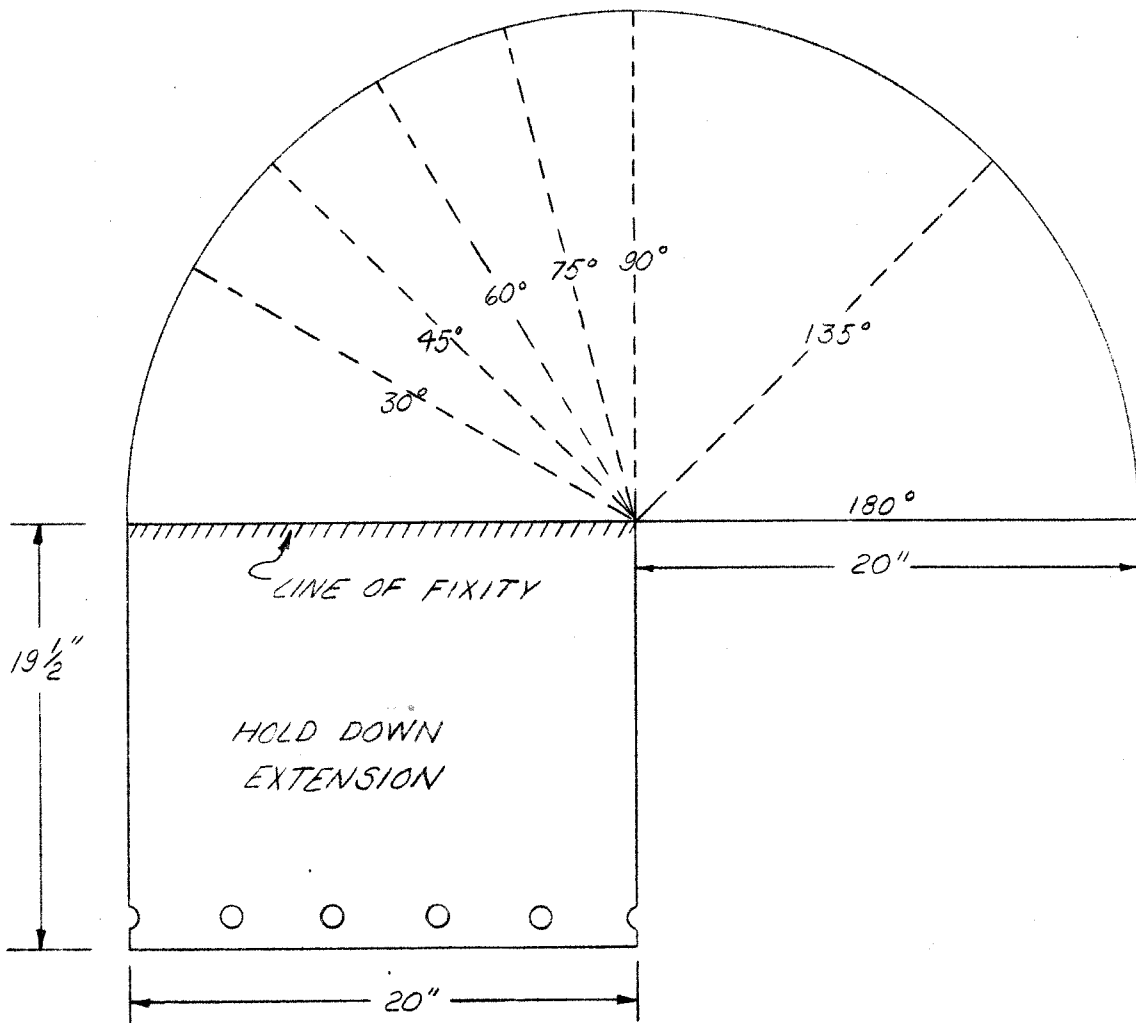

FIG. 1
PLAN FORM OF PHASE I SPECIMEN
1/4" 24 ST ALUMINUM ALLOY

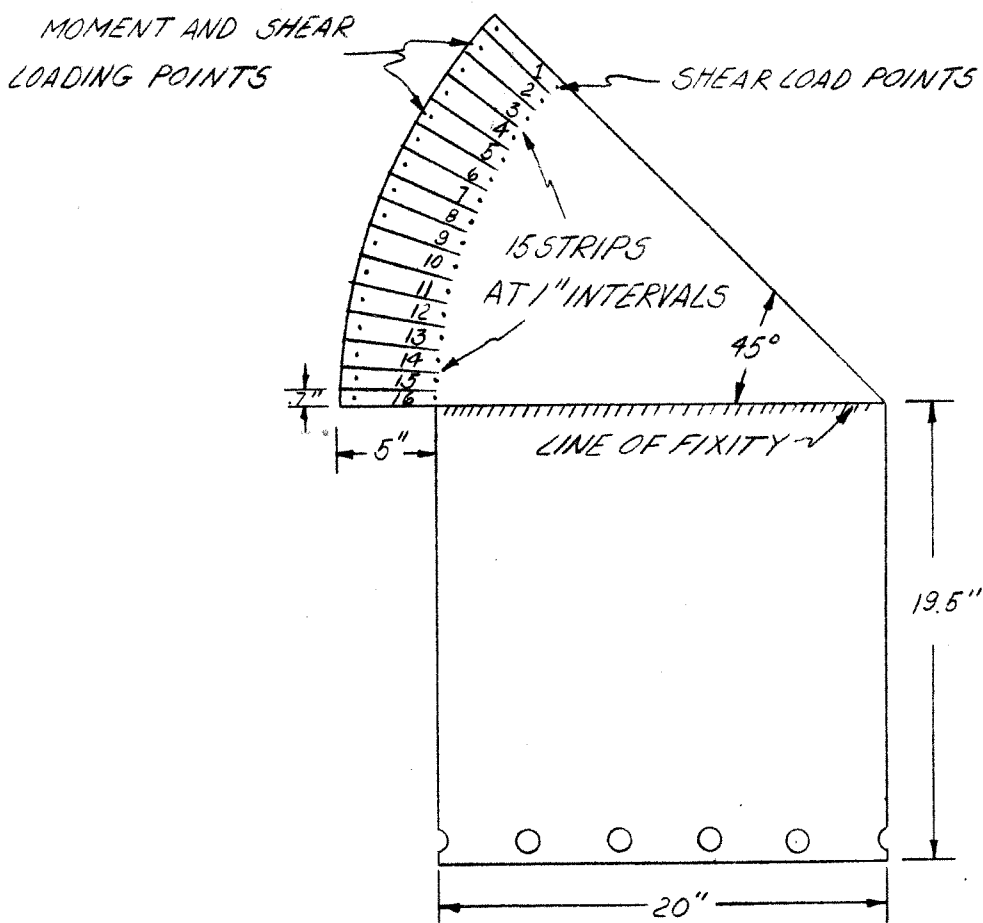

FIG. 2
PLAN FORM OF PHASE 2 SPECIMEN
1/8" 24 ST ALUMINUM ALLOY

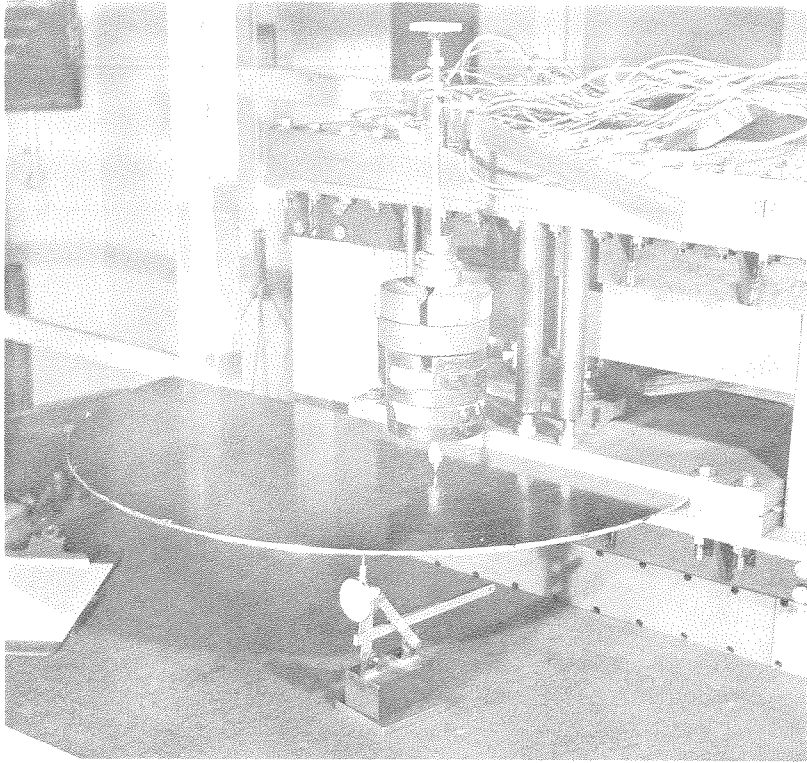

Figure 3

Arrangement for securing specimen

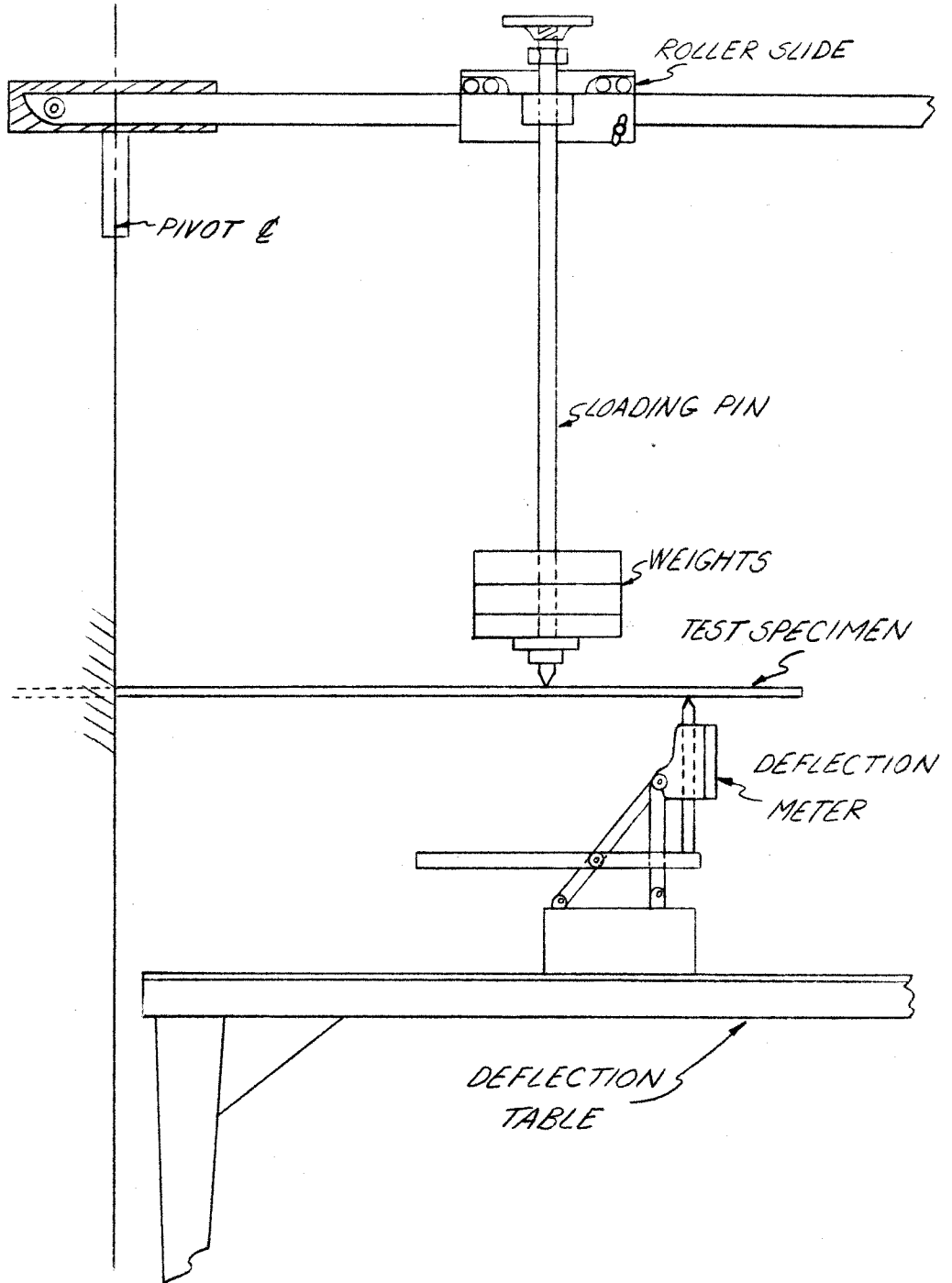

FIG. 4

ARRANGEMENT FOR LOADING
AND MEASURING DEFLECTIONS
OF TEST SPECIMEN

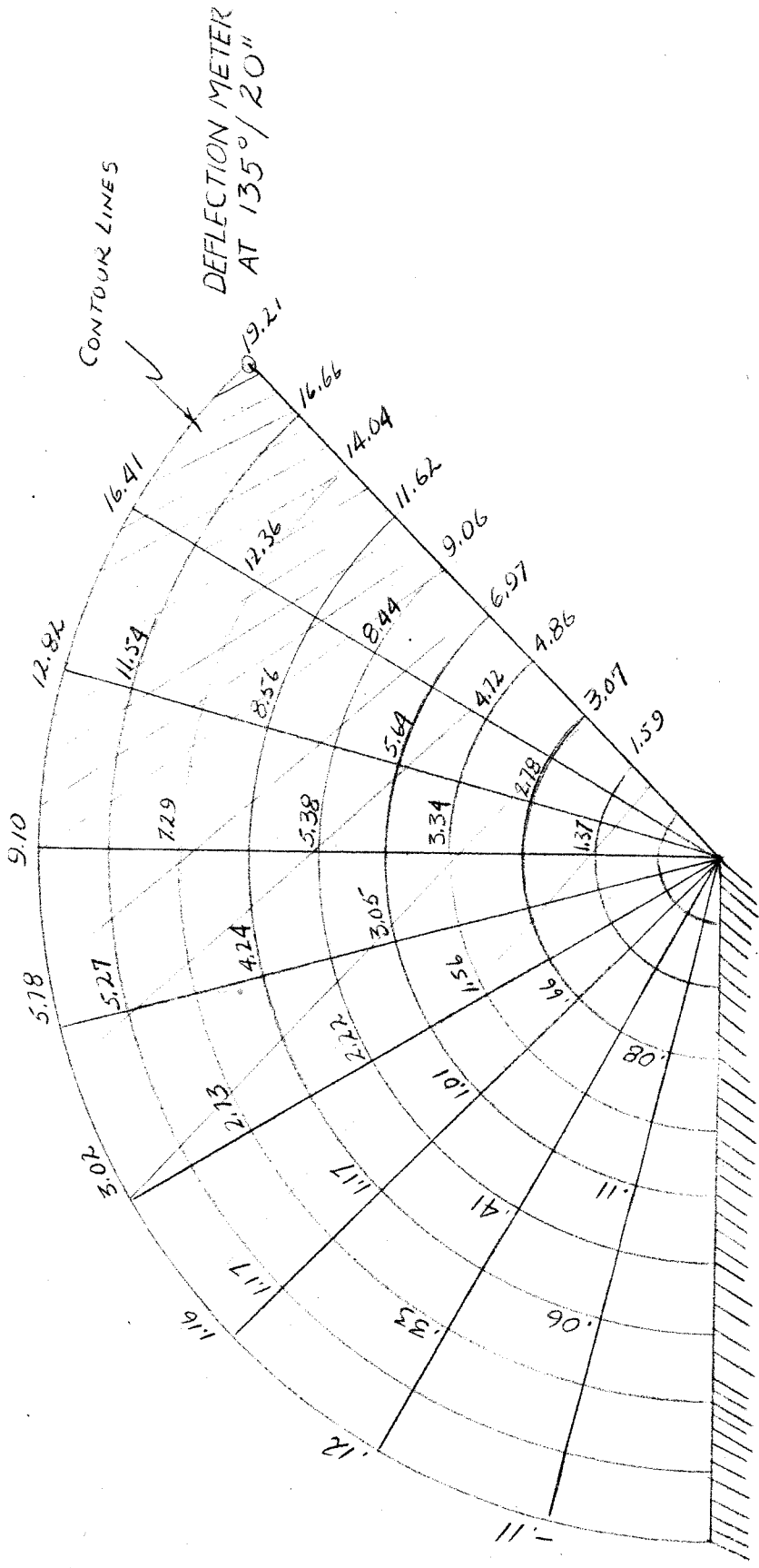

FIG. 5
SAMPLE DATA SHEET

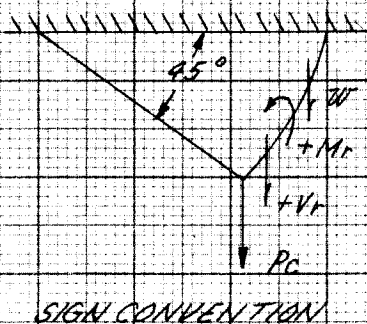
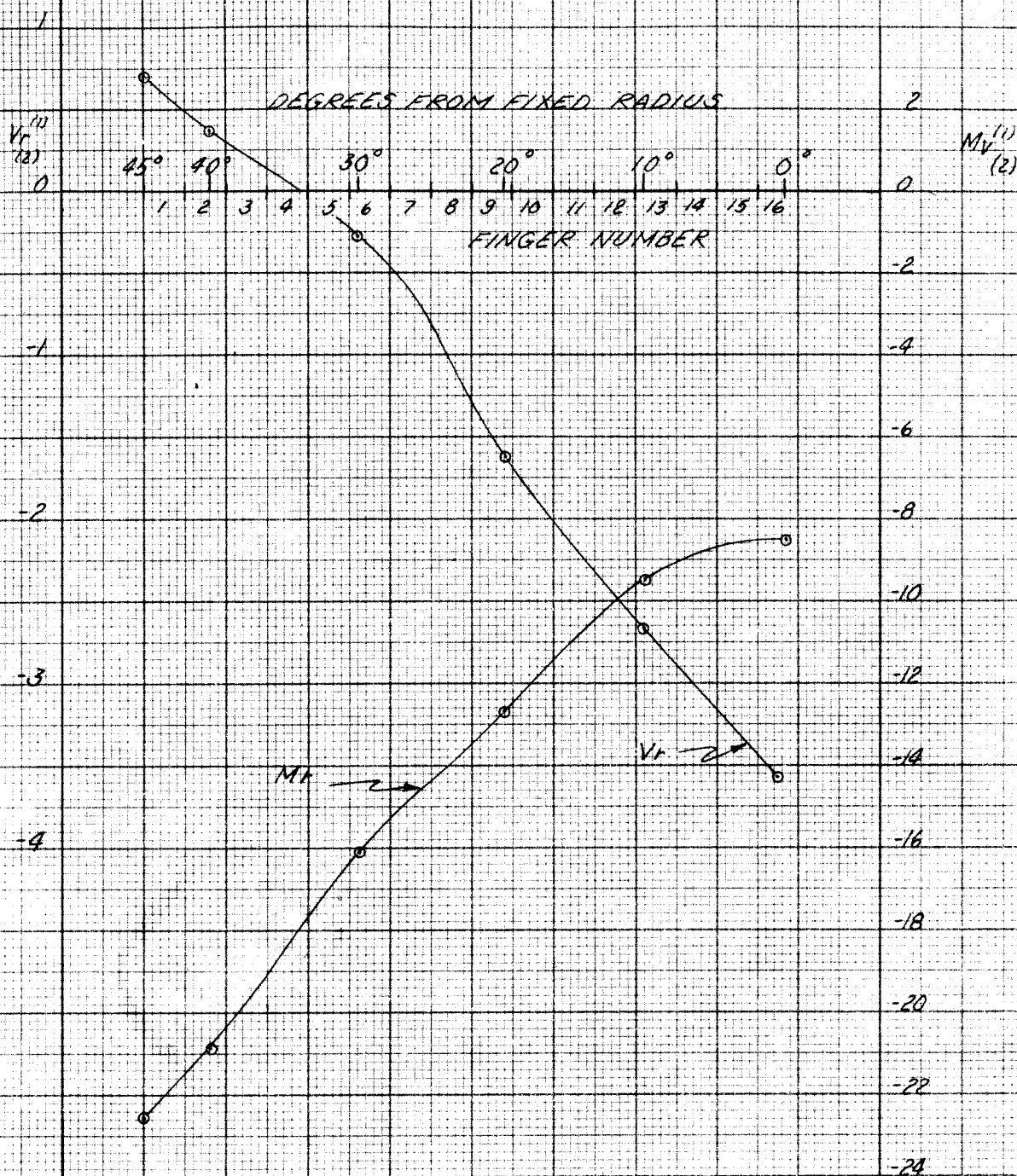

FIG. 6
 ARC BOUNDARY LOADING
 CONDITION NO. 1
 $M_v \sim$ INCH POUNDS PER INCH
 $V_r \sim$ POUNDS PER INCH
 $P_c = 14.58$ POUNDS

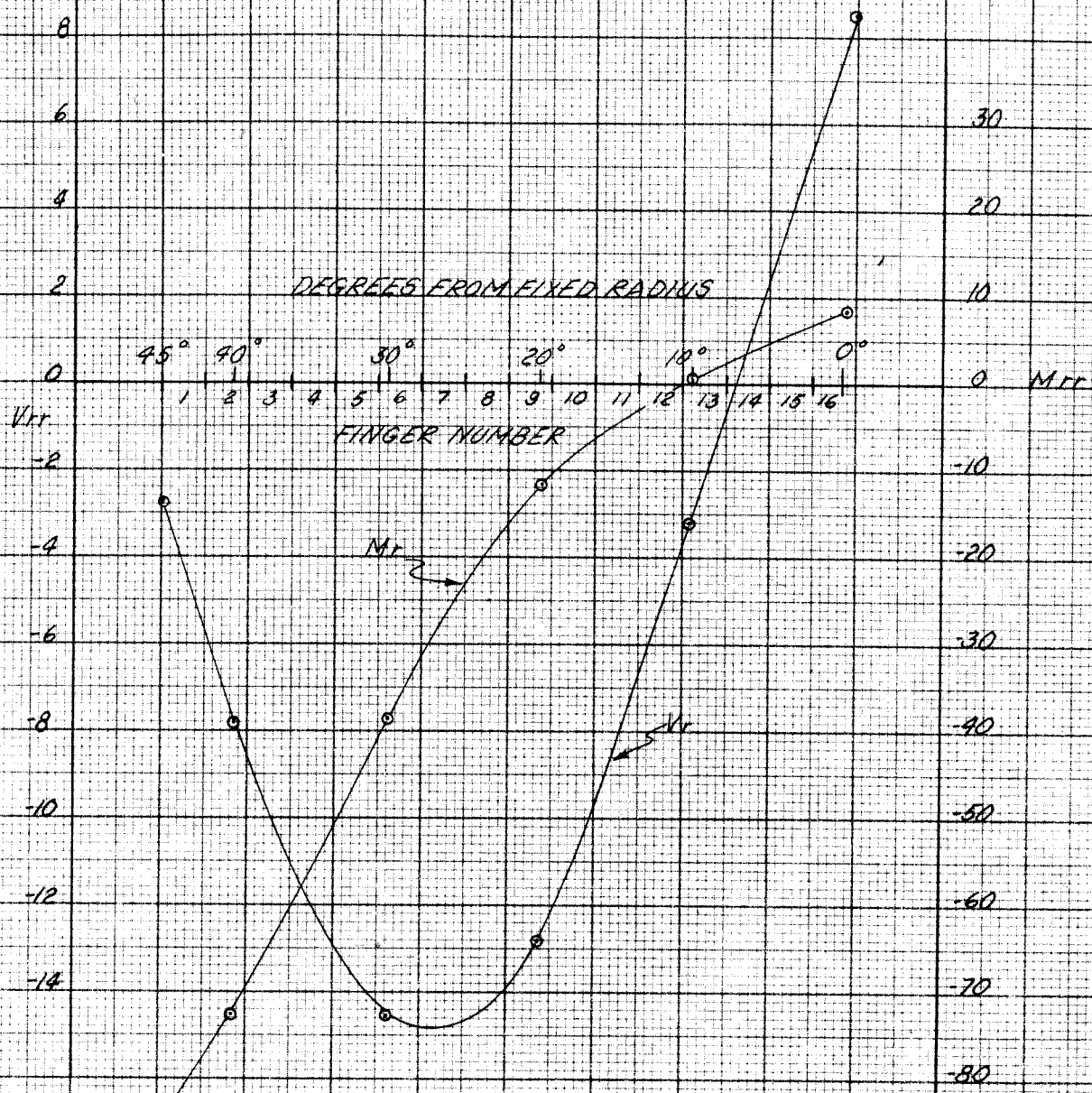
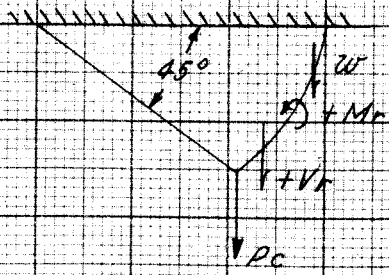

FIG 7

ARC BOUNDARY LOADING
CONDITION NO. 3

M_r ~ INCH POUNDS PER INCH
 V_r ~ POUNDS PER INCH
 $P_c = 55.34$ POUNDS



SIGN CONVENTION

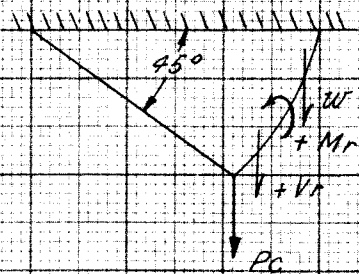
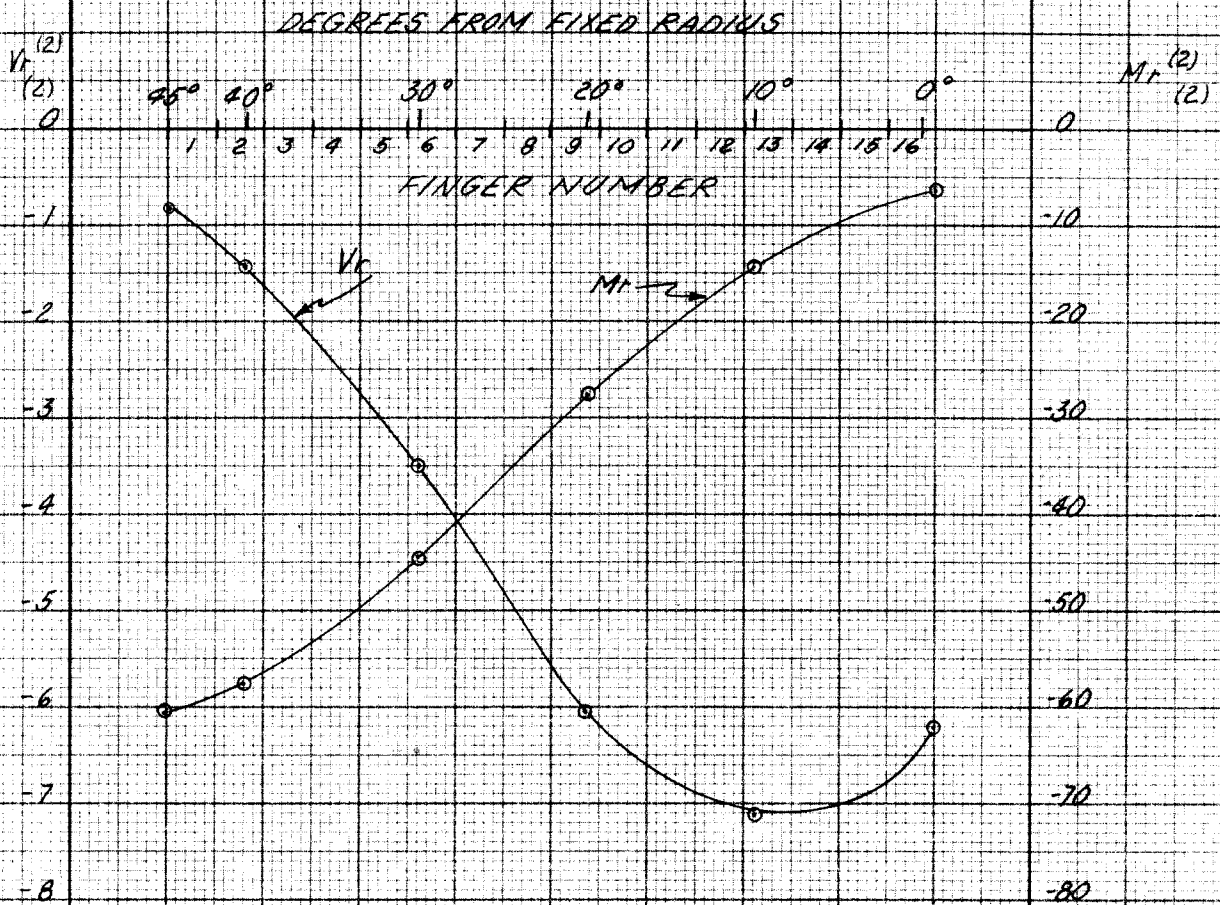

SIGN CONVENTION

FIG. 5

ARC BOUNDARY LOADING
 CONDITION NO. 2
 $M_r \sim$ INCH POUNDS PER INCH
 $V_r \sim$ POUNDS PER INCH
 $P_c = 13.79$ POUNDS

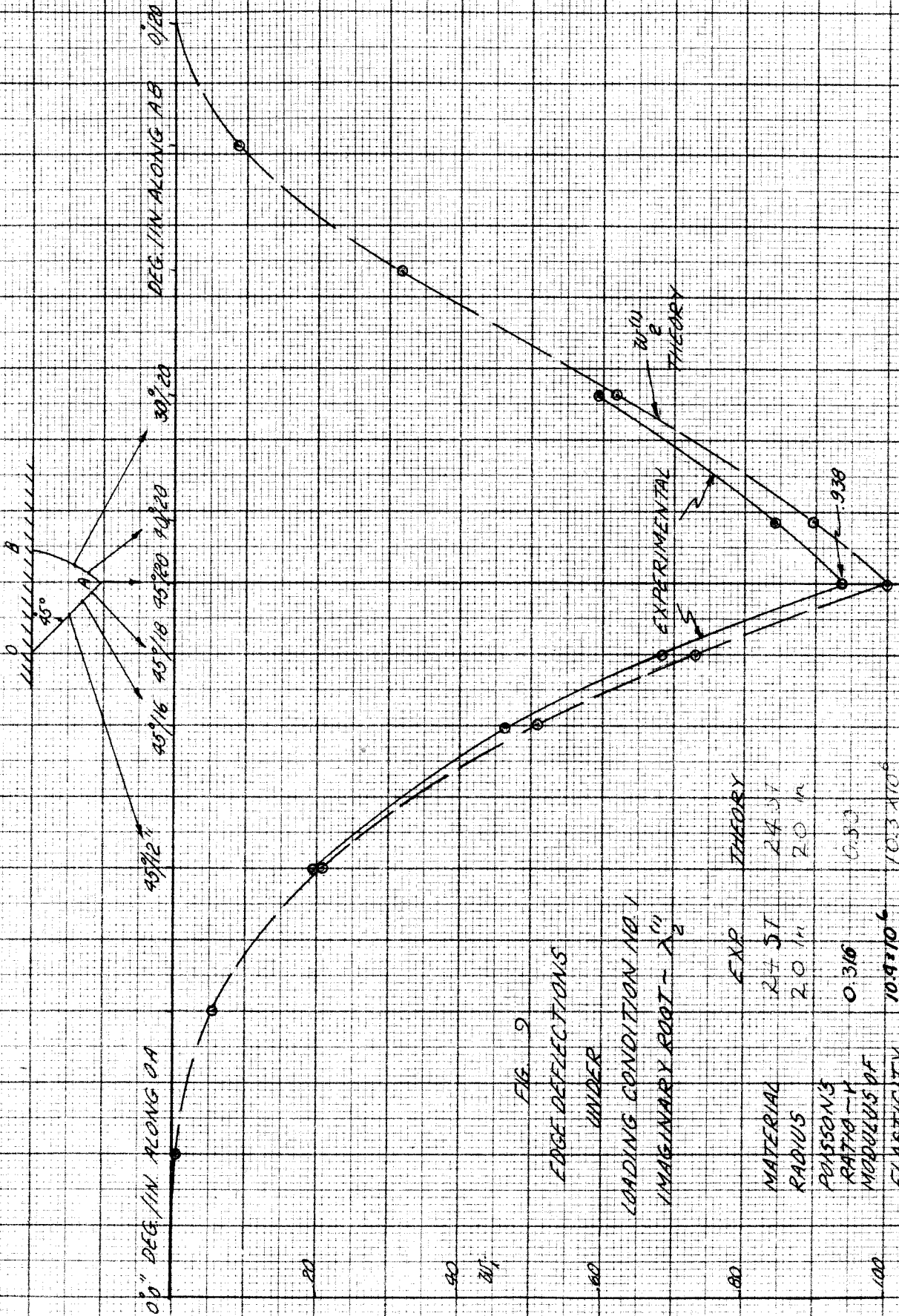

FIG. 9

EDGE DEFLECTIONS

UNDER

LOADING CONDITION NO. 1

IMAGINARY ROOT - λ_2

	EXP	THEORY
MATERIAL	24 ST	24 ST
RADIUS	2.0 IN	2.0 IN
POISSON'S RATIO - μ	0.316	0.33
MODULUS OF ELASTICITY	109,710 ⁶	103,170 ⁶

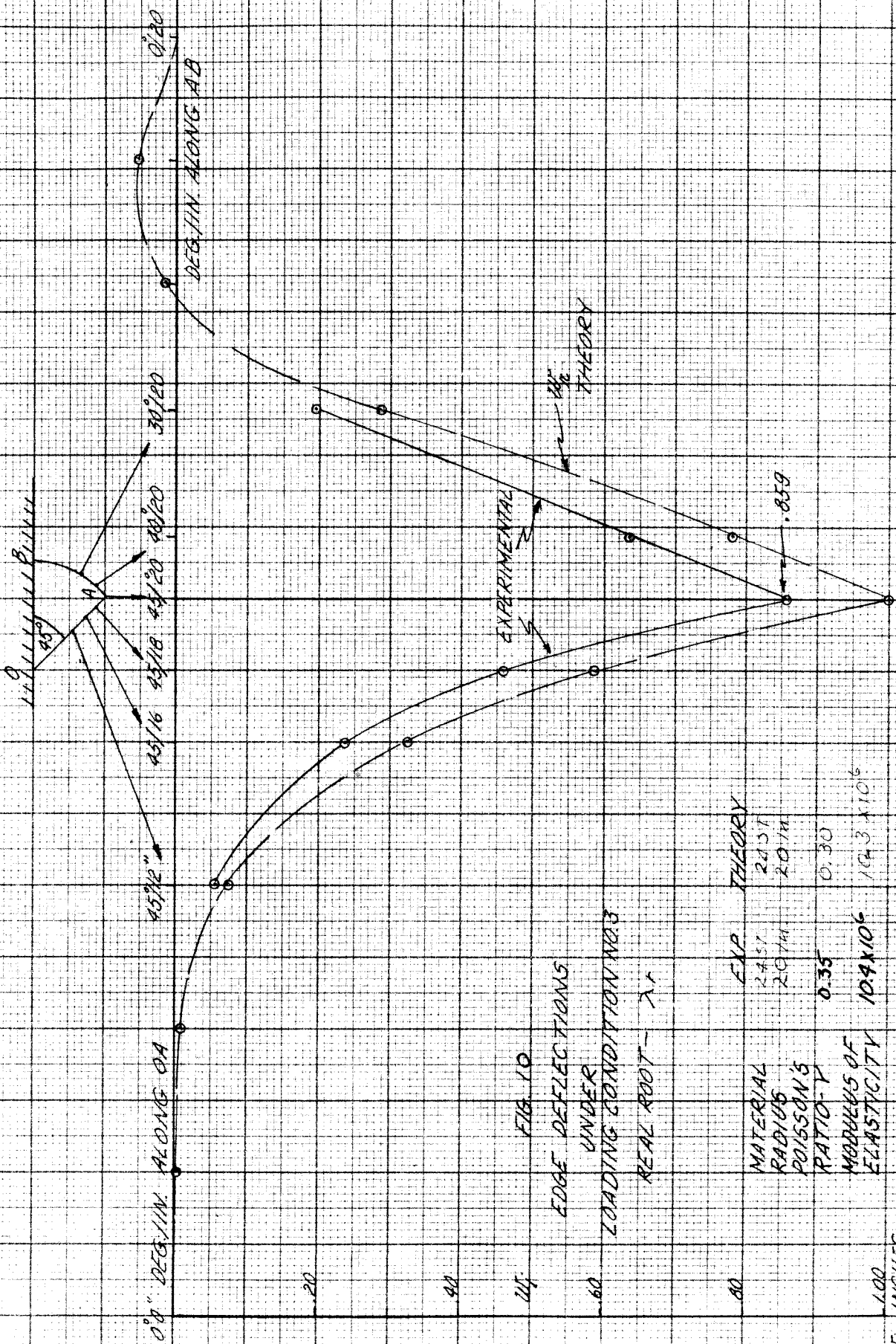

FIG. 10
EDGE DEFLECTIONS
UNDER
LOADING CONDITION NO. 3
REAL ROOT - λ

MATERIAL RADIUS	EXP	THEORY
24.57	24.57	20.51
20.74	20.74	20.74
POISSON'S RATIO - ν	0.35	0.30
MODULUS OF ELASTICITY	10.9×10^6	10.3×10^6

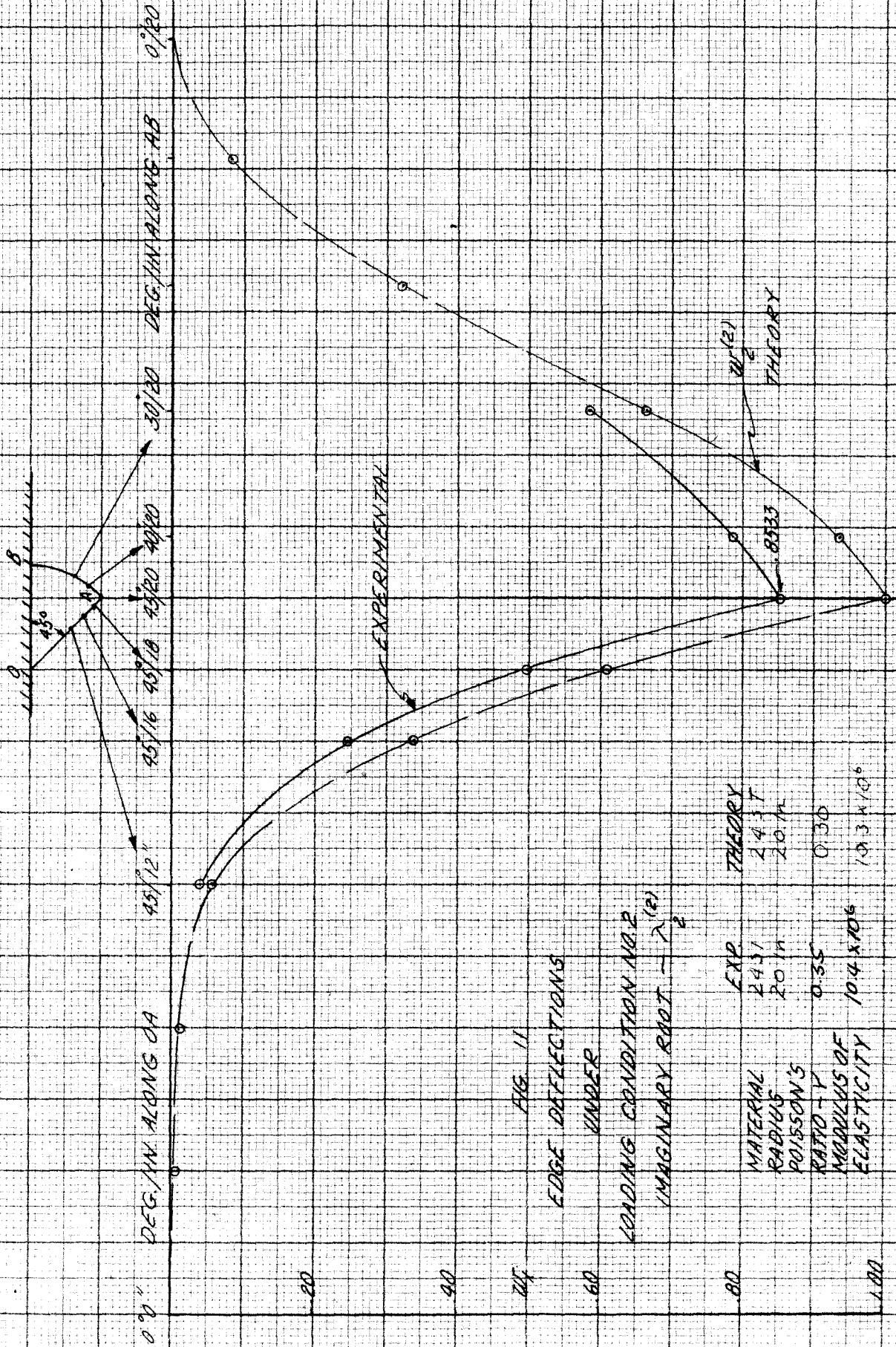

FIG. 11

EDGE DEFLECTIONS

UNDER

BENDING CONDITION NO. 2

IMAGINARY ROOT - $\sqrt{\frac{1}{2}}$

W - INCHES

APPENDIX

SAMPLE CALCULATIONS

Influence Coefficients (Normal Concentrated Loading).

Let $w_i \equiv$ Deflection in inches at deflection point "i".

$P_j \equiv$ Concentrated load in pounds at load point "j".

= 50 pounds (Phase 1).

= 10 pounds (Phase 2).

$\xi_{ij} \equiv$ Influence coefficient in inches / 1000 pounds.

= [Inches def. (at "i") per lb (at "j")] $\times 10^3$.

$$w_{ij} = P_j \xi_{ij} \times 10^{-3} \quad 1:1$$

$$\xi_{ij} = 20 w_{ij} \quad (\text{Phase 1}) \quad 1:2$$

$$\xi_{ij} = 100 w_{ij} \quad (\text{Phase 2}) \quad 1:3$$

In the experimental procedure used the dial gauge was set to read zero with the load off and, therefore, read w_{ij} when the load was applied. The simple multiplication involved made possible the recording of ξ_{ij} directly.

Influence Coefficients (Shear Loading along Boundary).

Let $w_i \equiv$ Deflection in inches at "i". (Phase 2).

$V_j \equiv$ Shear in pounds / inch on boundary near "j".

$v\xi_{ij} \equiv$ Influence coefficient in inches / 1000 pounds.

= [Inches deflection (at "i") per pound near "j"] $\times 10^3$.

$s =$ Boundary length of element near "j".

$$w_{ij} = s(V_j v\xi_{ij}) \times 10^{-3} \quad 2:1$$

For 10 pound load and fingers 1" wide at root.

$$w_{ij} = \frac{\xi_{ij}}{100} \quad (\text{Finger No. 1-15})$$

$$\xi_{ij} = w_{ij} \times 100 \quad 2:2$$

For 10 pound load and finger .71" wide at root.

$$w_{i(16)} = 0.71 \left(\frac{10}{.71} v \epsilon_{i(16)} \right) \times 10^{-3} \quad (\text{Finger No. 16})$$

$$\epsilon_{i(16)} = w_{ij} \times 100 \quad 2:3$$

By superposition, for the specific case of Phase 2 the deflection at any point "i" due to a distributed shear load on the boundary is given by:

$$v w_i = \sum_{j=1}^{15} V_j \epsilon_{ij} \times 10^{-3} + 0.71 V_{(16)} \epsilon_{i(16)} \times 10^{-3} \quad 2:1a$$

Equations 2:2 and 2:3 indicate that the influence coefficients are independent of the width of the fingers. However, 2:1a illustrates how the width of the finger is used when calculating deflections by the use of influence coefficients.

Influence Coefficients (Radial Moment on Free Boundary).

Let $w_i \equiv$ Deflection in inches at "i".

$M_j \equiv$ Radial Moment in inches / lb / inch near "j".

$= 49.9$ inch pounds / in. (Phase 2).

$m \epsilon_{ij} \equiv$ Influence coefficient in inches deflection per 1000

inch pounds / inch / inch.

$=$ [Inches deflection at "i" per inch pound near "j"] $\times 10^3$.

For 10.4 pound load 4.8 inches from root of 1" fingers.

$$w_{ij} = s(V_j v \epsilon_{ij} + M_j m \epsilon_{ij}) \times 10^{-3} \quad 3:1$$

$$= 1.0(10.4 v \epsilon_{ij} + 49.9 m \epsilon_{ij}) \times 10^{-3} \quad (\text{Fingers 1-15}) \quad 3:1a$$

$$= 0.71 \left(\frac{10.4}{.71} v \epsilon_{i(16)} + \frac{49.9}{.7} m \epsilon_{i(16)} \right) \times 10^{-3} \quad (\text{Finger 16}) \quad 3:1b$$

$$m \epsilon_{ij} = \frac{w_{ij} \times 10^{-3} - 10.4 v \epsilon_{ij}}{49.9} \quad (\text{Fingers 1-16}) \quad 3:2$$