

AN EVALUATION OF THE TENSION IMPACT TEST
BY CORRELATION WITH
THE PHYSICAL PROPERTIES OF ALUMINUM ALLOYS

Thesis

By

Lieut. W. B. Mechling, U. S. N.

and

Capt. S. S. Jack, U. S. M. C.

In Partial Fulfillment of
The Requirements for the Degree of
Master of Science in Aeronautical Engineering

California Institute of Technology

Pasadena, California

1938

ACKNOWLEDGMENT

In completing the investigation the authors are indebted to the staff of the Guggenheim Aeronautical Laboratory, California Institute of Technology; the Douglas Aircraft Company, which supplied the test specimens; and to the personnel of the materials testing laboratory of that company, who conducted certain of the tests.

In particular they wish to thank Dr. Th. von Karman, Director of the Laboratory; Dr. E. E. Sechler, under whose direction the research was carried out; and Mr. H. V. Pavlecka, of the Douglas Aircraft Company.

TABLE OF CONTENTS

	Page
Introduction	1
Tension Impact Testing	2
Test Procedure	9
Aluminum Alloy 14S-T	14
Aluminum Alloy 24S-T	17

INTRODUCTION

In an endeavor to evaluate the Tension Impact Test and to correlate results, it was necessary to conduct the test upon material whose exact physical properties were known. It was decided to employ the aluminum alloys used in aircraft manufacture for this purpose as a complete investigation of their properties had not been made available to the industry. Thus the routine tests conducted for correlation purposes have an added value in that they present further data on these alloys.

The following alloys were therefore chosen as being appropriate materials upon which to conduct this investigation:

14S-T A forging alloy

24S-T A wrought alloy

This report naturally divides itself into two sections:

(a) The investigation of Tension Impact Testing.

(b) The results of tests conducted upon the above aluminum alloys.

TENSION IMPACT TESTING

Before the investigation of the physical properties of the aluminum alloys was begun, a study of the value and method of tension impact testing was made. In a survey of available literature on this subject, it was found that Mr. H. C. Mann, of Watertown Arsenal, had carried out an extensive program of tension impact testing on ferrous materials. Because of its importance and relevance to the authors' problem, a brief summary of his conclusions is given (Ref. 1).

He believes that these tests give a better index of the ability of a material to absorb dynamic loads than does the standard Izod or Charpy Test, mainly because they can be correlated with the Static Tension Test. He states that the mechanism and process of deformation are essentially the same under both static and dynamic conditions. This is shown by the fact that approximately the same amount of energy is used to rupture similar specimens in both static and dynamic tests and that there is similar elongation and reduction of area in the specimen. However, during the process of rupturing, a material shows an increased

elastic strength accounted for by an apparent conversion of inherent potential energy to inherent kinetic energy. A factor based upon this apparent energy transfer is applied to the energy indicated by the load-deformation curves obtained in a static test in order to effect correlation with the dynamic test.

This correction is made in the following manner. The static tension test is carried out in the usual manner except that total elongation is measured and plotted against total load. The test is stopped at appropriate load increments and the cross section area of the most reduced section is measured. The ratio of the original cross section area to that of the most reduced section is multiplied by the actual load on the specimen at the time of measurement, this corrected load ordinate then being plotted against the deformation. This procedure is continued until failure occurs. The area under the normal load-deformation curve represents the external work or energy. The area between the normal and the corrected curve is equal to the inherent energy of the material. The sum of the two areas or the total area under the corrected curve gives the total energy of rupture.

He further states that this so-called inherent potential energy is a specific property of a material and that the material fails when it is all converted into inherent kinetic energy. He conducted tests and took careful measurements on a considerable number of ferrous materials, and by computing energy absorbed in the static tests as outlined above, obtained excellent agreement with the dynamic tests.

Mann's tests also indicate that a material possesses a limiting rate of rupture for maximum energy absorption. If this rate is exceeded, i.e., the velocity of impact exceeds some critical value, then the energy absorbed is reduced. The critical rate of impact for 1035 steel was shown to be about 30 ft./sec. As the Tinius-Olsen machine used in this investigation has a maximum striking velocity of 11.35 ft./sec. no investigation of the effects of velocity of impact could be undertaken although such would be desirable. It is probable that the impact values obtained for both steel and aluminum were maximums as the impact velocity is well below the limiting rate for steel.

In order to get more complete information on proper testing technique, the authors conducted a series of tension impact tests to determine the effect of surface finish and of specimen diameter. The equipment available for this was a standard pendulum type, 120 ft. lb. Tinius-Olsen Impact Testing Machine with a maximum striking velocity of 11.35 ft./sec., designed for standard Izod testing. The fixed anvil was modified to hold a tension impact specimen horizontally and in such a position that the hammer would strike the movable anvil at the exact bottom of its stroke (Figure 1). The determination of energy absorbed in breaking the specimen was made in the normal manner. The specimens were machined from 5/8" round bar stock of normalized 1040 steel with surface conditions varying through four grades: rough machine, smooth machine, ground, and ground and polished. The effect of surface roughness is shown in Figure 2. This is based on energy absorbed for a single diameter specimen. However, approximately the same magnitude of scatter and lack of any specific trend held for all diameters tested. The results on the roughly machined specimens are not shown as they were very erratic and the roughness was artificially obtained by the use of

an especially dulled tool. From the data as shown, it appears that nothing is to be gained by extreme refinement in surface finish.

A series of tests were made using the following specimen diameters: 0.10", 0.15", 0.20", 0.22", and 0.25". The average value of the unit energy (ft. lbs./cu. in.) for the various diameters is plotted in Figure 3, each average being based on fifteen specimens. A definite drop in unit energy is noted for the smaller diameters. This is probably due to a hardened and embrittled surface layer formed as a result of the cold working of the material during machining. Naturally, as the diameter increases, this effect becomes of less importance and it is probable that specimens above 0.25" diameter would give practically constant unit energy. Data from Reference 1, shows that a 1040 steel specimen of 0.357" diameter absorbed the same unit energy as did the 0.25" diameter specimens tested by the authors. Greater diameters were not investigated because of the limited capacity of the testing equipment.

The project for the testing of the physical properties of the aluminum alloys included fifteen extra specimens of the tension impact type, manufactured from the same stock. These will be available for an

investigation of tension impact fatigue upon the development of a machine for that type testing. This machine will deliver repeated blows of a predetermined energy input to the specimen. The specimen should be able to withstand an infinite number of blows if the energy of each blow is entirely absorbed in elastic deformation and the limit for energy absorption by this means should denote the fatigue strength of the material. Any energy input above this limiting value must be absorbed in plastic deformation of the specimen and repeated blows should cause its failure. It is hoped that there may be some correlation between the total energy absorbed in plastic deformation before failure and the energy absorbed in the tension impact test.

Discussion of Results

The method of impact testing using a tension specimen is believed to give a good measure of a material's ability to withstand dynamic loads. The test results obtained by the authors indicate that small inaccuracies in the manufacture of the specimens do not materially affect the test values. The results also indicate that specimens of any given material having diameters of 0.25" or over absorb practically

constant unit energy. This would signify that a basic property of the material is being measured.

The notched type impact test has been correctly called a "notch sensitivity" test in that it indicates a material's ability to absorb a dynamic load in bending when the tension side of the specimen contains a sharp groove or notch. These tests show a variation in impact strength with grain direction but in a different degree from that obtained in tension impact tests. They also indicate that there may be a variation in notch sensitivity with change in the plane of the notch while maintaining the same longitudinal axis of the specimen. The results of these tests are vitally affected by small variations in the specimens themselves. Any variation in the dimensions of the specimens or in the shape, depth or width of the notch affects the results so markedly that they become practically useless for comparative purposes.

The two types of impact test are seen to demonstrate different inherent characteristics of a material. It is therefore believed that any complete investigation of the physical properties of a given material should include both tension and notched type impact tests.

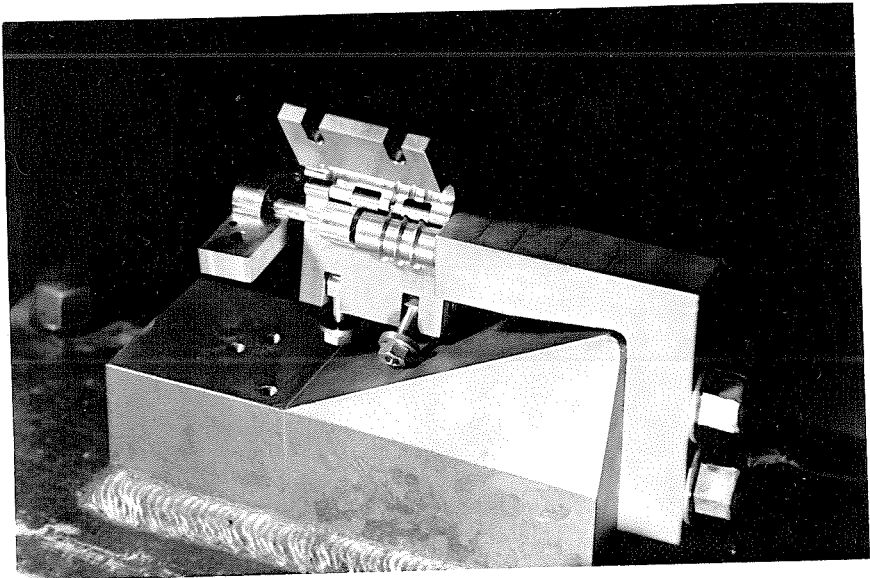
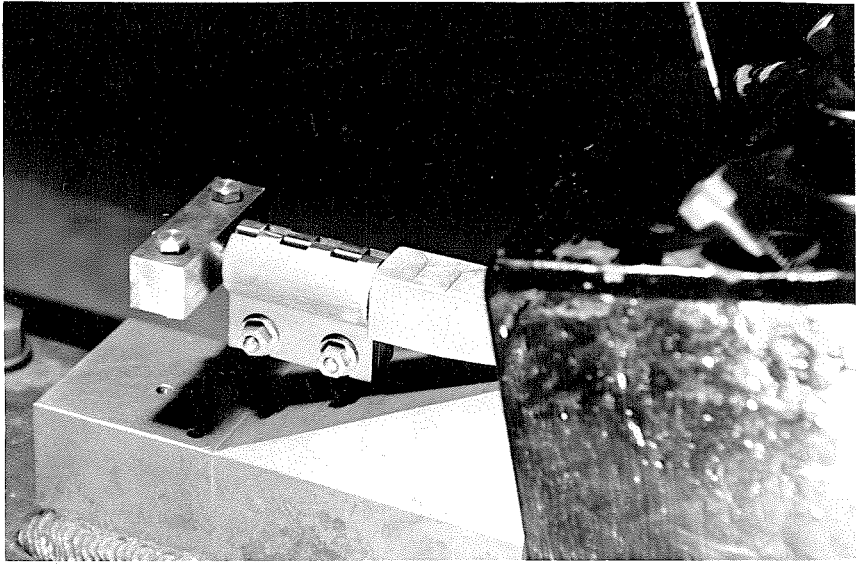

Figure 1

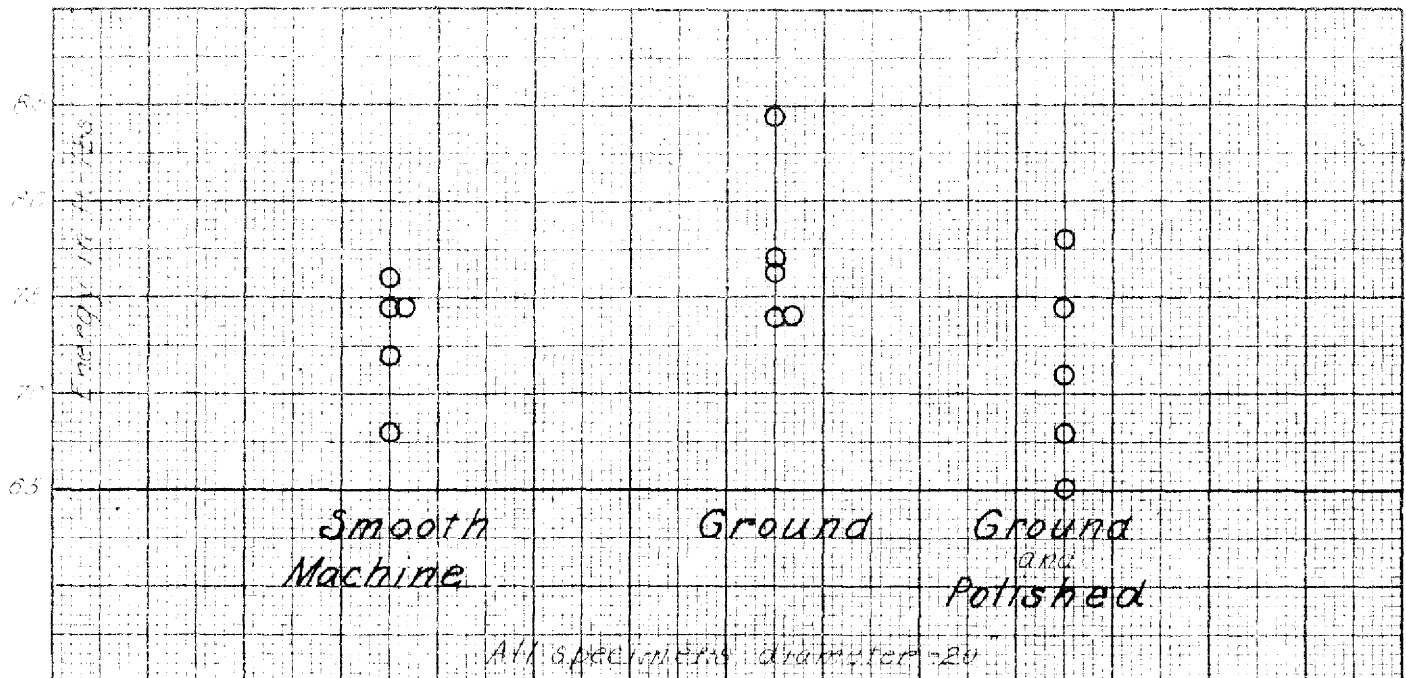

Figure 2

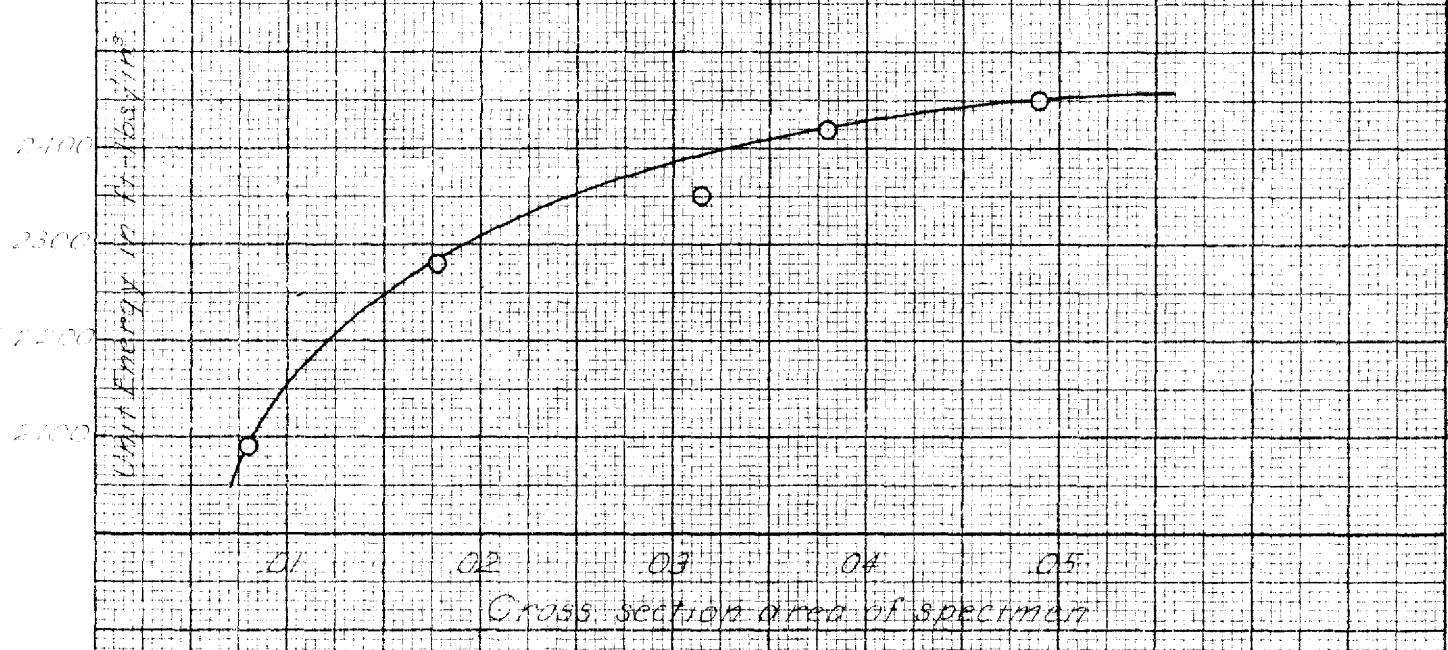

Figure 3

TEST PROCEDURE

Test Specimens

In order to obtain maximum uniformity, the specimens for each material were cut from the same billet. Photomicrographs were made of each material in three mutually perpendicular planes as a means of defining the grain structure.

Tests in which the longitudinal axis of the specimen is parallel to the grain of the material are designated as "with grain" in the table and accompanying discussion. Those in which the longitudinal axis of the specimen is perpendicular to the grain direction are designated as "cross grain."

Tests conducted by personnel of the Douglas Aircraft Company.

Tension

The tension specimens (Figure 4) were tested in a Baldwin-Southward 40,000 lb. capacity machine. The ends of the specimens were attached to spherical-ended fittings used in the testing machine for tension tests. In order to be certain that there was no bending in the test, two

Huggenberger type extensometers were attached diametrically opposite and their readings compared. The average strain readings of the extensometers were used as the strain of the specimens and these values were plotted against stress to obtain a stress-strain diagram. From these diagrams the modulus of elasticity was computed.

Shear

The shear specimens (Figure 4) were made to fit a standard rivet shear block. This method of testing places the specimen in double shear and the character of the failure indicated that there was no bending in the test. The tests were conducted with the Baldwin-Southwark machine.

Compression

The compression specimens (Figure 4) were tested in the Baldwin-Southwark machine. They were placed between spherical ends to eliminate bending. Readings of the diameters were periodically taken with a micrometer and these plotted against stress were used in conjunction with the modulus of elasticity determined in the tension tests to compute the Poisson's ratio.

Tests conducted at the California Institute of Technology.

Fatigue

These tests were conducted on a machine in the structures laboratory of the California Institute of Technology which is essentially a rotating cantilever beam type. The specimen (Figure 4) is mounted with one end in the tapered hole of a ball bearing that is connected by means of spiral bevel gears to a shaft which in turn is directly connected to an electric motor. The other end of the specimen fits into a similar ball bearing with a tapered hole. This latter bearing has a long arm attached to it upon which weights are suspended. The moment produced by these weights acting at the end of the arm produces bending in the specimen, and with rotation, the stress is alternated from a positive (tension) maximum to a negative (compression) maximum during each revolution. The speed of rotation was constant at approximately 3000 r.p.m. The cantilever loading of the specimen introduces direct compressive stresses but of such magnitude as to be considered negligible, as in no test did the ratio of direct compressive stress to maximum bending stress exceed 0.002.

Maximum stress in the specimen was computed in accordance with the formula for a simple beam in bending.

$$\sigma = \frac{My}{I}$$

where: σ maximum stress
M applied bending moment
y radius of specimen at the test section
I moment of inertia of the test section

The fatigue strength of the material was defined at 10,000,000 cycles, i.e., 20,000,000 reversals of stress. This limit is considered to cover the fatigue conditions encountered throughout the comparatively short life of an airplane and is sufficient to determine the effect of grain direction upon fatigue strength.

Izod Impact (notched bar)

The Izod impact specimens (Figure 5) were tested in a standard Tinius-Olsen, 120 ft. lb. capacity, impact machine. The specimen was placed in the machine in such a manner as to insure the hammer hitting each specimen at the same relative place. After the specimen was in place the hammer was raised to its maximum potential energy position (120 ft. lb.) and with the indicating hand in the zero position the hammer was released. The striking velocity of the hammer was 11.35 ft./sec. The energy absorbed in fracturing the specimen was indicated by the hand upon the scale.

Fremont-Izod Impact

These specimens (Figure 5) were tested in the same manner as the standard Izod type. The only variation in the specimens was in the form of the notch at the section of fracture.

Tension Impact

These specimens (Figure 5) were tested in the Tinius-Olsen impact machine in accordance with the technique outlined in the section of this paper dealing with the Tension Impact Test.

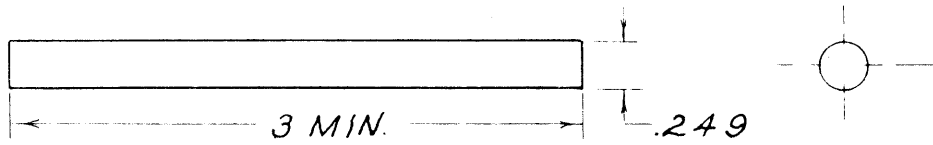

Shear Specimen

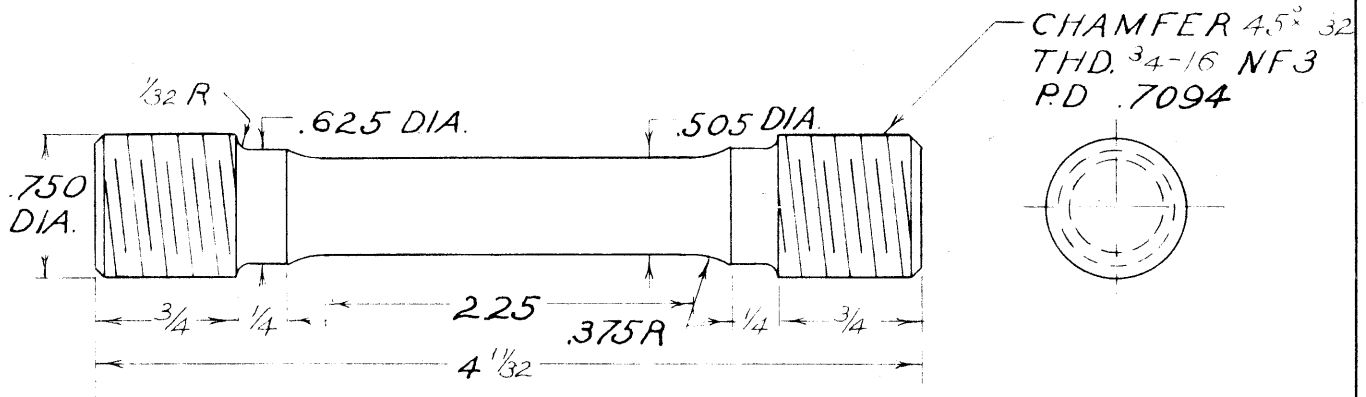

Tension Specimen

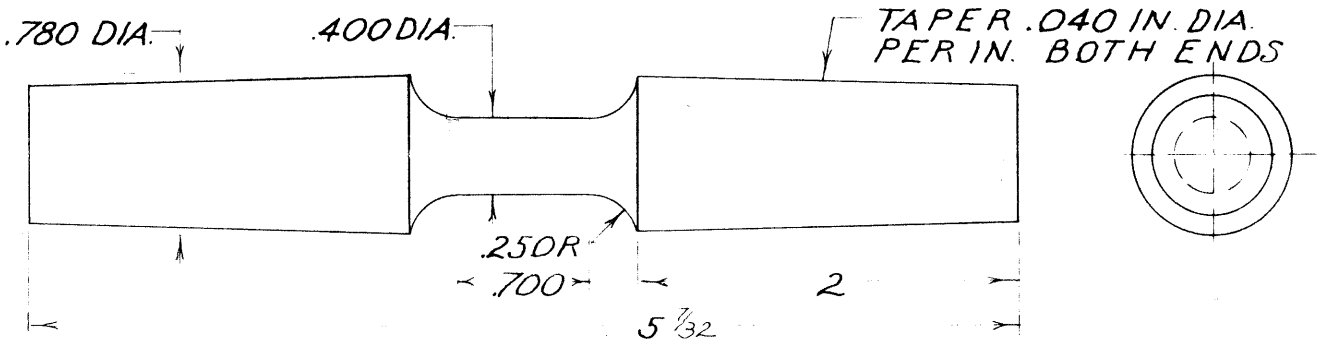

Fatigue Specimen

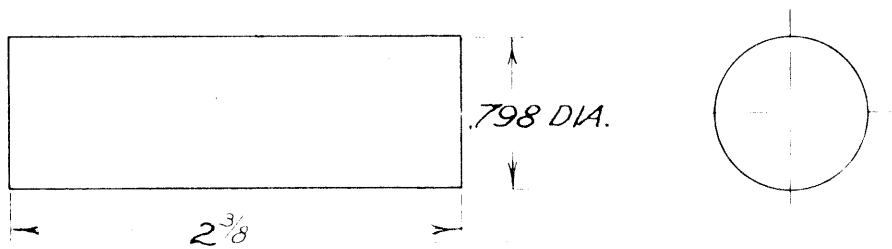

Compression Specimen

Figure 4

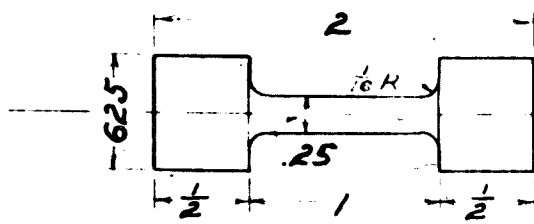

Tension Impact Specimen

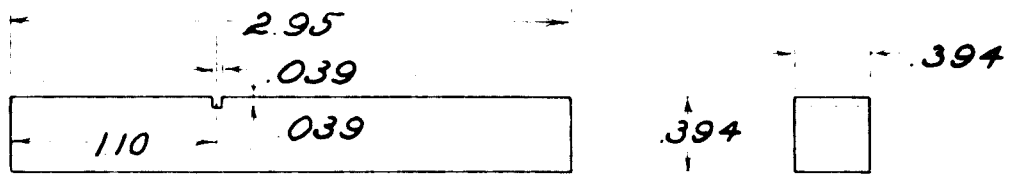

Fremont-Izod Impact Specimen

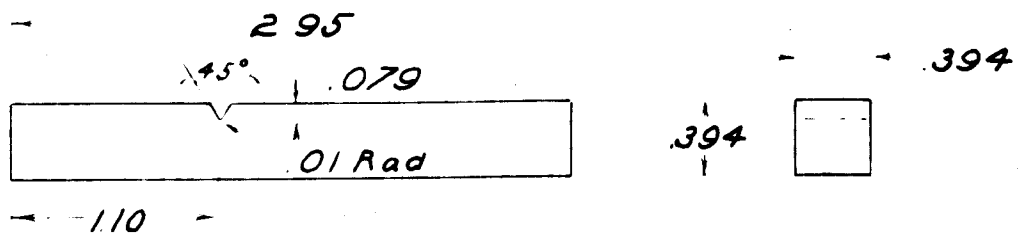

Izod Impact Specimen

Figure 5

ALUMINUM ALLOY 14S-T

The aluminum alloy, 14S-T, is a high strength, heat treatable, forging alloy which is finding increasing favor in the aircraft industry as a material for the manufacture of highly stressed fittings. It is generally furnished to the manufacturer in the form of a hand forged billet approximately 5" x 5" in cross section. The test specimens were cut from a single billet of this type.

The photomicrographs (Figure 6) show the grain size to be comparatively large, due in part to the fact that there has been little breaking down of the original ingot. It is probable that the additional working received in the forging of a fitting would break down the grain structure to a considerably smaller size. For this reason, certain properties, such as fatigue strength and energy absorption, may be somewhat improved in the finished forgings. However, a billet of approximately this size was required in order to obtain homogeneous material for all the physical tests.

Photomicrographs of the test material were taken in three mutually perpendicular planes (Figure 6). These planes are given color designations, as indicated in the sketch, for the purpose of ready identification.

In the photographs of typical fractured specimens (Figure 7) the extremely fibrous appearance of the cross grain breaks is in decided contrast to the velvety look of the with grain fractures.

The test results are presented in both tabular and graphical form (Figures 8 and 9).

A comparison of impact values clearly indicates the serious deficiencies in energy absorption for the cross grain specimens.

The strength comparisons show that quoted values are conservative in all cases. The large variation in fatigue strength with grain direction should be noted.

The deformation comparison chart presents the effect of grain direction upon the amount of plastic deformation which occurs before failure, and also shows that deformation under static and dynamic loadings are in good agreement. This last fact tends to uphold the theory that the process of deformation and rupture is identical in the two cases. Another point to be noted is that the cross grain elongation as indicated by static test is considerably less than the quoted value.

Summary

The tests indicate that the quoted values of physical properties of 14S-T can be readily obtained except for static elongation in the cross grain direction. No impact values are quoted in available literature, but the serious reduction of energy absorption in cross grain specimens reveals a quality of this alloy which should not be overlooked. This characteristic of the material emphasizes the need for extremely careful forging design if maximum structural efficiency is to be attained. The necessity for keeping grain direction parallel to principal stresses and for avoiding sharp re-entrant angles is quite apparent. It is believed that this material should be used with caution if fatigue or impact conditions are to be encountered or if the forging is very complicated and a reasonable stress analysis cannot be made.

ALUMINUM ALLOY 24S-T

This aluminum alloy is in common use in the aircraft industry in the form of sheet, bar, extrusions, and tubing. A piece of 3/4" x 6" rectangular bar stock was used for making a complete set of test specimens. In addition, a number of static test specimens were made from a piece of 1/4" plate for the purpose of determining the effect of grain size on certain physical properties.

The photomicrographs (Figure 11) show the relative grain sizes and assign color designations to the three mutually perpendicular planes.

An inspection of photographs of the fractured test specimens (Figure 12) reveals the marked difference in appearance of the with and cross grain breaks.

The complete test results are presented in tabular and graphical form (Figures 13 and 14).

A comparison of tension impact values shows that this material maintains its energy absorption ability to a high degree in the cross grain direction.

Attention is called to the graph of the notch sensitivity tests (Figure 14). It is to be noted that the values obtained vary not only with the grain direction in the specimen but also with the plane in which the notch is machined.

Strength comparisons indicate that quoted values were obtained in all tests. Reduction of grain size improves both the yield point and the ultimate strength of the alloy.

Elongation and reduction of area obtained from the static and dynamic tension tests are in fair agreement and again tend to uphold the theory that the processes of rupture in the two cases are identical. It should be noted that quoted elongations were obtainable in the cross grain direction.

Summary

The tests indicate that all quoted values of the physical properties of 24S-T are readily obtainable. No impact values are quoted but the data show that this material is comparatively satisfactory in this respect.

It is believed that the designer may use this material with confidence as test values, irrespective of grain direction, exceeding quoted allowable values.

REFERENCES

1. Mann, H. C.: Relation between Tension Static and Dynamic Tests. A. S. T. M. Proceedings, Vol. 35, Pt. II, 1935.
2. ANC-5, Strength of Aircraft Elements. Army-Navy-Commerce Committee on Aircraft Requirements, January 1938.

ALUMINUM ALLOY 14S-T

Designation Of Three Mutually Perpendicular Planes
With Photomicrographs Of Grain Structure In Each Plane

Magnification - 100 Diameters

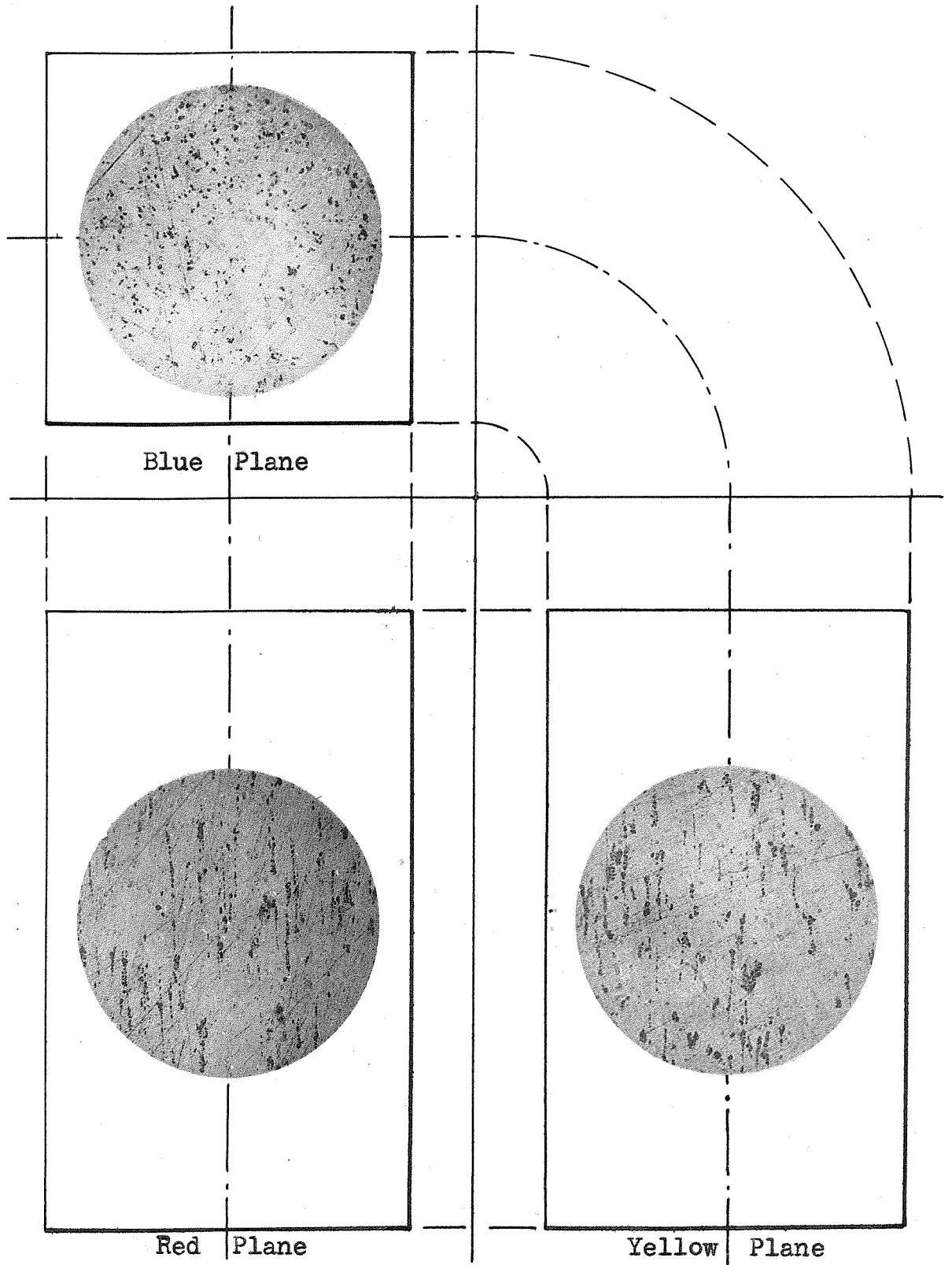
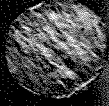

Figure 6

14S-T
SHEAR SPECIMEN
WITH GRAIN



14S-T
SHEAR SPECIMEN
CROSS GRAIN



14S-T
STATIC TENSION SPECIMEN
WITH GRAIN

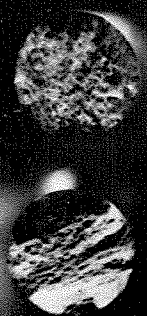

14S-T
STATIC TENSION SPECIMEN
CROSS GRAIN

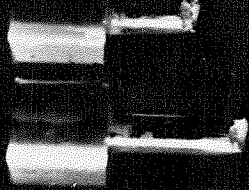

14S-T
IZOD IMPACT SPECIMEN
WITH GRAIN

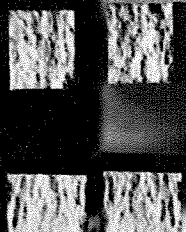

14S-T
IZOD IMPACT SPECIMEN
CROSS GRAIN

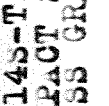

14S-T
FATIGUE SPECIMEN
WITH GRAIN



14S-T
FATIGUE SPECIMEN
CROSS GRAIN

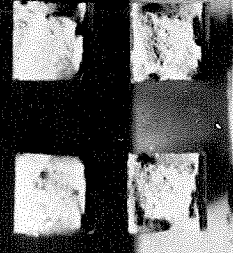

14S-T
FREMONT IMPACT SPECIMEN
WITH GRAIN

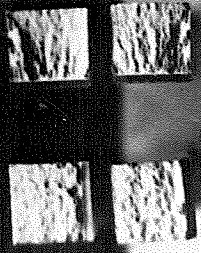

14S-T
FREMONT IMPACT SPECIMEN
CROSS GRAIN

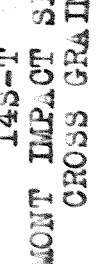

14S-T
TENSION IMPACT SPECIMEN
WITH GRAIN

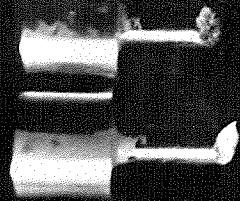

14S-T
TENSION IMPACT SPECIMEN
CROSS GRAIN

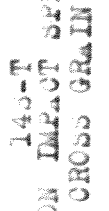

Figure 7.

ALUMINUM ALLOY 14S-T

Tabulated Results Of Physical Tests

TEST	Specimen Grain Direction	YIELD		ULTIMATE		ELONGATION		REDUCTION OF AREA
		Test	*Quoted Allowable	Test	*Quoted Allowable	Test	*Quoted Allowable	Test
Static Tension	#3 With	60,000	50,000	70,800 1%	65,000	12.3% 19%	10%	24.3% 11%
	#2 Cross	62,500 8%		71,150 3%	65,000	6.9% 2%		6.5% 8%
Shear	#1 With			38,760	39,000			
	#1 Cross			41,060				
Compression	#3 With			74,700 2%	65,000			
Fatigue	With			18,000	12,000			
	Cross			12,000				
Tension Impact	#4	Energy in ft.lbs.					20%	
	With		37.5		15%	12.5%		30.5%
	#5 Cross		20.2		11%	5%		43%
Izod	#5 With		5.6		10%			
	#5 Cross		1.9		21%			
Izod Fremont	#5 With		11.1		13%			
	#5 Cross		3.3		24%			

x%

Indicates maximum variation in per cent from mean value.

#

Indicates number of specimens tested.

*

STRENGTH OF AIRCRAFT ELEMENTS, Army-Navy-Commerce Committee On Aircraft Requirements.

Figure 8

ALUMINUM ALLOY 14S-T

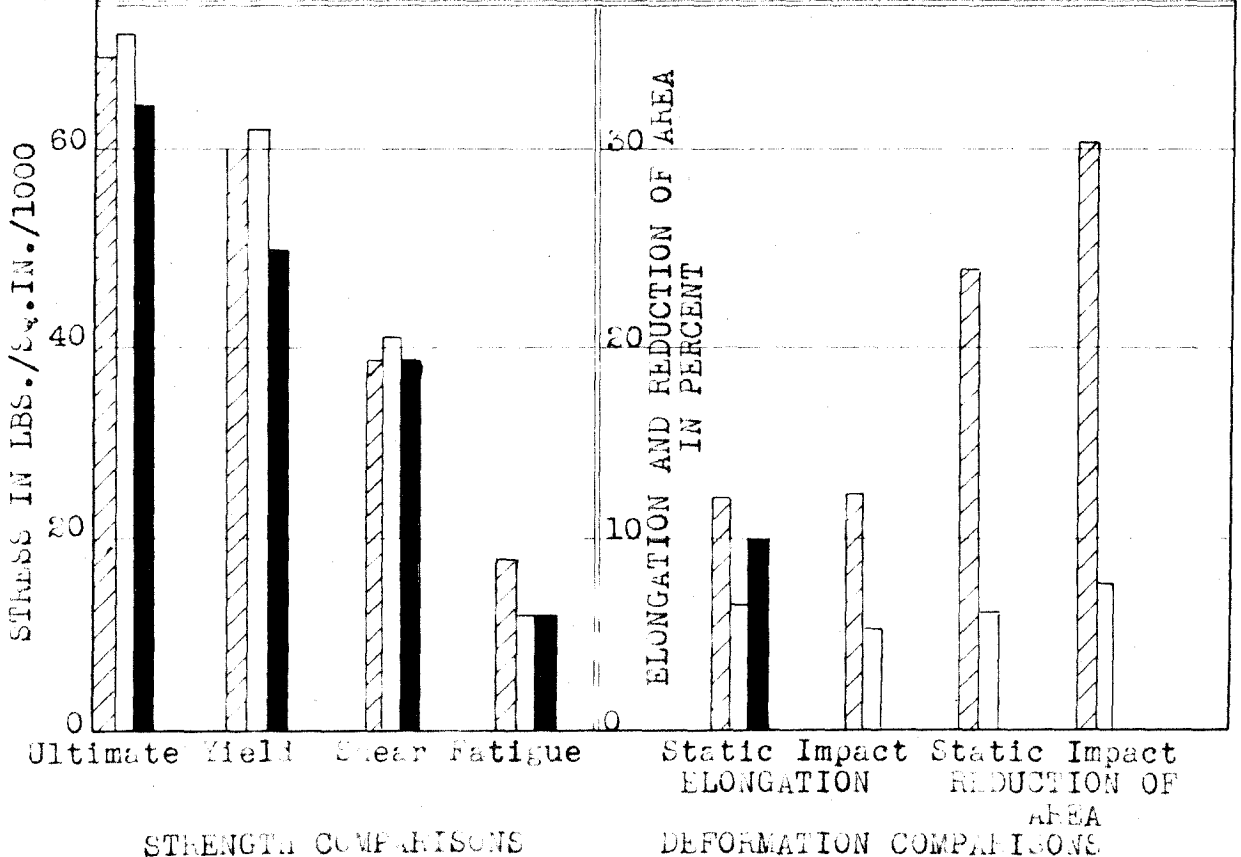
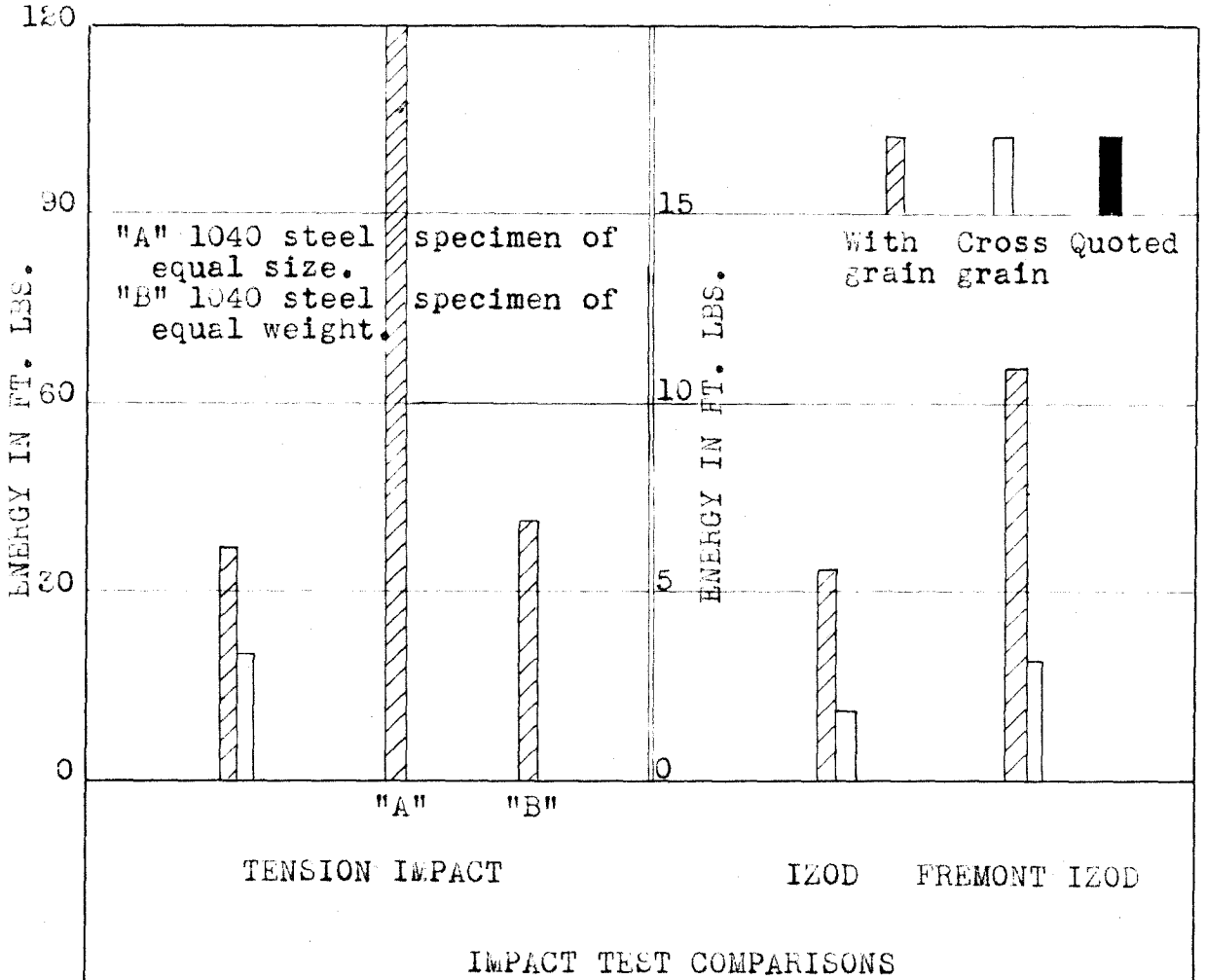

Figure 9

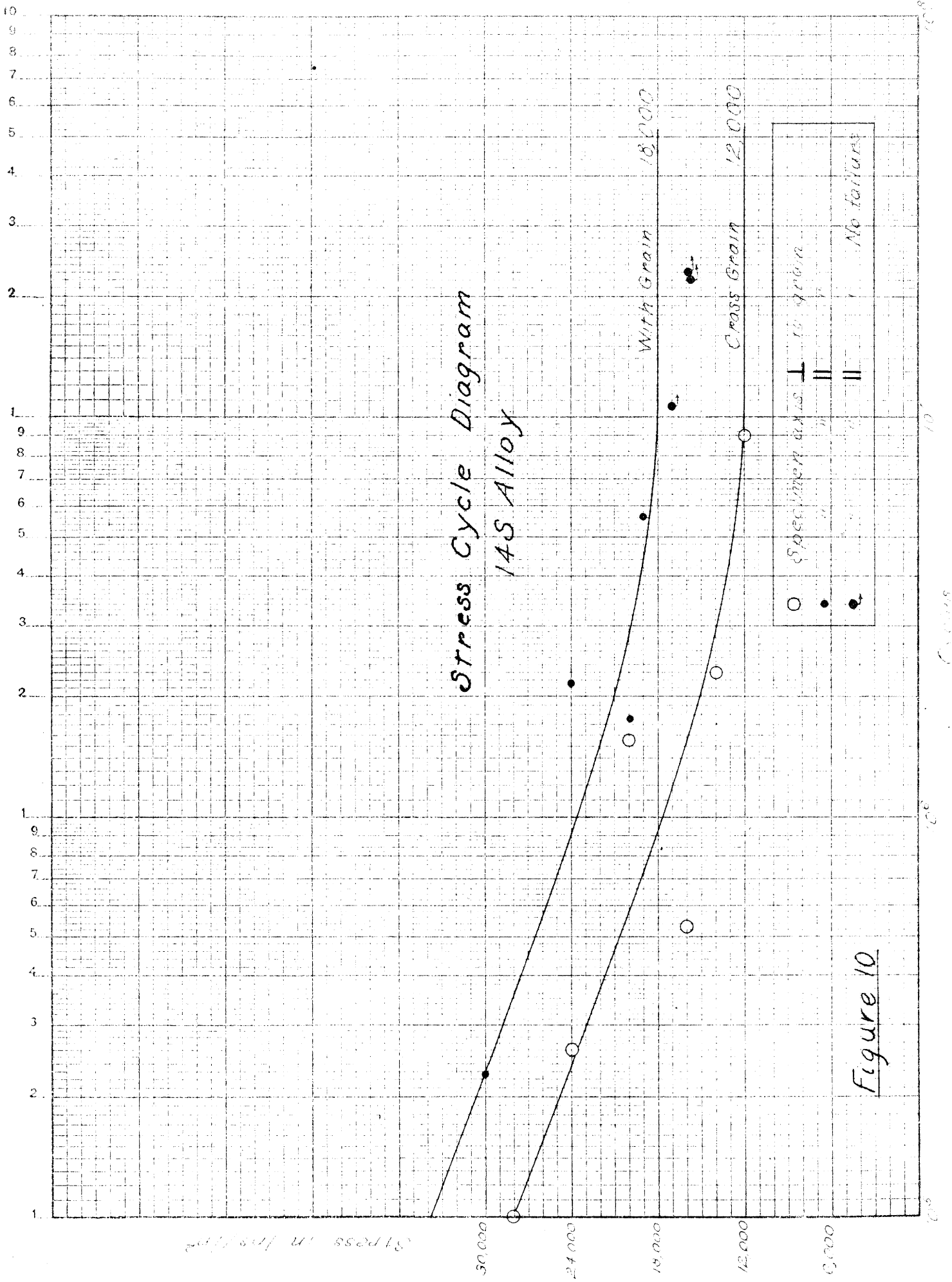
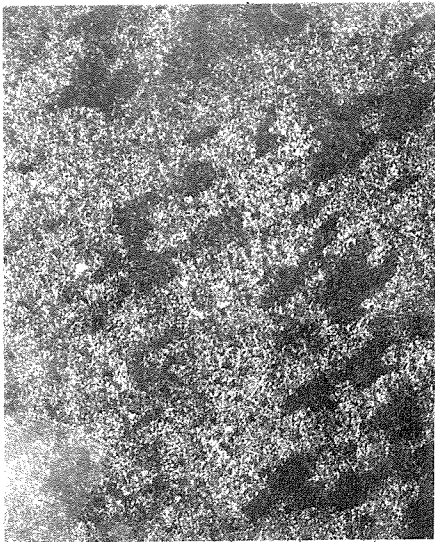

Figure 10

ALUMINUM ALLOY 24S-T

Designation Of Three
Mutually Perpendicular Planes
With Photomicrographs Of Grain
Structure In Each Plane

Magnification - 50 Diameters



Blue Plane
Large Grain

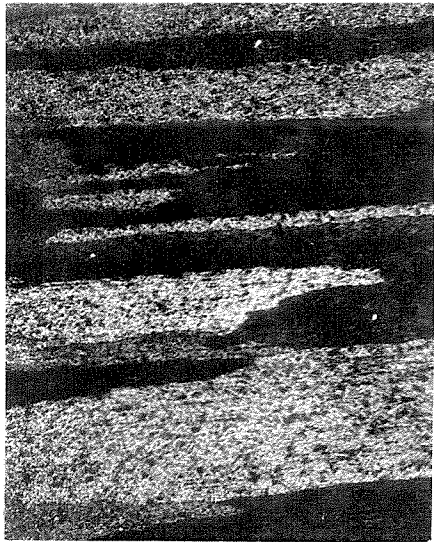

Red Plane
Large Grain



Yellow Plane
Large Grain

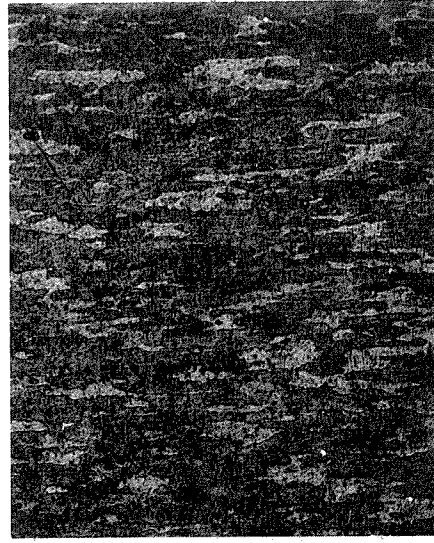

Yellow Plane
Small Grain

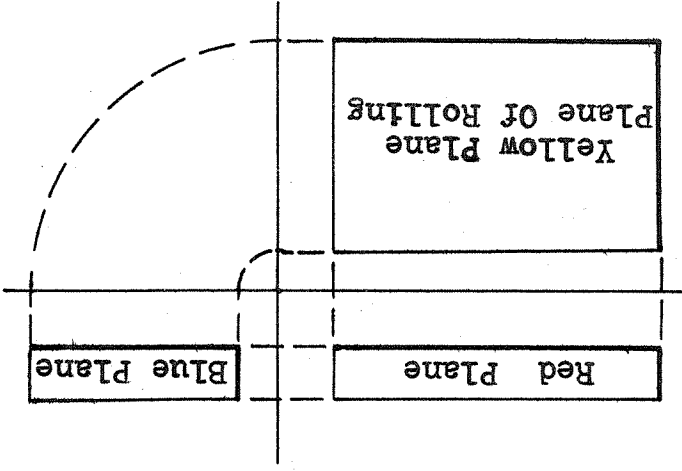



24S-T
FATIGUE
WITH GRAIN



24S-T
FATIGUE
CROSS GRAIN

24S-T
STATIC TENSION
WITH GRAIN
1/4" Plate



24S-T
STATIC TENSION
CROSS GRAIN
1/4" Plate

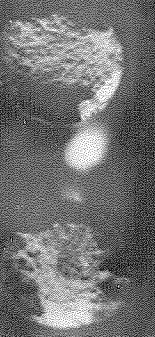

24S-T
STATIC TENSION
WITH GRAIN



24S-T
STATIC TENSION
CROSS GRAIN

24S-T
FREMONT IMPACT
CROSS GRAIN

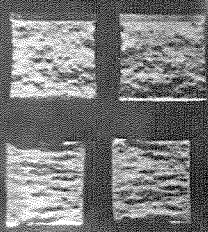

24S-T
IZOD IMPACT
CROSS GRAIN

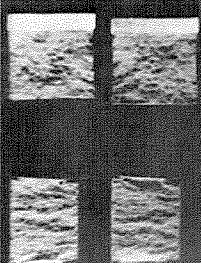

24S-T
FREMONT IMPACT
WITH GRAIN

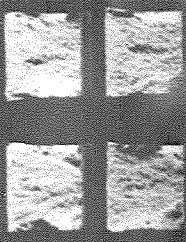

24S-T
IZOD IMPACT
WITH GRAIN

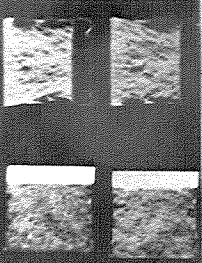

24S-T
TENSION IMPACT
WITH GRAIN

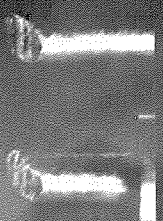

24S-T
TENSION IMPACT
CROSS GRAIN

ALUMINUM ALLOY 24S-T

TEST	Specimen Grain Size & Direction	YIELD		ULTIMATE		ELONGATION		REDUCTION OF AREA	
		Test	*Quoted Allowable	Test	*Quoted Allowable	Test	*Quoted Allowable	Test	
Static Tension	Large	#3 With	2% 39,700	40,000	1% 65,000	62,000	5% 21.6%	14%	4% 21.3%
		#1 Cross	40,000		63,900		14.5%		13.0%
	Small	#3 With	1% 50,500	40,000	1% 69,150	62,000	7% 21.4%	15%	3% 25.7%
		#1 Cross	45,200		68,200		22.5%		23.5%
Shear	Large	#6 With			3% 42,400	37,000			
	Small	#6 With			5% 43,060	37,000			
Compression	Large	#3 With			Over 78,000	62,000			
	Small	#4 With			Over 78,000	62,000			
Fatigue	Large	With			18,700	14,000			
		Cross			18,000				
Tension Impact	Large	Energy in ft.lbs.							
		#5 With					8% 51.2	14% 18.4%	15% 22.6%
		#5 Cross					9% 39.4	5% 15.3%	25% 15.2%
Izod	Large		Plane Of Notch		Energy (ft.lbs.)		Plane Of Notch		Energy (ft.lbs.)
		With	#5 Yellow		9.7	3% 9.7	#4 Red		8.4
		Cross	#5 Blue		4.8	14% 4.8	#2 Yellow		6.5
Fremont Izod	Large	With	#9 Yellow		15.8	11% 15.8	#7 Red		13.6
		Cross	#3 Blue		10.0	1% 10.0	#3 Yellow		11.8

xx% Indicates maximum variation in per cent from mean value.
 # Indicates number of specimens tested.
 * STRENGTH OF AIRCRAFT ELEMENTS, Army-Navy-Commerce Committee on Aircraft Requirements January 1938

Figure 13

ALUMINUM ALLOY 24S-T

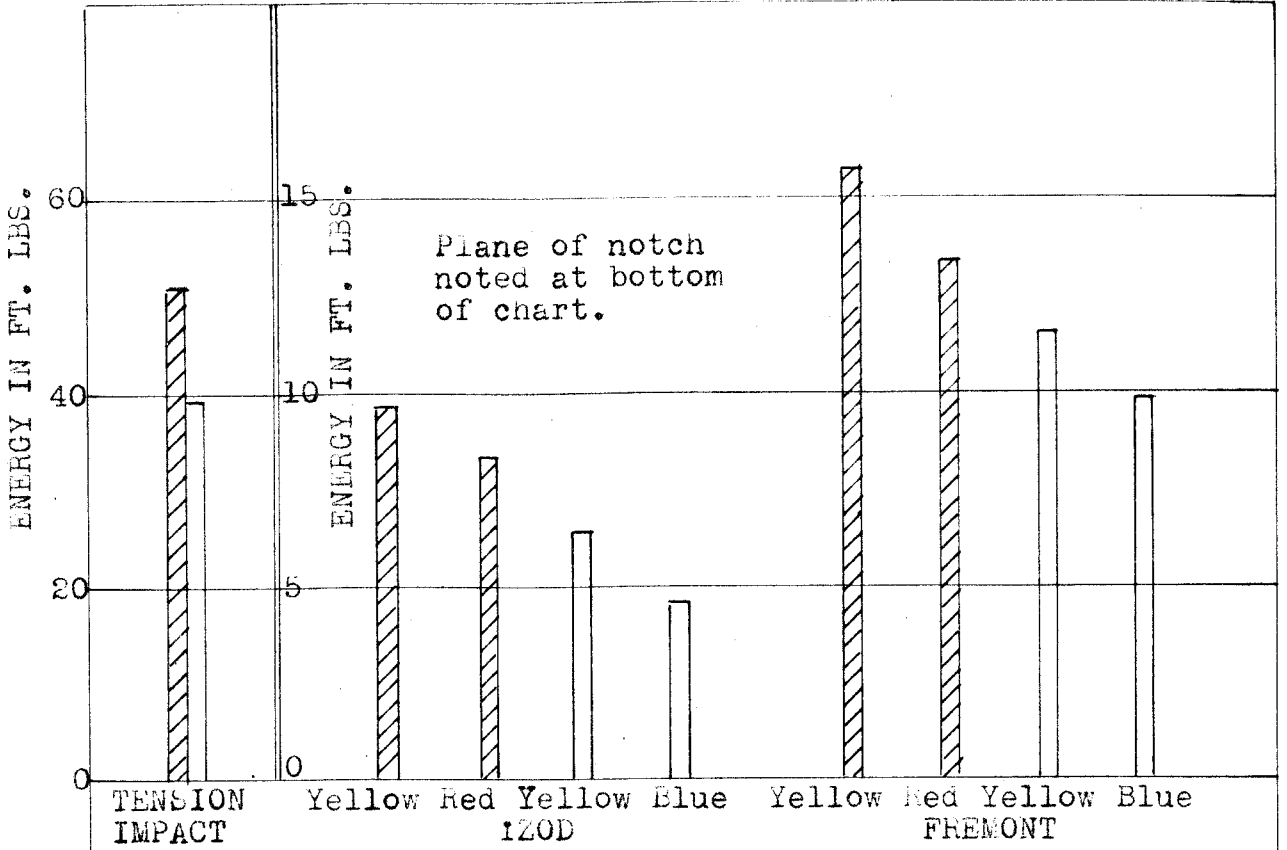

IMPACT TEST COMPARISONS

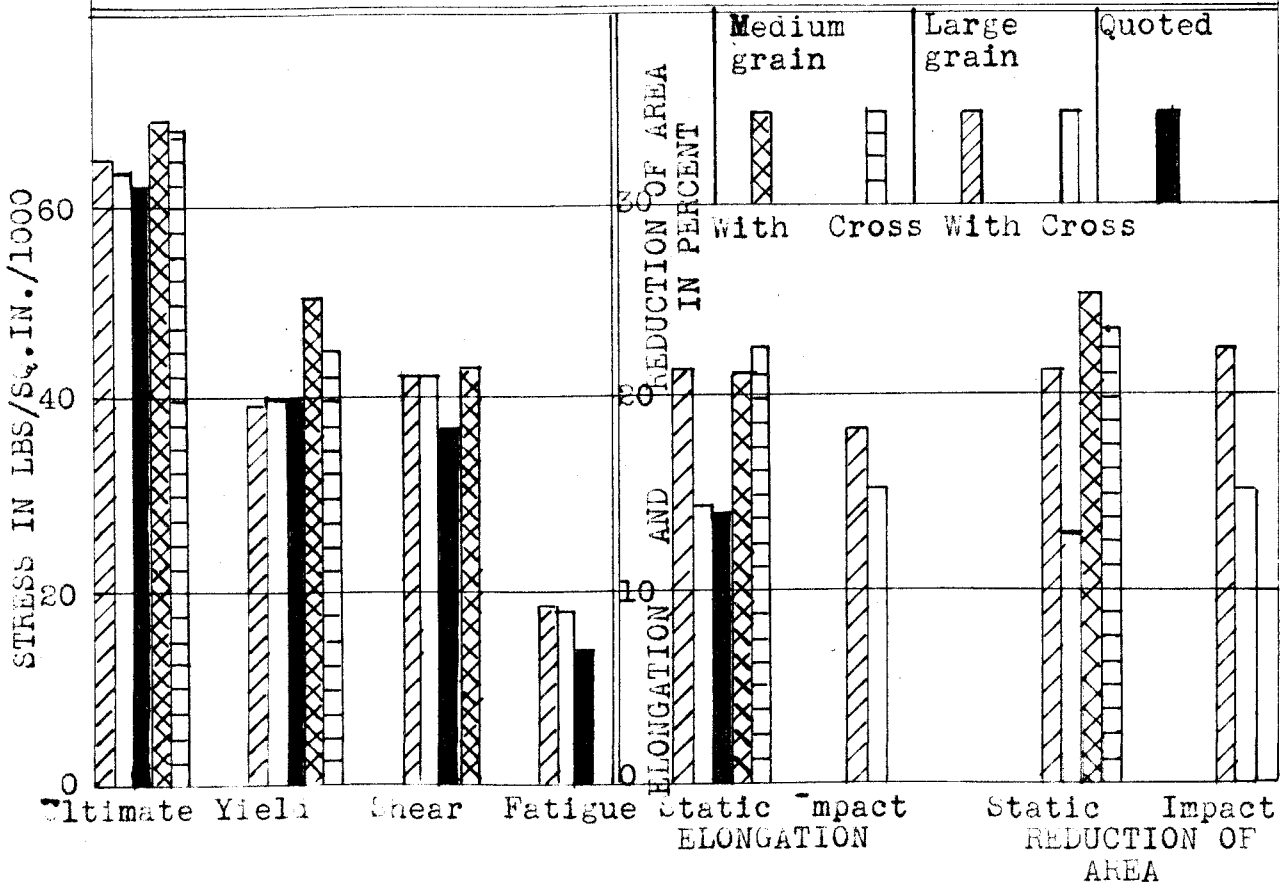

STRENGTH COMPARISONS

DEFORMATION COMPARISONS

Figure 14

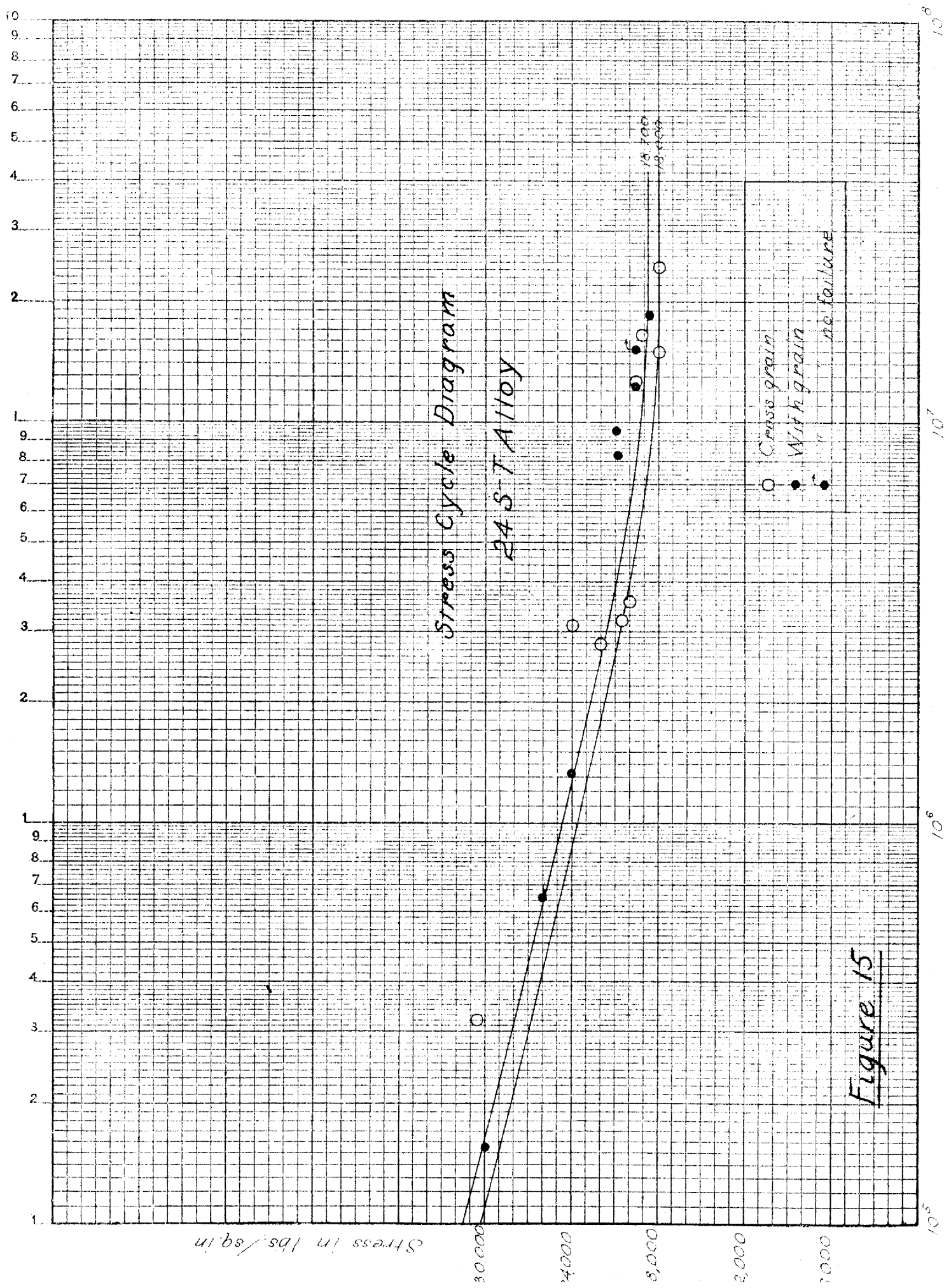

Figure 15