

HIGH AIR-EFFICIENCY
INSULATION

THESIS

BY

F. W. MAXSTADT

In Partial Fulfillment of the Requirements
for the

Degree of
DOCTOR OF PHILOSOPHY

California Institute of Technology

1931

ABSTRACT

The subject is introduced by a review of some of the work of others which seems not to be generally known. Its beginning is traced to the application of three well known principles of electrostatics¹ which are presented in detail. Examples of the limitations of elementary electrostatic theory are set forth.

Taken in the order of their influence, each of ten or more factors which control the arc-over strength of solid insulators in air are analyzed, with experimental data accompanying each analysis.

A new means of increasing the arc-over strength of an insulator is suggested and experimental results for a few samples are presented.

Time did not permit extending the investigation to the arc-over strength of insulators under oil, but many of the factors herein analyzed for insulators in air apply almost directly to oil.

A mechanism of arc-over of solids in air is suggested although a great deal more data will be necessary to justify it.

1. Namely the behavior of dielectrics of different specific inductive capacity when used in series, in parallel, and in some intermediate arrangement.

INTRODUCTION

Late in 1906, the highest commercial transmission voltage (effective value, line to line) leaped from 70 kv. to 120 kv., a daring adventure on the part of engineers and their backers. It was made possible by the development of the Hewlett¹ "suspension" insulator for overhead transmission lines.

The next big step in the improvement of insulation came as a result of the pressure put upon designers of indoor high voltage apparatus to produce terminal bushings (then the weakest link in the chain) of rating comparable with transmission line insulation. These terminal bushings are the insulators through which conductors enter the iron tanks of transformers and switches or enter the roofs of buildings.

Fortescue² by applying Maxwell's³ potential functions to the calculation of electric flux distribution, and using a good deal of judgement based on correct electrostatic principles, designed a transformer terminal bushing which withstood upwards of half a million volts effective value. He and Farnsworth also constructed and

1. E. M. Hewlett, Trans. AIEE 26 (2) 1259, (1907).
2. C. L. Fortescue & S. W. Farnsworth, Trans. AIEE 32(1) 893 (1913) also C. L. Fortescue Trans. AIEE 32 (1)907(1913).
3. James Clerk Maxwell "A Treatise on Electricity & Magnetism" Oxford.

tested a small bushing of the rod-and-ring electrode type, Fig. 4, which to their surprise, arced over at less than half the puncture strength of air¹ alone. They had, however, achieved very great success, for even the arc-over strength which proved a disappointment to them, was five times as good as that of the best bushings then in use.

Chester W. Rice, in a monumental paper², four years later, showed how to accurately calculate by means of Maxwell's equations the flux distribution maps for many different electrode shapes. He also showed details of a perfected salt tank method for experimentally determining flux maps of electrodes whose contour did not readily lend itself to mathematical treatment. In addition to determining the correct shape of the insulation surface from purely theoretical considerations, Rice carried out a large number of tests on experimental bushings built according to theory, always with the result, however, as obtained by Fortescue and Farnsworth, that their arc-over strength was less than half the puncture strength of air alone.

Rice called it a "surface effect" which he attempted to test more thoroughly by placing right circular cylinders of various insulating materials in the homogeneous field between two parallel flat electrodes.

1. About 20 kv. effective per centimeter.
2. C. W. Rice, Trans. AIEE 36, 905 (1917).

It was not until Schwaiger¹ of Karlsruhe described his arc-over tests on porcelain that the important humidity factor affecting this surface phenomenon was presented. The relative humidity of the surrounding atmosphere determines to a larger extent than any other factor excepting atmospheric pressure, the arc-over strength of a given surface.

In 1926-27, George K. S. Damos and Wm. A. Lewis² began work on circular cylinders of soft glass, hard rubber, porcelain, and Bakelite at California Institute of Technology, testing the arc-over voltage in terms of atmospheric humidity and also the time required for the sample to come to equilibrium with the surrounding atmosphere after it had been dried in an oven for several hours at 90° c.

The following year, J. W. Thatcher³ continued the tests on similar materials in constant humidity atmospheres and at temperatures from 40°C to 60°C adding Pyrex to the list of substances tested.

The present work was begun in the fall of 1928 and has been carried on with the assistance of E.E.Kinney⁴,

1. A. Schwaiger, E.T.Z. 26 875 (June 29, 1922).
2. George K.S.Damos & W.A.Lewis, Master's Thesis 1927 on file in the Main Library, Calif. Institute of Tech.
3. J.W.Thatcher, Master's Thesis 1930 on file in Main Library C.I.T.
4. E.E.Kinney, Master's Thesis 1930 on file in Main Library C.I.T.

who was especially concerned with surface resistance measurements, and K. M. Wilson¹ who has studied the effect of changes in atmospheric pressure and the effect of extremely dry atmospheres, below one per cent relative humidity. Tests have been carried out on the arc-over voltages of right circular cylinders of the material, in homogenous fields between flat parallel plates. A few experiments were conducted on slender fibres of Pyrex and of Quartz, also on strips of paper, cloth and Cellophane and one series of readings on a stack of squares of paper. All of the arrangements were in homogenous fields parallel to the surface of the specimen.

1. K.M.Wilson, Report 1931 bound as appendix with this thesis.

ELEMENTARY ELECTROSTATIC THEORY

FARADOID PRINCIPLE

If two different dielectrics are placed between flat electrodes A and B, Fig. 1, the respective thicknesses of these dielectrics being d_1 and d_2 the total voltage V between the electrodes will be shared by the dielectrics as follows:

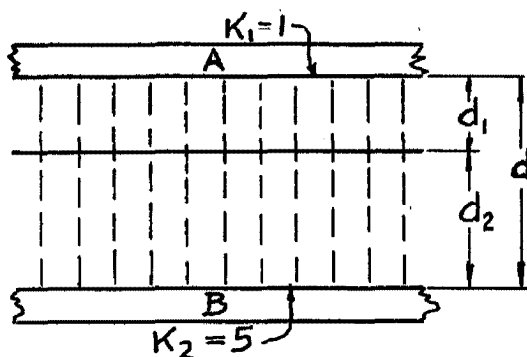

DIELECTRICS IN SERIES
Fig. 1

$$V_1 = \frac{K_2 d_1}{K_1 d_2 + K_2 d_1} V$$

$$V_2 = \frac{K_1 d_2}{K_1 d_2 + K_2 d_1} V$$

$$E_1 = \frac{V_1}{d_1} = \frac{K_2}{K_1 d_2 + K_2 d_1} V$$

$$E_1 K_1 = E_2 K_2$$

Since the denominators of the V_1 and V_2 equations are the same, it is obvious that the dielectric of lower permittivity (specific inductive capacity) perhaps air, will be subjected to the greater stress. Assume, for example, two electrodes 1 cm. apart, having impressed between them 15 kv. effective¹. If air alone fills the gap, the stress on the air is 15 kv. per cm. Next, place 0.8 cm. plate of glass $K = 5$. in the gap, leaving 0.2 cm. of air. Letting E_1 represent the stress (voltage gradient) on the

1. Effective values will be used throughout this presentation. They correspond to the kind of values ordinarily indicated by voltmeters and are therefore considered more logical than crest values.

air, $\epsilon_1 = \frac{5}{1 \times .8 \times 5 \times .2} \times 15 = 41.7$ kv/cm. which is considerably above the puncture strength of air (Footnote p. 3).

A second arrangement of two different dielectrics, Fig. 2, shows how they may be placed in parallel and subjected to equal puncture stress no matter what their permittivities. Note that the electric flux lines are always

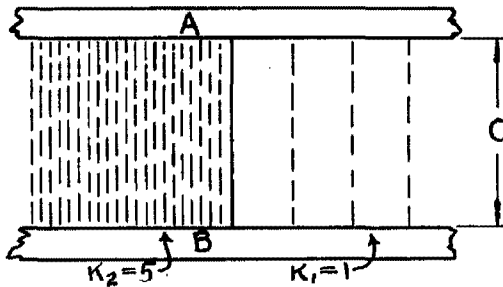

$$\epsilon_1 = \epsilon_2 = \frac{V}{d}$$

DIELECTRICS IN PARALLEL
Fig. 2

parallel to the boundary between the two dielectrics.

In the usually most convenient arrangement, however, the electric flux lines are not parallel to the boundary but meet it at an angle, Fig. 3. The boundary surface is a b.

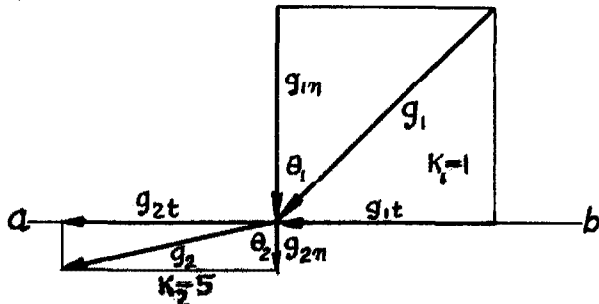

$$K_1 \tan \theta_2 = K_2 \tan \theta_1$$

$$\frac{\epsilon_1}{\epsilon_2} = \frac{K_2 \cos \theta_2}{K_1 \cos \theta_1}$$

FLUX REFRACTION
Fig. 3

A brief analysis of the theory is as follows:
The tangential components of the stress ϵ_{1t} and ϵ_{2t} , one in and the other outside the solid material, are equal, as

in the simple case, Fig. 2. They cannot be otherwise, for there is no discontinuity in that direction. The normal components of the stress g_{1n} and g_{2n} , on the other hand, have the ratio K_2 to K_1 as in Fig. 1 because of passing across a boundary between two different materials. Combining the vectors, resultants g_1 and g_2 which, obviously, are not continuous, are obtained and g_2 suffers a refraction, bending away from the normal. Vectors g_1 and g_2 represent, in direction the path of the electric flux lines and, in magnitude the voltage gradient in each dielectric.

It will be evident upon examination of the vectors that Figs. 1 and 2 are the limiting cases, Fig. 2 being the desirable one in which the gradient is independent of the presence of the solid dielectric. The above reasoning lead Fortescue¹ to the enormous improvement of five to one over his contemporaries in the use of solid insulation in combination with air. The principle just outlined in which the solid insulator is made to conform in shape to the flux lines so there will be no refraction, is known as the Faradoid Principle and insulators so designed are called Faradoid insulators.

DISRUPTIVE STRENGTH OF AIR IN CONTACT
WITH A SOLID DIELECTRIC—SURFACE EFFECT

Fortescue's failure to attain perfection will

1. Loc cit. (1913)

be appreciated when one recalls that his rod-and-ring bushing, Fig. 4, made of shellac and other gums with whiting filler, arced over at 9.1 kv. effective per cm. instead of at the desired value, the disruptive strength of air, 20 kv. per cm.

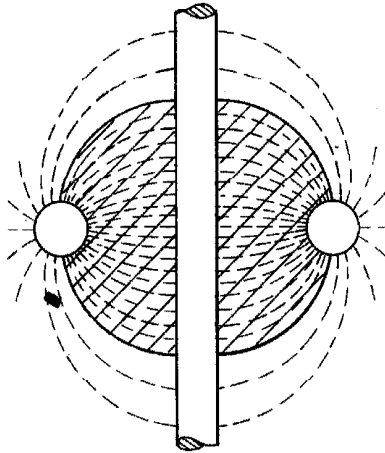

ROD-AND-RING BUSHING
Fig. 4

of them was a copy of Fortescue's theoretical form, Fig. 4,

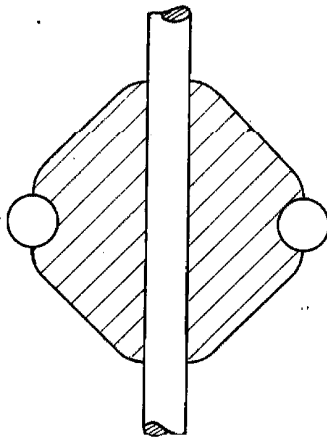

WEED MODIFICATION
Fig. 5

An even more disquieting experimental result has been presented by Weed¹ who was experimenting with insulator bushings about the same time. Weed built several bushings by turning hard rubber in the lathe. One

and another was somewhat similar but with two zones flattened off, Fig. 5. The first arced over at 52.5 kv. effective, the second at 62.5 kv. effective, or a 20 per cent improvement.

The arc-over gradient in the second case was about 19 kv. per cm. which is very close to the ideal. Note

1. J.Murray Weed, Discussion. Trans AIEE 32(1)p.940 1913.

that the better bushing does not conform to the theoretical contour, whereas the other one does.

Rice¹, with another theoretically designed bushing of glazed porcelain, obtained an arc-over strength of 7.1 kv. effective per cm. scarcely more than one third of the ideal value. Seeing that some experiments of a more fundamental nature should be made, he proceeded to test a great variety of insulating materials in the form of right circular cylinders in homogenous fields parallel to the insulation surface, an arrangement electrostatically identical with Fig. 2. At best, only about 85 per cent of the ideal arc-over strength was obtained. Rice advanced two explanations. The first was imperfect contact between electrode and specimen, causing premature corona formation and consequent early arc-over. The second was contamination of the insulator surface by moisture from the atmosphere.

Schwaiger² made extensive tests on porcelain and found a definite relation between relative humidity of the air and the arc-over strength of the insulator. One of his curves, Fig. 6, will illustrate the point.

He further found that certain kinds of inhomogeneity of the electric field resulted in greater arc-over strength of the specimen. Lastly, he showed the effect of

1. Loc. cit. (1917).

2. Loc cit. (1922) also A. Schwaiger, Elektrische Festigkeitslehre, 2nd Ed. 1925 Springer p. 164-173.

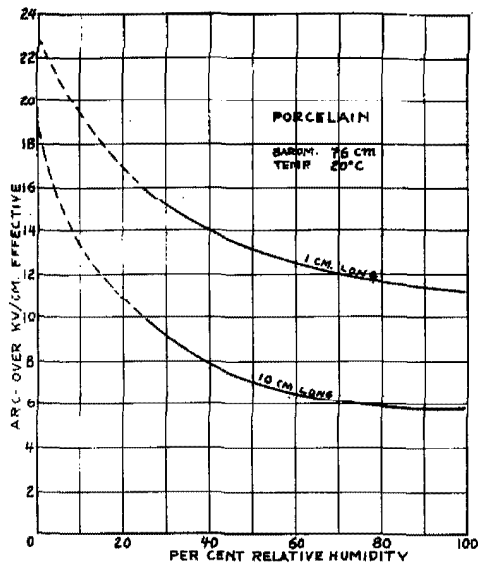

ARC-OVER STRENGTH
Fig. 6 (Schwaiger)

the length of sample and pointed out a rather close analogy between the arc-over characteristics of a solid and the disruptive strength of air.

The foregoing experiments have been reviewed at some length because they show that the elementary electrostatic theory is totally inadequate to account for many of the complex factors involved.

It is at this point the work at California Institute begins and no less than ten important factors which influence the disruptive strength of air when in contact with a solid dielectric have been investigated. These will be presented in the order of importance and the approximate extent of their influence estimated in each case.

RELATIVE HUMIDITY OF THE ENVIRONMENT

When an insulator whose entire surface not in contact with the electrodes is placed parallel to the flux lines in a homogenous field, the effect of moisture contained in the surrounding air is to reduce the arc-over

voltage of the insulation to a value below the disruptive strength of the air alone. Why this should be the case has not been proven but an explanation is suggested in the APPENDIX. Figs. 6, 7, 8, 9 and 10 show characteristic curves obtained for five different substances. Many others have been tested but all (with the exceptions of fused quartz fibres and untreated "Bond" paper) show characteristics similar to those shown. The arc-over voltages, at ordinary humidities, for all of the well known insulating materials will be found to be approximately $1/2$ to $1/3$ the values corresponding to the strength of the air alone when homogeneous field conditions exist.

It is possible to obtain the full strength of the air if the insulation is absolutely dry (for example, having been baked for several hours in a vacuum) and is surrounded by air containing no moisture.

To demonstrate this fact about which there was some doubt, Mr. Wilson¹ and I assembled a vacuum system, Fig. 11, consisting of a Pyrex tube, with a mercury-sealed joint at the bottom, into which could be placed two accurately flat and polished copper electrodes 4.5 cm. diam. and a test sample whose maximum dimensions should be 2.6 cm. diameter X 1.0 cm. long, the electrodes being enough larger than the sample to insure a distribution of field parallel

1. Loc. cit.

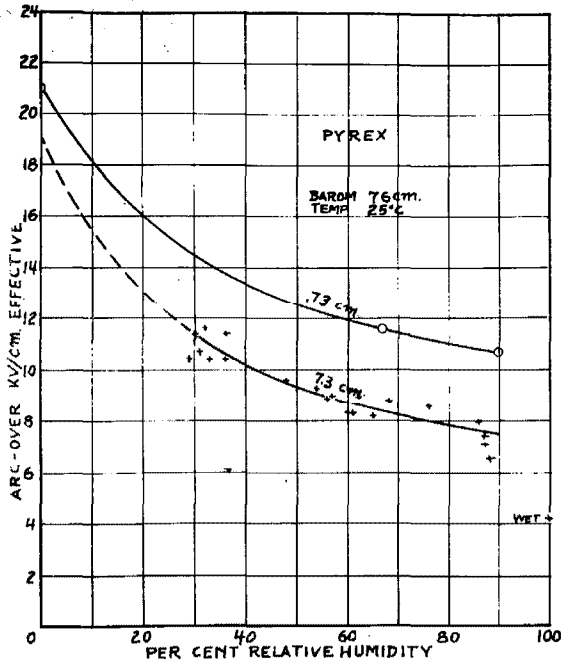

ARC-OVER STRENGTH
Fig. 7

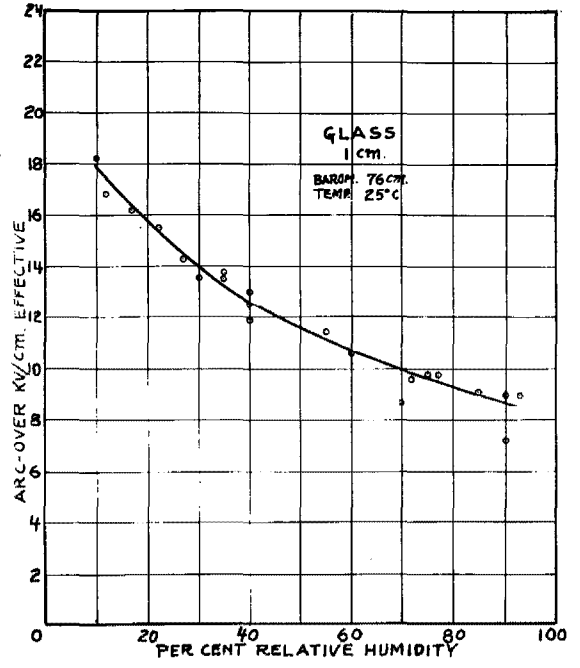

ARC-OVER STRENGTH
Fig. 8

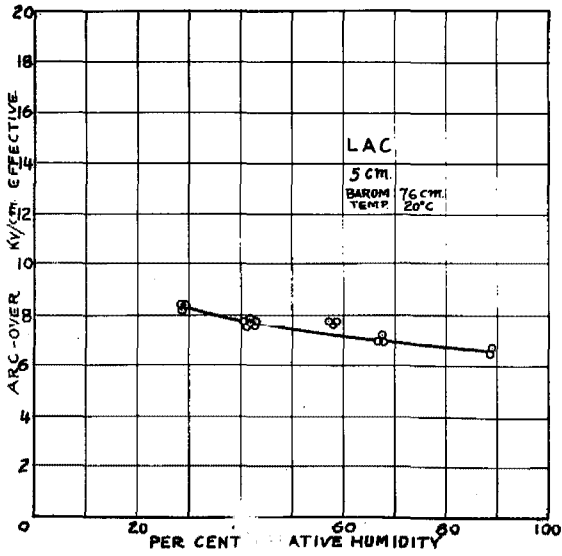

ARC-OVER STRENGTH
Fig. 9
(Schwaiger)

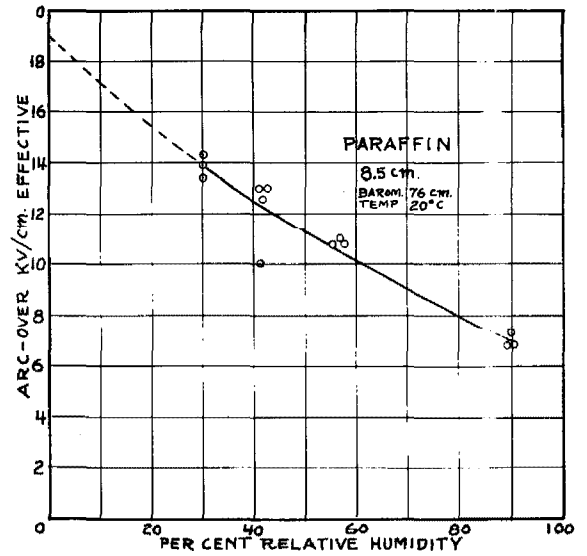

ARC-OVER STRENGTH
Fig. 10
(Schwaiger)

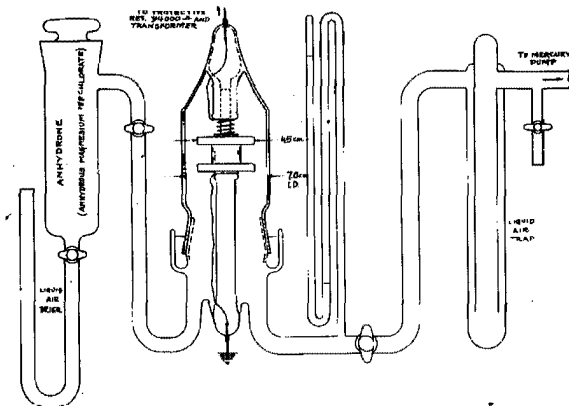

ZERO HUMIDITY APPARATUS
Fig. 11

to its surface. Two different Pyrex cylindrical samples, the ends of which were carefully ground planes although not quite as good as optical flats, were tested. The ends were parallel to better than .001 cm. Chipping of the edges was very slight.

The technique of testing found to give satisfactory results was substantially as follows:

1. The electrodes were buffed on a cloth wheel with ordinary polishing rouge, then rubbed vigorously upon a paper towel to remove excess rouge and improve the finish.
2. The sample was next washed in cold tap water with Proctor and Gamble "Lava" soap and rubbed vigorously with a paper towel.
3. Not more than twenty minutes elapsed between the time of preparing electrodes and sample, and assembling

them in the tube. Care was taken to remove all dust particles from the electrodes and the sample, the latter being handled only with tongs.

4. The rough pump was started and an ordinary vacuum soon obtained, the single stage mercury diffusion pump coming into action in due time.

5. After an hour of evacuating, a furnace was placed over the exhausted tube and the upper part, including electrodes and sample, heated to about 200°C for two hours, care being taken not to heat the mercury-sealed joint.

6. The tube was allowed to cool to room temperature, after which it was again heated to 200°C for two hours. It was then allowed to cool over night and the next day was heated to the same temperature for one hour. The pumps were shut down for the first time since starting, some twenty hours before. While the tube and sample were still warm, air was admitted slowly through a stopcock located in a T-connection between the mercury pump and the liquid air trap. The moisture in the admitted air could thus be extracted by the liquid air trap. Atmospheric pressure was established in the main tube for a moment. Then the pumps were again started and a vacuum reestablished.

7. Tube, electrodes and sample continued to cool in vacuum for an hour or so more, after which air was slowly readmitted, this time through a different inlet. See Fig. 11. The incoming air passed first through a U-tube

immersed in liquid air and second, through a drying tube containing Anhydrous Magnesium Perchlorate, before entering the main tube.

8. As soon as atmospheric pressure was reached (about 20 minutes), voltage was applied to the sample in the regular way described on page 48. Table I gives the results corrected for barometric pressure and temperature as shown by Curves on pages 17 and 20 respectively. This same Table I shows results obtained when immediately after these tests, the electrodes were removed from the special tube, assembled in a Bakelite form (the sample used for an adjusting gage) and tested in open air for puncture of the air alone.

Time	Arc-Over kv./cm. effective	Specimen
11:24 11:38 11:48	*20.6 20.7 20.7	Pyrex 2.6 cm. dia. X 0.73 cm. long Heated in vacuum and cooled several times, for 24 hours. Humidity 0%
12:28 12:29 12:30	20.65 20.7 20.7	Air gap 0.73 between same electrodes with no further polishing. Tested in open air. Humidity 62%

*Protective resistance 94000 ohms.

Table I

W. A. Lewis¹, testing samples of freshly surfaced hard rubber which had been dried for about 24 hours at 90°C in an oven, showed similar results. Sample 1.98 cm. diameter X 7.61 cm. long. Best arc-over voltages 129.5 and

1. Master's Thesis, Damos & Lewis. C.I.T. Library.

130.2. Air gap alone 130.0. Sample 2.54 cm. diameter X 7.59 cm. long. Best arc-over voltage 124.8. Air gap alone 126.0.

It is thus possible, under exceptional conditions, to obtain full disruptive strength of the air even when it is in contact with a parallel solid dielectric.

ATMOSPHERIC PRESSURE

The disruptive strength characteristics of air as affected by pressure have been exhaustively investigated by Peek¹ and others. In order to determine the corresponding nature of the arc-over strength, Mr. Wilson² and I replaced the Pyrex sample in the vacuum apparatus, carefully dried it as before and, starting with a pressure of about 1 cm. of mercury, read arc-over voltages for a large number of pressures up to values slightly above 76 cm. The temperature during the test varied from 22°C to 23°C, a variation small enough to be neglected. A second test was performed, this time on a sample of glass 1 cm. long placed between flat electrodes of large diameter (about 14 cm.). In this test, a bell-jar was used as the vacuum vessel,

1. F. W. Peek, Jr. "Dielectric Phenomena in High Voltage Engineering", Third Ed. 1929, McGraw Hill, p. 129-132.
2. Report bound as appendix with this report,

the vacuum used being that obtainable with the rough pump only and in place of heating to 200°C, a high frequency glow discharge was kept about the sample for two hours. Observations of arc-over voltage starting at atmospheric pressure and decreasing to about 1 cm. of mercury were made.

In Fig. 12,

the circles show the values for .73 cm. length of Pyrex, and the crosses show the values for 1.04 cm. length of glass. The straight line is the generally accepted law of disruptive strength of air. The Y-intercept is taken from Townsend¹ and the ordinate for $\delta = 1$

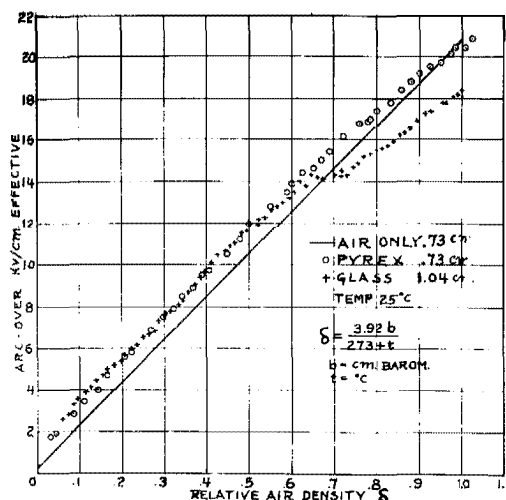

INFLUENCE OF PRESSURE
Fig. 12

from our own data for the air alone, Table I, p. 15. The abscissa are "relative air density", since it was long ago shown by Townsend² that the breakdown strength of a gap between two plane electrodes is proportional to the number of gas molecules in the gap. Relative air density is a measure of the relative number of molecules in the gap.

1. J.S.Townsend "Electricity in Gases" 1915, Oxford.
2. Op. cit.

Referred to standard conditions of 76 cm. pressure and 25°C, relative air density is

$$\delta = \frac{3.92 b}{273 + t}$$

Where b. is cm. of mercury and t is degrees C. In the experiments just described, t was practically constant.

It will be observed that the experimental values in both tests seem to lie on two intersecting straight lines of different slope, the upper slope being smaller. We have no explanation for this.

The pronounced Y-intercept of the lower end of our experimental curve reminds one of the curves for sphere gaps obtained by Peek¹. Each of Peek's spheres of different diameter produces a curve of spark voltage against δ having a Y-intercept which increases when the sphere diameter diminishes. He put it into his formula as a correction depending on the square root of the sphere radius. Physically, it may mean that a certain voltage is always necessary to start the process of ionization on a large scale even for low pressure. Townsend used X-rays or ultra-violet light in all his work and found that the curve passed nearly through the origin, whereas Peek used no ionizing source whatever other than the Cosmic Ray and radioactive sub-

1. Op. cit. page 131, Fig. 106.

stances which are always present. Our tests, like Peek's, have been made without X-rays or other abundant source of ions.

We shall have something to say about the deionizing influence of the solid bodies in a spark gap. See APPENDIX.

At any rate, it is satisfactory in correcting arc-over voltages to standard conditions of 76 cm. pressure and 25°C. to use the divisor δ_1 on the voltage obtained at some other pressure b_1 . That is: a test value, say 17 kv/cm., obtained at 70 cm. pressure can be corrected to 76 cm. pressure by dividing by 0.92. The result is 18.5 kv./cm. The curve does not pass through the origin, so calculation over any considerable range of pressure must be handled with caution.

Temperature effect will be discussed in the next section.

TEMPERATURES

The formula for δ , relative air density, involves the temperature as well as pressure. It was found convenient to use our vacuum apparatus, including the .73 cm. long Pyrex sample, to test the effect of temperature, the pressure remaining constant at 74.2 cm.

Fig. 13 illustrates the effect. The upper group of circles is the test of Pyrex (very dry surface). The

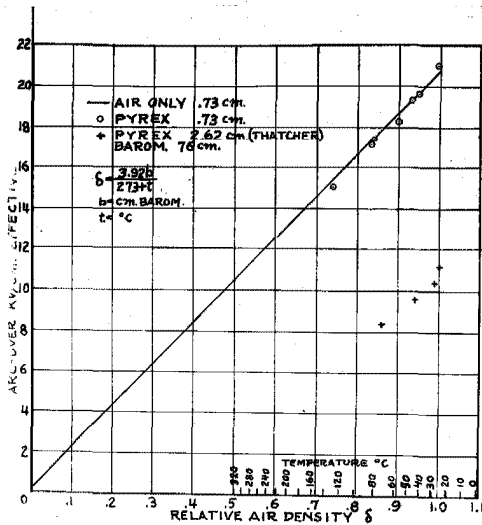

INFLUENCE OF TEMPERATURE
Fig. 13

humidity.

It is difficult to carry the test to values of δ below .75, which represents 123°C, because the sample becomes such a good conductor that Joule heat raises the temperature rapidly when high voltage is applied. One glass sample was almost totally destroyed in the attempt. Error in the reading is also very probable due to voltage drop in the protective resistance that must be used in series with the test set-up in all of this work. Protective resistance used with .73 cm. Pyrex 94000 ohms.

The results as presented in Fig. 13 show no unusual effects and it is evident that the straight line law can be used for temperature correction as well as pressure correction over reasonable ranges.

1. J.W.Thatcher, Master's Thesis, filed in Main Library, C.I.T.

line is a repetition of the curve also used in Fig. 12 representing the accepted law of disruptive strength of air alone in terms of relative air density. The lower group of four points is taken from Mr. Thatcher's¹ data on a 2.62 cm. long Pyrex sample at 61% relative

SIZE & SHAPE -- PLANE ELECTRODES

Just as the disruptive strength of air, or for that matter liquids and solids, depends upon thickness of the layer tested, so does the arc-over strength of a solid insulator depend upon its length. In this section, only the case of uniform field will be considered. The following section will take up other arrangements.

Fig. 14 gives

the results of tests on glass cylinders of different lengths, the axes in all cases normal to the plane electrodes. Arc-over strength (kv/cm. effective) increases when the length of sample diminishes. The values are for a constant relative humidity of 60%. For comparison, a curve for air alone, recalculated to the

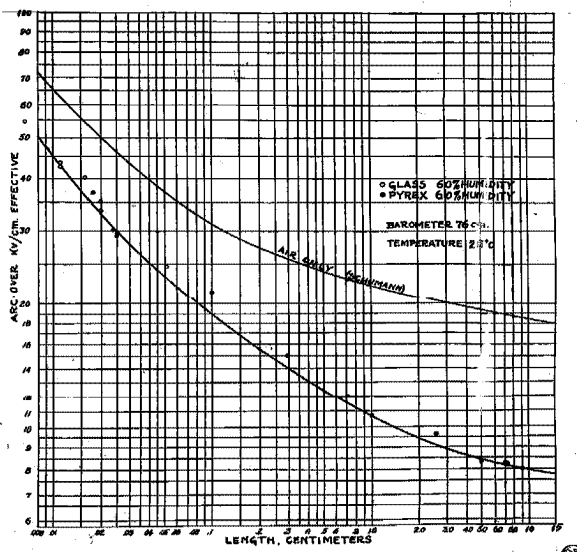

INFLUENCE OF LENGTH
Fig. 14

standard conditions of 76 cm. pressure and 25°C, is plotted on the same sheet. This curve is a composite of the values found by many different experimenters and compiled by

Schumann¹. The original was presented for conditions of 76 cm. pressure and 20°C. It has been converted to standard conditions for the present use. A copy will be found in Schwaiger's Elektrische Festigkeitslehre, Second Edition 1925 opposite to p. 474.

The diameter of the sample was found to have no effect even down to a fibre .02 mm. diameter. Rice and Schwaiger each state this general conclusion although neither of them actually tested samples much less than 1 cm. diameter.

A glance at Fig. 14 will show that not only does the arc-over strength increase very materially as the sample is made shorter but an .01 cm. glass sample at 60%

humidity has more than twice the arc-over strength of the air gap alone for 1 cm. length. Note that this does not mean voltage. It means volts per centimeter.

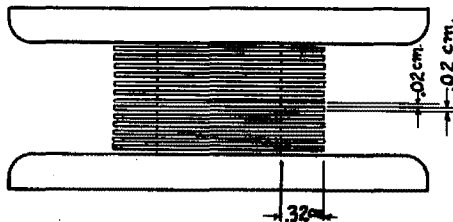

Suppose, then,

that a stack of alternate samples of glass, say 1.9 cm. and 2.5 cm. diameter, respectively, (Fig. 15)

EFFECT OF GROOVES
(Magnified)
Fig. 15

1. W. O. Schumann "Elektrische Durchbruchfeldstärke von Gasen" 1923, Springer.

each .01 cm. long (thick) be arranged between plane electrodes, the entire stack being 1 cm. high. Each large diameter piece will act as a series dielectric of high permittivity. The air spaces between will be stressed from 5 to 7 times as much as the glass. For rough calculation, suppose the glass acts as a conductor and puts the whole voltage upon the thin air films. The total length of air film is .5 cm. (taking them all in series). The stress on the air in these annular gaps between pieces of larger diameter is thus roughly twice the stress on the air between the main electrodes elsewhere in the main gap. But the curve shows that the thin films of air, even in contact with the glass at 60% humidity, are more than twice as strong as the air alone out in the space between the main electrodes.

The thin air-films cannot be broken down before the main gap punctures, which is what we want as the characteristic of high air-efficiency insulation.

One detail has been overlooked. Will not the edges where the thin air-film broadens out into the larger space produce some high field effects due to sharp points and edges? With metal spacers as assumed in the rough calculation, yes; but with glass spacers -- test will show.

Unfortunately, not enough of the very thin microscope cover glasses were available to make a stack 1 cm. high. Stacks of thicker ones were assembled and tested as shown in Table II. The results seem to give some promise.

Tests on stacks with metal spacers, however, are unsatisfactory.

Electrode Spacing cm.	Thickness of Glass disks cm.	Arc-over kv/cm. effective	Per cent Relative Humidity	Arc-over for glass cylinder of same total length kv/cm. effective. 90% humidity.
.102	.02	23.0	90	15.0
.142	.02	23.7	90	14.3
.183	.02	22.3	90	13.8
.233	.018	21.8	90	13.2
.304	.02	20.5	90	12.6
.90	.02	19.2	90	10.5
.90	.025	17.3	90	10.5

DISKS OF ALTERNATE DIAMETER
Table II

It has been shown, in this section, that length of path in the case of flat parallel electrodes and a sample whose axis is normal to the electrodes is all-important in determining the surface gradient of arc-over. Diameter of piece has no influence. Shape of surface may be extremely important. Grooves are beneficial if their dimensions are of the order of .01 to .02 cm. width. Larger grooves may be of value where the ridges are rain sheds or dust shields but, because of the higher stress put upon the air in the groove, are not to be recommended for surfaces whose arc-over gradient must approach the puncture strength of air.

SHAPE OF ELECTRODES -- FARADOID PRINCIPLE

In engineering practice, the flat electrode is scarcely ever used although the high voltage condenser bushing for transformers and switches when provided with

a large "hat", approaches that type of arrangement quite closely, at least as regards arc-over stress along its surface.

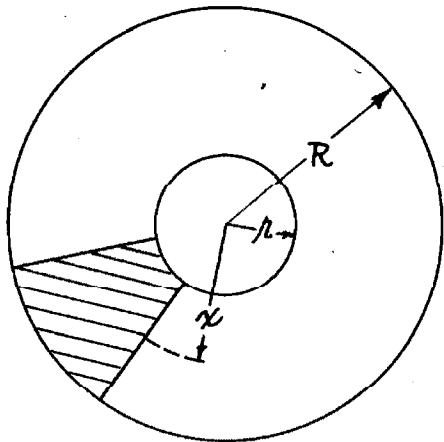

COAXIAL ELECTRODES
Fig. 16

For electrodes of all other shapes, no matter what the shape of the insulation surface, the arc-over gradient is non-uniform.

One arrangement in particular is of interest because its results can be generalized to some extent. Fig.

16 illustrates a pair of coaxial tubular electrodes.

The insulation is so disposed that its surface is parallel to the electric field, the effective voltage gradient at any radius x being

$$(1) \quad \frac{dv}{dx} = \frac{V}{x \log_e \frac{R}{r}}$$

where V is the total effective voltage between electrodes. It is evident that the effective gradient is greatest at the surface of the smaller electrode. Putting r for x in formula (1)

$$(2) \quad \left(\frac{dv}{dx}\right)_{x=r} = \frac{V}{r \log_e \frac{R}{r}}$$

In order to compare the coaxial arrangement with the homogenous field, some dimension corresponding to length of sample must be used. Since the gradient in the

former case is non-uniform, it seems logical to take its greatest value and determine the length of path over which V in a uniform field would produce the same gradient. That fictitious length has been designated "equivalent length" L' .

$$L' = \frac{\frac{V}{V}}{r \log_e \frac{R}{r}} = r \log_e \frac{R}{r}$$

If $R-r$ is some fixed value, it can be shown that L' approaches $R-r$ as these radii become very large. Fig. 17, taken from Schwaiger¹, contains both puncture

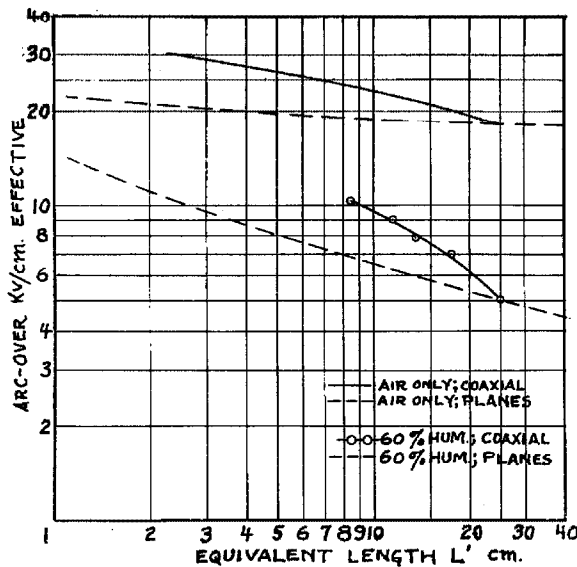

NON-UNIFORM FIELD (Schwaiger)
Fig. 17

strength of air and arc-over strength of porcelain as they are influenced by L' . The data is for a constant relative humidity of 60%. Obviously, only one value of $R-r$ can be expressed by a single curve. The value chosen is 25 cm. which is large enough to fit a good many practical insulators. The dashed curves show corresponding puncture and arc-over strengths in homogeneous fields.

1. A. Schwaiger "Die Überschlagfestigkeit des Porzellans" ETZ 26 June 29, 1922, Fig. 2, P. 876.

It is not surprising that such an increase in arc-over strength occurs, in view of the sphere gap tests of Peek¹ and his results for parallel cylinders. In those tests, the air films close to curved electrodes exhibit much greater puncture strength (kv/cm) than the air farther away from the electrodes. An explanation for this will be found in the APPENDIX.

These curves have been reproduced here because of their relation to the Faradoid principle, which, as previously described, requires that all exposed (not in contact with the electrodes) insulation surfaces be coincident with either the flux lines or the equipotential surfaces of the electric field. To be strictly unambiguous, the Faradoid principle must require smooth contours, for any groove or ridge whatever introduces dielectrics of different permittivity in series. If the walls of the groove follow an equipotential surface and the neighboring groove is very close, i.e. flange between two grooves, is of negligible thickness, the requirements are satisfied. Practical construction, however, requires flanges of considerable thickness and their extremities cannot merge into the other dielectric medium without disturbance of the ideal flux distribution. Therefore, only smooth contours can, in practice, be Faradoidal.

At least one insulator constructed upon this principle (Fig. 4) has been shown to be inferior to a near-

1. Op. cit.

ly similar one constructed (Fig. 5) in a non-Faradoidal manner. Of course, most non-Faradoid insulators will be far less successful than the authorized version.

The question is, how can one design the best shape of insulator to fit a given pair of electrodes, or even so modify the electrodes as to secure the very best air-efficiency possible in the space available?

It seems unwise to attempt to include in this report a working method for the design of insulators. Perhaps a few suggestions based upon the forgoing observations will be of value.

1. As a first approximation, the Faradoid form is unquestionably the best.

2. For ordinary humidity conditions, it may be assumed that the arc-over strength of a surface parallel to a uniform field is $2/5$ the disruptive strength of air for the same length of path, Fig. 14.

A surface parallel to a non-uniform field will have a somewhat greater arc-over strength, the value of which can be estimated by reference to Fig. 17. Equivalent length of path L' has been given as

$$L' = r \log_e \frac{R}{r}$$

where R is the larger radius of a concentric electrode arrangement and r is the smaller. In the practical problem, the highest gradients almost invariably occur next to the electrodes. The value of r is thus the radius of

the electrode in question. Reference to the curve will give an idea of the increased arc-over strength.

3. In a clean location, free from rain, fog, dust of vapors other than pure water, grooves will be practically valueless unless their dimensions are of the order of .01 to .02 cm.¹ The length of path is not increased by the flanges because just outside their edges, the path is much the same as before. Inside the grooves, the arc-over stress must be greater than for no grooves because part of the otherwise useful length of surface is occupied by flanges whose permittivity is greater than that of air and the voltage drop consequently less, Fig. 1. Experiment shows that flanges are either detrimental or have no effect whatever in the case of clean insulators subjected to ordinary humidity conditions.

4. In the case of insulators partly covered by water drops, dust, salt crystals, etc., flanges act as rain sheds, dust shields and increased length of path. A clean portion of the surface is usually sheltered from contamination so that its arc-over strength is maintained², while the dirty portion of the surface acts as a series resistance and not a dielectric. It is^a well known fact that puncture

1. See page 22.

2. It may be well to, at this time, mention the H. B. Smith round rod type of insulator for high voltage lines (AIEE 43 p.1263,1924). It consists of a long wood rod capped by metal plates to provide uniform field. Perhaps its lack of success is due to the absence of flanges.

voltage of solid dielectrics is very greatly increased by inserting resistance materials in series with the dielectric. A similar effect seems to have an influence in the case of insulator arc-over.

Schwaiger¹ found that large commercial pin-type insulators had increasing arc-over voltages as the relative humidity of the surrounding air increased from 30% to 95%, falling off sharply in the rain tests but not falling below the value corresponding to 30% humidity. He further found that medium size insulators of the same type behaved in a similar manner but showed a less exaggerated effect. Small pin-type insulators arced over at voltages independent of humidity up to the rain test in which the arc-over voltage fell off considerably. Littleton and Shaver² have observed that a Pyrex rod around which were twisted two pieces of No. 6 copper wire about 14 inches apart, for electrodes, arced over at voltages increasing with absolute humidity. It is pointed out in explanation, that in all of the above cited cases, at least one electrode was a piece of small diameter (perhaps 2 or 3 mm.) wire. The effect of the increase in humidity was probably to increase the equivalent size and curvature of the electrode as well as furnish a series resistance in place of a dielectric between the electrode and the

1. Elektrische Festigkeitslehre, 2nd Ed., p. 424, Fig. 421.
2. J.T. Littleton, Jr. & W.W. Shaver of "The Effect of Humidity on Dry Flashover Potential Pin-Type Insulators". Quarterly Trans. AIEE 47 p. 438, April, 1928.

remaining portions of the insulator. Anything which will tend to relieve arc-over gradient in the places where it is most severe is almost sure to increase the total arc-over voltage.

5. It may be inferred from the foregoing that modifications of the Faradoid form can be made to advantage. Such is the case as has been seen.

There is nothing miraculous about the Faradoid principle. It seems to have been first applied to the mathematical system of two confocal hyperbolic cylinders as electrodes producing confocal ellipses as flux lines. Such a system was many years ago analyzed by Maxwell¹. The electrodes are ordinarily of large radius of curvature and probably no better contour of the insulation can be found than that following the flux lines. Other shapes of electrode may, however, not comply with the requirement of large radius of curvature. Such is the difficulty with the rod-and-ring bushing illustrated in Figs. 4 and 5. Both the rod and the ring have small radii of curvature (1 cm.). Employing a Faradoid shape of insulation in the way in which it has been done, places a severe arc-over gradient upon the air immediately in contact with each electrode. In spite of a somewhat higher arc-over strength observed when insulation is used in such a way, the gradient at the electrodes far exceeds the arc-over strength even before the larger part of the

1. Op. cit.

insulator surface is near arc-over. The remedy is to remove some of the insulating material, as was done. See Fig. 5. Flux refraction now redistributes the gradient so that its value at the electrode surface is reduced, and an increase occurs in a location much under-stressed originally. Fig. 18 is not an exact plot but serves to illustrate the contrast

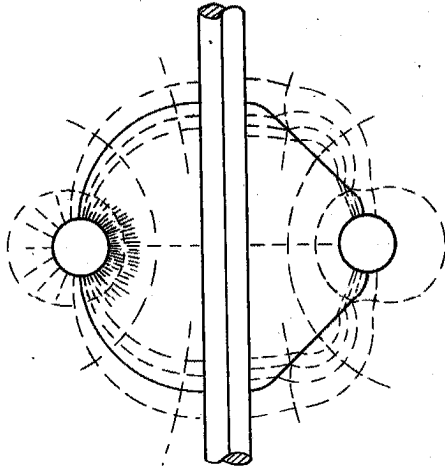

FLUX REFRACTION
Fig. 18

brought about by the modification in shape.

In order to determine just how far to go in making such a change in contour, electric flux maps must be plotted. The mathematical theory applies to only a few special cases.

Suggestions for flux

mapping in the case of a three dimensional region having symmetry about one axis of rotation will be found in Moore¹. Additional complication arises due to flux refraction but the ratio of angle of approach to angle of refraction is easily computed and a table for every 5 degrees, say, can be made out and used to advantage. The equipotential lines must intersect the flux lines orthogonally, hence they, too, will suffer refraction but in the inverse direction, bending toward the normal.

The best insulator contour, then, for a given service can be approached by a very difficult and tedious,

1. A. D. Moore, "Fundamentals of Electrical Design", First Ed. 1927, McGraw-Hill, p. 61-67.

to be sure, method of mapping, in which such factors as conduction surface due to rain, abnormal arc-over strength due to curvature of electrode and modified gradients due to flux refraction are taken into account. In this connection, it must be emphasised that flux refraction in a dielectric circuit does not always increase the stress on the air. It does, however, always make the solution of the problem more complicated.

CONTAMINATION OF A SURFACE

Perhaps the most striking effect of the kind encountered in this investigation occurred in the vacuum vessel in which a Pyrex sample was being prepared for the arc-over test at zero humidity. A temperature of about 400°C was maintained for more than an hour simultaneously with the vacuum. The copper electrodes shed their oxide coating due to the elevated temperature, some of the oxide being deposited upon the walls of the enclosing tube and some upon the sample. When the test was made, an arc-over voltage of less than 80% of the anticipated value was found. The quantity of foreign substance involved was such as to be scarcely observable, showing up as a very slight darkening of the ordinarily bright surface.

Another type of surface contamination and one that should be carefully avoided in arc-over experiments, is that due to Oxide of Nitrogen formed by the arc. In the presence of water vapor, it forms Nitric Acid which is a conductor and

reduces the arc-over strength by uncertain amounts up to, in my observations about 60%. Large volumes of fresh air in constant circulation seem to be the best remedy. Experiments carried on under a bell-jar were impossible when other than zero humidity conditions existed, unless the apparatus was to be completely dismantled and reassembled for each reading.

Oil vapor from an air pump used to bring air from outside the building into the test room caused very definite falling off of arc-over voltage after 40 or more hours.

Several experimenters have stated that such contamination as sputtered films of metal, dirt and the like invariably reduced arc-over voltage in a homogenous field. Fortescue¹, on the other hand, states that his rod-and-ring bushing (Fig. 4) had a constant arc-over voltage whether clean or coated with a three months' accretion of Pittsburgh atmosphere. In the latter case, surface conduction relieves some of the very high surface gradient at the electrodes just as the increased humidity does in the case of Littleton and Shaver's Pyrex rod.

Some foreign substances are beneficial even in the uniform field arc-over tests. Rice² found that a coating of transformer oil on glass and hard rubber increased the arc-over voltage 30 or 40 per cent. His experiments were carried out in atmospheres of less than 50 per cent relative humidity. I have found that washing a glass or Pyrex sample with Proctor & Gamble "Lava" soap and drying

1. G.L.Fortescue, Discussion, Trans.AIEE 36, 1057 (1917).

2. Loc. cit.

thoroughly with a paper towel yields arc-over voltages in a uniform field corresponding to low (10%-25%) relative humidity, regardless of the humidity of the atmosphere in which the test is made. The soap contains one or more vegetable oils which remain on the glass even after brisk rubbing. The film of oil is, in this case, so delicate that one spark is sufficient to destroy it even though the spark passes several mm. away from the sample and endures for only a second. Such a coating of oil has been observed to resist the effect of 65 per cent relative humidity of the atmosphere for 24 hours and still yield an arc-over test close to the strength of air alone.

JOINTS

The influence of very thin films of air—or other substance of lower permittivity than the sample under test—between electrodes and sample, is an uncertain quantity. All of the tests herein reported, excepting those credited to other experimenters, have been made on samples which had their ends ground off quite flat, no chamfer being made to remove the sharp edge where longitudinal surface and end meet. The electrodes have been turned flat in the lathe and ground or polished down to quite accurate planes. For example, the 20 inch diameter (51 cm.) aluminum electrodes used in testing the longer samples (2.46 cm. and longer) were turned and polished to better than .002 cm. maximum deviation from perfect planes. Thus, a very good fit has

been secured between electrode and sample. The upper electrode rested freely upon the sample, no surrounding frame being used to guide it. In the tests of the very thin samples (microscope cover glasses) the electrodes and sample were placed in a Bakelite frame so as to permit a force to be exerted upon them—an attempt to secure good joints. In the zero humidity tests, both electrodes were guided by suitable parts of the glass vessel but the guiding was loose enough so as to permit them to make full contact with the sample, a Tungsten spring forcing them against the latter with a force of roughly 300 grams. Table III shows to some extent the influence of joints.

Per cent Relative Humidity	Length of Sample	Arc-Over Voltage, effective	
		Ends flat	Ends Chamfered (Thatcher ¹)
60	9.3 cm.	95 kv.	88 kv.
60	7.2	76	--
60	5.0	55	52
60	2.46	31	26

Table III. EFFECT OF JOINTS — PYREX

Rice² adopted a scheme in which he depressed the electrodes so as to obtain electrostatic shielding of the

1. J. W. Thatcher, Master's Thesis. The chamfer was about 1 to 1½ mm. and the sample was in contact with the electrode at only a few points. Perhaps .01 to .05 mm. air gap could be assumed.
2. Loc. cit.

joints between his glass tubes and electrodes, Fig. 19. This has the objectionable feature of giving increased length of path to the test piece and invariably increasing the arc-over voltage. One cannot be sure whether the in-

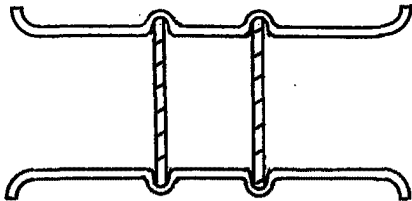

SHIELDED ENDS
Fig. 19 (Rice)

creased voltage is due to longer sample or better joint. The relation is not merely one of accounting for the additional length of path. The electric field symmetry is disturbed.

It is felt that the problem of joints was not completely solved in this investigation but short of producing optical flats on both sample and electrode and eliminating absolutely every fleck of dust from the joint, no better solution was found. Waxes creep up along the useful insulating surface due to the heat of the arc. Mercury will squeeze out, forming a new part of the electrode having small radius of curvature. Any manner of fitting the sample into a depression in the electrode effectively lengthens it.

DIELECTRIC CONSTANT

The permittivity (dielectric constant) of the solid insulation may exert a small influence on its arc-over voltage in air. Table IV illustrates the results obtained on samples of different substances which are nor-

Rel. Hum.	Kv/cm. effective, Arc-Over Voltage—Length 1.02 cm.						
	Bond paper Strip .01 X 1.0 cm.	Bond paper Stack 2.5 X 2.5 cm.	Quartz Fibre .01 cm.	Pyrex Fibre .001 cm.	Cellophane Strip .0025 X 1.0 cm.	Waxed Paper Strip .004 X 1.0 cm.	Mica Strip .02 X 1.0 cm.
60	21.0	20.7	20.5	15.5	12.0	18.4	12.6
80	20.2	19.2	20.0	---	---	18.5	10.8
90	18.0	19.2	19.8	---	---	10.8	10.0

INSULATORS OF DIFFERENT DIELECTRIC CONSTANT
Table IV

mally of small dimensions. Figs. 20 and 21 show the test equipment which was employed in all of the above determinations.

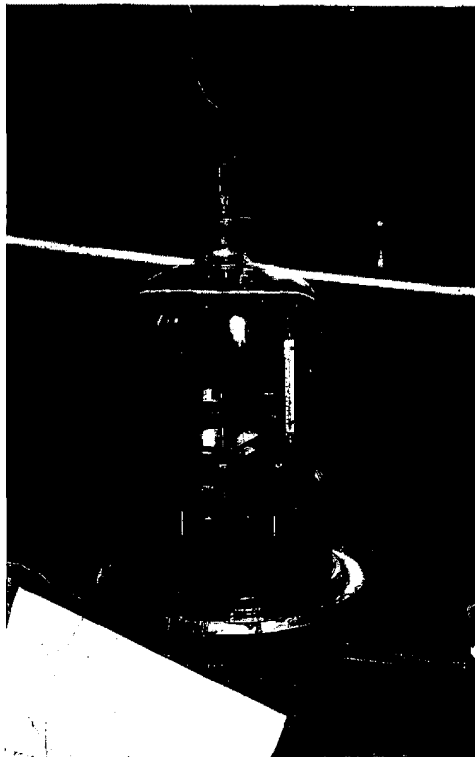

ASSEMBLY
Fig. 20

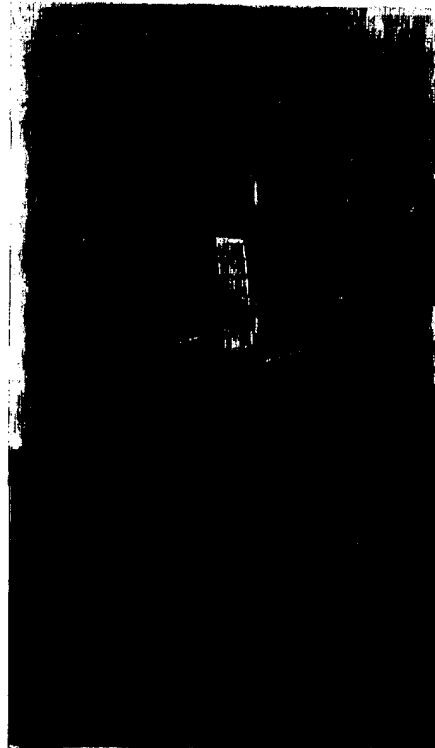

DETAIL OF ELECTRODES
Fig. 21

It is impossible to decide, from the limited data, whether the increased arc-over strength of the paper and quartz fibre is due to low permittivity or some surface characteristic. The paper was a "Bond" variety 0.1 mm. thick and the strip 1 cm. wide. The stack was of 2.5 cm. squares of the same paper not very tightly pressed together (approximately 100 grammes). The quartz fibre was 0.1 mm. thick, untreated after manufacture in an oxy-gas flame about two days before installing in the test gap. The results in Table IV for paper and quartz represent many arc-overs of the gap during three days at 90% relative humidity, for each sample.

The paper absorbed moisture freely. Although it was installed with a slight tension, a bow soon appeared in the strip and, when exposed to 90% relative humidity, the length seemed to have increased 20 per cent.

ABSORBENT QUALITY

Table IV, in the foregoing section may throw some light upon this phase of the problem. There seems to be no relation between the absorbent quality of the material and its change of arc-over strength with relative humidity of the atmosphere.

Glass is known to decompose on the surface when exposed to moist air. Silica-gel is formed. It is extremely porous, the pores being for the most part sub-microscopic. It is now a well known drying agent and absorber of vapors and gases.

Paraffin and lac (the raw material from which shellac is made) have moisture resisting surfaces.

Paraffin, lac, porcelain, Pyrex and glass (see Figs. 6, 7, 8, 9, 10) all show strikingly similar response to the humidity of the surrounding air.

Paper, the most absorbent of all, seems to suffer very little in arc-over strength, quite in contrast to glass, paraffin, etc.

Cellophane, moisture resisting substance, has a very low arc-over strength even in an atmosphere of only 50% relative humidity.

SURFACE RESISTANCE

In an attempt to get somewhat more conclusive information on the influence of surface resistance than any thus far discovered in the literature, a rather elaborate system of shielding, interlocking switches and small current measuring apparatus was set up. Fig. 22 shows in diagrammatic form, the essential parts exclusive of the high voltage transformer from which arc-over voltage was obtained.

It was desired to measure surface resistance and arc-over voltage (without changing the location of the sample and consequently its contact with the electrodes). The procedure was as follows:

With shields A and B in place, totally enclosing the lower 20" diameter (51 cm.) electrode, the latter

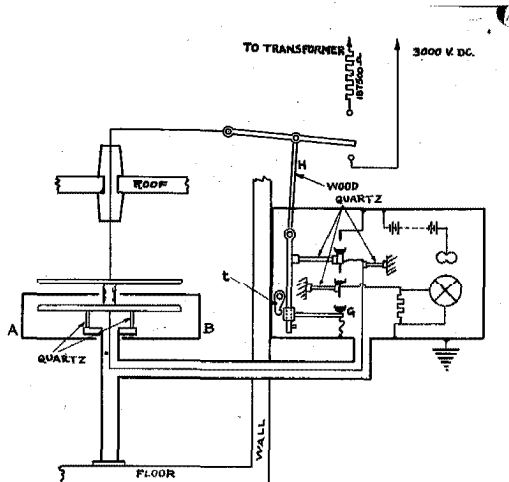

RESISTANCE MEASURING EQUIPMENT
Fig. 22

which time the system "charged up" to steady conditions, a small trip catch *t* was released, opening the grounding switch *G*. The electrometer, then in series with the lower plate, indicated the leakage current due to the sample under test.

The next operation was to throw the high voltage switch over to the transformer position, simultaneously, of course, due to the interlock, switching the electrometer out of circuit, "shorting" it and putting a ground on the lower electrode of the test specimen.

By means of a pulley arrangement, the two halves *A* and *B* of the shield covering the lower electrode were removed

grounded, 3000 Volts D.C. was applied to the upper electrode by means of the single pole, double throw, high voltage switch. An interlock *H* caused the electrometer with its calibrated shunt to be (at the same time) connected to the lower electrode's grounding circuit, switch *G*, only, remaining closed to maintain the "ground". After a second or so during

to a safe distance and the sample was then ready to have high voltage applied from the transformer. Arc-over voltage was read.

If the procedure were reversed and arc-over taken first, a polarization of uncertain magnitude and direction seemed to be present and spoiled the resistance measurement. After ten minutes, it disappeared and readings were easily obtained.

Fig. 23 is a combined plot of surface resistance, upper curve, and arc-over kv/cm. effective, lower curve, as

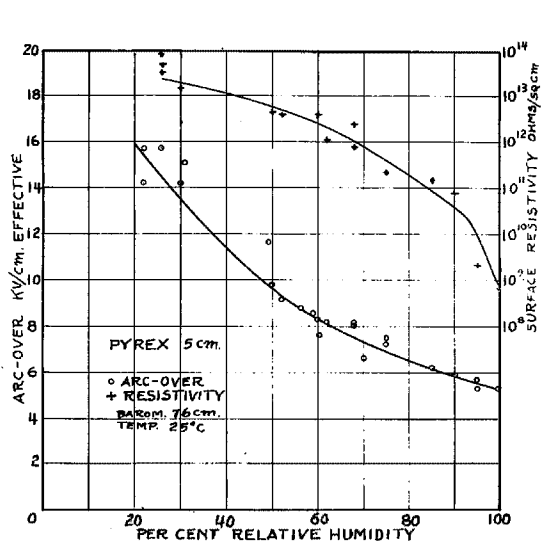

**SURFACE RESISTANCE &
ARC-OVER STRENGTH**
Fig. 23

influenced by relative humidity. No apparent relation exists between them. A more striking illustration than the curve is a group of individual readings, Table V.

The data usually presented in justification of the statement that no relation exists between surface resistance of a solid insulator and its arc-over voltage in air consists of the two sets, (1) Curtis' surface resistance data¹ for paraffin which shows the surface resis-

1. H.L.Curtis, Bul Bureau of Standards, Vol. 11, p. 359, 1915, also G.E. Rev. 18, 996 (1915) and El. Wld. March 18, 1915.

Time	Per cent Relative Humidity	Surface Resistance Ohms	Arc-Over kv/cm. effective
11:06	54	13.5 X 10 ¹²	9.0
11:16	56	9.6	8.6
11:29	57	4.8	8.75
11:37	60	4.4	8.05
11:45	61	3.4	8.1
11:56	62	2.0	8.75
12:09	63	1.55	9.45
12:24	65	1.48	9.35
12:37	67	1.55	9.2
12:52	69	1.4	9.87
1:02	70	1.3	10.5
1:13	70	1.3	9.85
1:21	71	.84	9.35
1:31	68	.9	8.5
1:46	65	1.3	7.9
2:01	63	1.2	9.4

A SAMPLE OF DATA
Table V

tivity to be almost independent of relative humidity of the surrounding atmosphere, and (2) an arc-over curve for paraffin, Fig. 10, 12a. Inspection of Curtis' curves, however, shows the points to be erratic, probably due to accidental coming together in puddles, of the minute droplets of moisture ordinarily kept separate by the greasy nature of the paraffin surface. One might expect a still greater lining-up of the droplets under the influence of the high field in the arc-over test. In other words, the surface resistivity of paraffin just before arc-over may be quite different from the experimental value in a low voltage test such as Curtis made. Glass, on the other hand, should not be expected to show that phenomenon because its surface moisture is pictured

as being absorbed in the silica-gel.

R. J. C. Wood¹ has presented some interesting arc-over data on large commercial insulators—suspension units and post-type, all porcelain—in which the surface became almost entirely coated with crystalized salt from a natural sea water spray. On clear days, the insulators were dry, but they became moistened by fog on frequent occasions. Voltage close to arc-over was maintained day and night, a 1 ampere fuse in series with the insulator acting as an indicator of occurrence of arc-over. It can, as an approximation, be assumed that the surface resistivity per square inch or square cm. is uniform over the entire insulator surface, so completely does the salt coating cover it. A value of total surface resistance was calculated by Mr. Wood for each of the insulators tested (assuming uniform surface resistivity) and the arc-over voltage found to be quite consistently proportional to that resistance. Pyrex cylinders tested in uniform fields in the present investigation, when coated with a generous deposit of salt by spraying sea water upon them, after which they were dried and again moistened with a spray of fresh water while voltage was applied, yielded an arc-over voltage close to that predicted on the basis of Mr. Wood's "Surface leakage resistance". See Table VI.

1. Quarterly Trans. AIEE 49, p. 9, January, 1930.

Time	Surface Condition	Arc-Over kv. effective	"Surface Leakage Resistance" Lgth.+ Cir.	Expected kv. effective of Arc-Over (R.J.C.Wood)
10:05 10:10	Salt coating, Dry	10.3 12.5	---	---
10:15 10:16 10:17	Salt coating, Moist	5.8 5.0 4.2	.35	5.0 to 5.2
10:20 10:22 10:27	Salt coating, Sprayed with fresh water	7.5 8.3 7.5	---	---
5.03 5.08	Cleaned by Spray; Dry	30.0 29.2	---	---

BEHAVIOR OF 4.6 CM. DIAM. X 5.1 CM. LONG PYREX CYLINDER. PROTECTIVE RESISTANCE 18500 OHMS.
Table VI

It is not true that under ordinary humidity conditions, insulation has an arc-over strength proportional to surface resistivity or universally obeying any other law, but in a uniform field, low surface resistivity invariably predicts low arc-over strength. In a non-uniform field, however, the effect may be reversed, due to enlarging of the active electrode surface and the substitution of series resistance for series capacity (see page 29), up to a certain limit which seems to be the condition of about 90 per cent humidity. Beyond that, a reduced surface resistivity invariably reduces arc-over strength in any kind of a field.

ROUGHNESS

It has been suggested by at least one experimenter that the diminished arc-over strength of an insulation surface in a uniform field as compared with the same path in air alone is due to sharp points of macroscopic or microscopic dimensions, water droplets, also, being pictured as the equivalent of points. That such is not the case is evidenced by the lack of dependence of the arc-over strength of Bond paper on relative humidity, Table IV. Samples of Pyrex rod, both highly polished, and quite badly pitted, arc-over at so nearly the same voltage gradient that no definite distinction can be made between them. It was noticed on many occasions that nicks, scratches and other flaws in samples had no influence upon the path of the arc. Only accidentally did the arc occur close to the location of the flaw.

The fact of augmented arc-over strength, characteristic of surfaces next to sharp points, in very narrow grooves and like situations¹, seems to indicate that at any rate in homogenous fields, no such influence of points and scratches should exist as has been supposed.

Schwaiger² finds that in the case of Carta and Durax, the former a molded paper and the latter a molded

1. The exact details of the information presumed here have not been presented but Figs. 14 & 16 will illustrate the principles.
2. Überschlagfestigkeit des Porzellans E.T.Z. 26, June 29, 1922, p. 879.

conglomeration, roughening the surface by means of sand paper made no appreciable difference in the arc-over voltage.

Systematic irregularity such as very narrow grooves with flanges of comparable thickness is a source of greater arc-over strength, Table II.

IONIZATION

According to the theory of sparks which was suggested by Townsend¹ some initial ionization of the air is necessary to start a spark in air. It was thought that a greater consistency of readings and perhaps a lower value of arc-over gradient would be found if Ultra Violet light were caused to fall upon the sample, the electrodes, or both. A Quartz-Mercury arc was, accordingly, set up, the light being first directed upon the Pyrex sample, in another test, upon the lower electrode, and finally, upon the entire assembly. The intensity of the light was not measured but the 3 ampere Quartz-Mercury tube was placed only about 75 cm. away from the sample under test.

At atmospheric pressure, the presence of the Ultra-Violet light made no noticeable change in the arc-over voltage or uniformity of readings. The effect was tested over a range of 40% to 70% relative humidity, results being practically the same as without the Quartz-Mercury tube. More powerful sources of ionization were not used.

1. Op. cit.

TEST VOLTAGE AND METHOD

In all of the foregoing work, sine wave voltages, or very closely so, were employed. For samples of length of .7 cm. and greater, the high voltage supply was a 250 kva., 250 kv., 50 cycle transformer having one high voltage terminal grounded; the voltage controlled by means of a Westinghouse Regulating Transformer built for the purpose. As a protective resistance in the high voltage circuit, ten Zircon resistance rods totalling 187500 ohms were employed, unless otherwise noted. A calibrated voltmeter winding in the main transformer was used to determine the voltage.

For samples of shorter length than .7 cm., a 1 kva. 6.6 kv. 50 cycle transformer was used and a protective resistance of 35000 ohms. There were four 110 volt primaries. A motor-driven induction regulator was employed for voltage adjustment of this transformer. Arc-over voltages were read through the agency of an instrument potential transformer rated 5000/2500/125 volts and a 10, 30, 75 or 150 scale a.c. voltmeter whichever was most convenient.

Speed of voltage rise in the use of the 250 kv. transformer was about 5 to 5.5 kv. per second. It was brought up to arc-over without intermediate stops in the case of samples of 5 cm. length and greater, i.e. voltage application to the sample was at the rate of about 10% of arc-over voltage per second.

In the case of the shorter samples, some inter-

mediate stopping was necessary because the rate of travel of the regulator was fixed within rather narrow limits and was too fast for good work. About 5 to 10 seconds usually sufficed to arrive at arc-over value.

The occurrence of the arc for the longer samples was observed by the use of a telephone head set inductively coupled to the ground wire. This gave the observer opportunity to devote all his attention to the voltmeter. For the shorter samples, either a mirror was so located that both arc and meter needle could be observed at the same glance or the observer watched the sample with one eye and the meter with the other! Frequently, two observers worked to good advantage. Lastly, on the tests of very short samples, current enough was drawn by the arc to appreciable "dip" the voltage. The observer could then work as conveniently as when using the phones. Noise from the transformer and regulator made most audible observations of either the arc itself or its duplicate in the phones, difficult in the case of lower voltages.

Relative humidity was controlled somewhat by introducing trays of water into which paper or rags dipped and increased the evaporating surface, a fan aiding in the process. The natural weather provided a range from 10% to 100% relative humidity but it was unfortunately not constant for sufficient time to permit the sample to adjust itself. Some difficulty was experienced from lack of constant

humidity. Two different methods of measurement were used. For the larger samples and higher humidities, there were fixed wet and dry bulb thermometers in the air stream from a 10" electric fan. For work under the bell-jar and for the lower humidities, a "precision" hair hygrometer of laboratory type proved quite satisfactory. In the case of zero humidity, liquid air and Anhydrone were relied on to extract moisture to a degree negligible, at least for the present purpose.

SUMMARY AND CONCLUSIONS

With regard to air-efficiency (the efficiency of utilization of air as an insulator in combination with solid bodies), the total of useful arrangements may be divided into three classes, (1) those in homogenous electric fields which follow the contour of the insulator, (2) those in non-homogenous fields which follow the contour of the insulator, and (3) all others.

Class 1. Exhibit arc-over strength (kv/cm.) —at atmospheric pressure and ordinary temperature—dependent upon total length of surface in the direction of the field, relative humidity of the surrounding atmosphere, to a lesser extent upon nature of the substance in question, and upon the treatment (clean; foreign matter adhering to or penetrating the surface) which the surface has received.

The best air efficiency (100 per cent) must be

assigned to perfectly clean, dry samples in an atmosphere of zero humidity. The arc-over gradient is equal to the disruptive strength of air at the same pressure and temperature and length of path.

Other characteristics which fit equally all three classes will be added at the end.

Class 2. Exhibit arc-over strength (kv/cm.)— at atmospheric pressure and ordinary temperature—dependent upon "equivalent length", i.e. such a length as will withstand the total arc-over voltage at the actual greatest gradient, provided the gradient were uniform.

$$\text{Equivalent length} = V / \left(\frac{dv}{dx} \right)_{\text{max.}}$$

[Crest value of the a.c. sine wave must not be confused with maximum gradient. The latter means maximum with respect to location along the insulator surface]. Other factors upon which arc-over strength depends are the same as for Class 1 but the effect of a particular factor may be different.

The best air-efficiency (100 per cent) is to be assigned to only one special case, coaxial tubular electrodes and perfectly clean, dry sample in zero humidity atmosphere. All other shapes of Class 2 including most of the non-flanged Faradoid insulators have less than 100 per cent air-efficiency even when perfectly dry. (Flanged Faradoid insulators come under Class 3.) Other character-

istics which fit equally all three classes, will be added at the end.

Sometimes it is observed that Class 2 insulators (other than coaxial electrode type) have their arc-over voltages increased, or at any rate, unchanged by the presence of moisture, dirt, etc. They seem to just go over the line into Class 3 as regards influence of conducting substances on their surfaces.

Class 3. Involves dielectrics of different dielectric constants in series. It further involves all manner of flux refraction which must be studied in individual cases, usually, however, resulting in increased dimensions being required, hence insulators in Class 3 can never attain 100 per cent air-efficiency. There is one exception, the insulator with flanges and grooves of dimensions .02 cm. and less.

All three classes with possibly special exceptions for very small diameter electrodes in Classes 2 and 3 have arc-over voltages proportional to relative air density whether changes in density are due to pressure or to temperature changes.

Surface resistance is an important factor but its influence is not convertible from substance to substance nor from one class to another. Lower surface resistance is, in general, detrimental to insulators in Class 1 and favorable to those in Classes 2 and 3.

The moisture absorbing property is more uncertain in its influence than is surface resistance.

A film of oil, not contaminated by dust, is usually a benefit in Class 1 insulators.

Dielectric constant has no great influence excepting where air is to be in series with a solid dielectric.

Ionization has no appreciable influence.

Surface roughness has no appreciable influence, but it has been discovered that systematic irregularities such as grooves of .02 cm. or less, separated by flanges of like dimension, when placed at right angles to the field lines, improve the arc-over strength for humidities other than zero.

Metal inserts of any kind are a study by themselves.

The air-efficiency of insulation depends upon the condition of its surface, the amount of moisture in the air, the shape and arrangement of electrodes and insulation surface. The arc-over strength of insulation depends also upon the disruptive strength of the air itself.

APPENDIX

That cumulative ionization by collision, including ionization by positives, is responsible for sparking in gases¹ is now an established fact. W. Rogowski² has recently shown that the process is completed (when the required field exists) in the incredibly brief time of 10^{-8} seconds. It is thus absolutely indifferent whether a.c. or d.c. is used for the field, so long as the crest value is known and the

frequency is less than of the order of 10^6 .

The only source of initial ionization here considered is the Cosmic Ray.

Little attention is usually given to deionization. It will, in the following treatment, be considered of prime im-

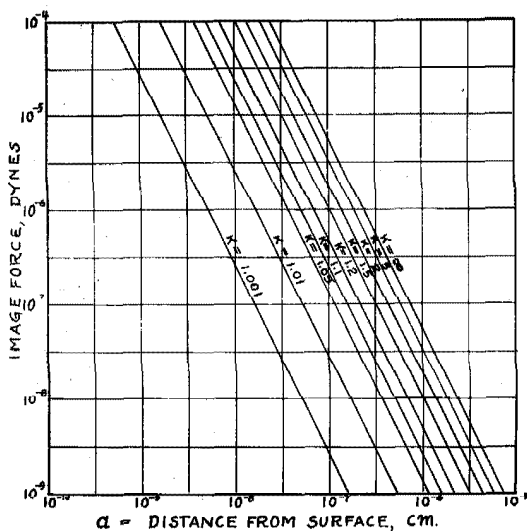

IMAGE FORCE DEPENDENT ON K
Fig. 24

portance.

Fig. 24 shows the values of the image force F

$$F = \frac{e^2}{4a^2} \frac{K-1}{K+1}$$

upon a charge e in air at a distance a from the infinite

1. J.S.Townsend, "Electricity in Gases" 1915, Oxford.
2. Zusammenfassung von W. Rogowski, Sommerfeld-Festschrift, 1929.

plane surface of a dielectric of permittivity K. The values of a which will be used are so minute that even a rough surface may be assumed to be composed of infinite planes at different angles.

The "field force" on a single ion in a field of 30 kv/cm. (usually taken as the disruptive strength of air) is

$$eE = 4.77 \times 10^{-10} \times \frac{3 \times 10^4}{300} = 4.77 \times 10^{-8} \text{ dynes.}$$

where E is the voltage gradient or field. Reference to Fig. 24 shows that for glass, ($K = 5$) the image force at a distance of 10^{-6} cm. from the surface is equal to the field force of the disruptive field for air. To be sure, 10^{-6} cm. is only one tenth of a mean free path for a molecule and less than one tenth of that for an ion, but the image force does not end there. It extends, in appreciable magnitude, to a distance of 10^{-5} cm. where it is 1 per cent of the field force. Due to the image force, free electrons and (+) ions are attracted toward the surface of the insulator, the electrons arriving much the earlier because of higher mobility.

We now have a (-) charge on the insulator, the (+)'s being still more strongly attracted. It is quite obvious that (barring space charge influences, which should be negligible in this region) a skin of 10^{-5} cm. thickness, covering the insulator surface, will be swept free of ions about as fast as they are formed. The (+)'s will combine

with (-)'s on the insulator surface, continually maintaining the (-) charge at an equilibrium value. All of the process just attributed to image force goes on, of course, independent of any longitudinal field imposed from without.

It is possible that the deionizing influence of a solid insulator in air actually improves, under favorable conditions, the disruptive strength of the air. The effect shown in Fig. 12, at pressures of two thirds atmosphere and below, is attributed to a deionizing influence of the insulator. Hence, the presence of the insulator is seen to improve the strength of the air.

Metals ($K \rightarrow \infty$) exhibit the largest possible image force. The negative surface charge which accumulates in the case of insulators may, in that of metals, be replaced by no charge, (clean surface) or (\pm) charge depending on the nature of the surface oxides, grease¹, etc. Whatever the sign of the characteristic surface charge, a cleaning-up effect as in the case of insulators takes place in the skin next to the electrode surface. No doubt such deionization is chiefly responsible for the surprisingly great puncture strength of very thin air films, (.02 cm. and less.).

Slepian² has made use of the deionizing power of

1. K. T. Compton and I. Langmuir, Rev. Mod. Phys, Apr.1930 and Apr. 1931.
2. J. Slepian, Trans AIEE 47, 1398 (1928).

metal sheets inserted into highly ionized gas to rapidly reduce the ion concentration for arc extinguishing purposes. He has found¹ that insulating substances perform a similar function. Thus far no mention has been made of moisture.

INFLUENCE OF WATER VAPOR

The phenomenon of the assembling of water droplets about an ion in air has been used in many important experiments. It requires no great stretch of the imagination to picture these droplets deposited upon the insulation surface by the moisture-laden ion traveling to the surface under its image force. After a definite quantity of water per sq.cm. of insulator surface has accumulated evaporation will prevent more from being held. Whether, in equilibrium, the quantity (grams per sq.cm.) is proportional to the relative humidity of the air or is some more complicated function, would at present be a mere guess.

At any rate, the air has supplied a "water-skin" (Wasserhaut) as the Germans call it, which shall be considered a source of ions-by-bombardment. That bombarding ions moving in the tangential field can have a velocity component (due to their image force) toward the insulator surface, has been shown. But it is not necessary for them to have even that component. No material surface is smooth

1. J.Slepian, Quarterly Trans. AIEE, 49, 421, April, 1930.

to molecular dimensions. Innumerable projections stand in the way of ions moving tangent to the main body of the insulator, and these projections have the same water-skin as though perfectly smooth plane surfaces.

It remains merely to show that water surfaces give up electrons more easily when hit by ions than do air molecules or solid surfaces. No data are available on relative ionization potentials of water and solids but spark gap and corona formation experiments by Peek¹ and others indicate that wet electrodes invariably give lower breakdown voltage than clean dry electrodes whether for spark, or corona.

The mechanism of arc-over of solid insulators in air is thus a process of dislodging electrons from water which was previously brought to the surface by water-laden ions moving under their image forces. When the air is free from moisture, arc-over of the solid body occurs at the same, or even greater (Fig. 12), value of field than is required when air only occupies the region.

Why the electrodes themselves do not accumulate a skin of water and show an effect of humidity in ordinary spark gaps is to be attributed to the fact that such a water-skin occupies only a minute part of the total length of spark path, whereas the same sort of skin in the case of the insulator occupies the entire length of path. Needle-

1. Op. cit.

points do show a slight increase of voltage with increasing humidity according to Peek¹, p. 117.

INFLUENCE OF DIELECTRIC CONSTANT

Dielectric constant has such a comparatively small influence upon the image force, Fig. 24, that it is not expected to be the cause of any observable changes in arc-over values.

REFERENCES

A New Type of Insulator for High Tension Transmission Lines by E. M. Hewlett, Trans AIEE 26 (2) p.1259, 1907.

Air as an Insulator when in the Presence of Insulating Bodies of Higher Specific Inductive Capacity, by C. L. Fortescue and S. W. Farnsworth, Trans AIEE 32 (1) p. 893, 1913.

The Application of a Theorem of Electrostatics to Insulation Problems by C. L. Fortescue, Trans AIEE 32 (1), p. 907, 1913. Discussion by J. Murray Weed, p. 940.

An Experimental Method of Obtaining the Solution of Electrostatic Problems, with Notes on High Voltage Bushing Design by Chester W. Rice, Trans AIEE 36 p. 905, 1917. Discussion by C. L. Fortescue, p. 1057.

1. Op. cit.

A Treatise on Electricity and Magnetism by J. C. Maxwell, Oxford.

Die Überschlagfestigkeit des Porzellans by A. Schwaiger E.T.Z. 26, p. 875, June 29, 1922.

Elektrische Festigkeitslehre by A. Schwaiger, 2nd Ed. 1925, Julius Springer.

Theorie der Hochspannungsisolatoren by A. Schwaiger, Elekt. u. Mach. 38, 1920.

Durchbruchfeldstärke von Gasen by W. O. Schumann 1923, Julius Springer.

Zusammenfassung von W. Rogowski, Sommerfeld-Festschrift, 1929.

Volume and Surface Resistivity of Insulating Materials by H. L. Curtis. G. E. Rev. 18 p. 996, Oct., 1915, also Bul Bureau of Standards, Vol. 11, p. 359, 1915 and El Wld. March 18, 1915.

Electricity in Gases by J. S. Townsend 1915, Oxford.

Extinction of an A-C Arc by J. Slepian, Trans. AIEE 47 p. 1398, 1928.

Extinction of a Long A-C Arc by J. Slepian, Quarterly Trans. AIEE 49 p. 421, April, 1930.

Spray and Fog Tests on 220-kv. Insulators by R. J. C. Wood, Quarterly Trans. AIEE 49 p. 9, January, 1930.

Studies on Sparking in Air by A. Pen-Tung Sah, Trans. AIEE 46 p. 604, 1927.

The Mechanism of Spark Discharge in Air at Atmospheric Pressure by L. B. Loeb, Science, May 17, 1929.

A Sensitive Modification of the Quadrant Electrometer; Its Theory and Use by A. H. and K. T. Compton, Phys. Rev. 14 No. 2 p. 85, Aug., 1919.

Electrical Discharges in Gases by K. T. Compton and I. Langmuir, Rev. Mod. Phys. Apr., 1930 and Apr., 1931.

The Effect of Humidity on Dry Flashover Potential of Pin-Type Insulators by J. T. Littleton and W. W. Shaver, Quarterly Trans. AIEE 47 p. 438, April 1928.

Dielectric Phenomena in High-Voltage Engineering by F. W. Peek, Jr., Third Ed. 1929, McGraw-Hill.

Fundamentals of Electrical Design by A. D. Moore, First Ed. 1927 McGraw-Hill.

Development of a Suspension-Type Insulator by Harold B. Smith Trans AIEE 43 p. 1263, 1924.

Master' Theses of

Geo. K. S. Damos & W. A. Lewis, 1927
J. W. Thatcher, 1930
E. E. Kinney, 1930

will be found in the Library California Institute of Technology.