

PARTICLE SIZES IN A CRYSTALLINE POWDER

THESIS

by

ALFRED ROMER

In Partial Fulfillment of the
Requirements for the Degree of
Doctor of Philosophy

California Institute of Technology
Pasadena, California

1935

PARTICLE SIZES IN A CRYSTALLINE POWDER

Summary

To account for the existence of the structure-sensitive properties of crystals, Zwicky has devised the theory of the secondary structure of crystals. The ideal geometric lattice is overlaid with another, secondary lattice formed by small variations in the ideal lattice, which divides the crystal regularly. The secondary lattice has a lower resistance against slipping than the primary, so that it will fail first when the crystal is worked, and a thorough working may set free blocks having the dimensions of the secondary lattice constants. The size of these particles may be determined by measuring their velocity of fall through a liquid under gravity, and their displacements in Brownian motion. A device was designed for driving a moving picture camera at low speeds and with long picture intervals to make it possible to photograph suspensions of such particles with the ultra-microscope. Preliminary experiments with baryte point to the existence of a set of discrete, permitted sizes for the finest particles obtained by crushing.

Theoretical Background

It has been found convenient to divide the physical properties of crystals into two classes, which Smekal has defined, and to which he has given the names of structure-insensitive and structure-sensitive (1). Structure-insensitive properties are those whose values are the same for all crystals of a given substance, varying little with varying purity, and not greatly changed when the crystal is worked or annealed. Structure-sensitive properties are those whose values are peculiar to the particular crystal used, greatly dependent on purity and greatly altered by small amounts of foreign substances, changing in a single specimen if it is worked or annealed. It is to account for the existence of this group that Zwicky has devised his theory of the secondary structure of crystals (2-16).

A crystal whose elementary particles occupy the points of an ideal geometric lattice, and are so spaced that the energy of the crystal has an extreme value, may be called an ideal crystal (4, 16). It is this structure which is shown by X-ray diffraction experiments, and it is to it that the structure-insensitive properties may be assigned, since in general it is possible to calculate their values from the known properties and arrangement of its elementary particles. In Zwicky's theory, a real crystal differs from an ideal crystal in having a secondary structure, to which the structure-sensitive properties may be assigned,

superimposed upon this primary structure. Many different types of secondary structure are possible, but they may be characterized in general as regularly-recurring, small, local variations in the primary structure of such a nature as to make the free energy of the crystal an absolute minimum, and so give it thermodynamic stability (4).

The structures which Zwicky has described fall into two general classes (7, 11,). In one, the separation of the primary lattice elements is changed in certain evenly spaced regions of the crystal. One or more crystallographic planes, for instance, might be contracted or expanded, or this change in density might occur in a crystallographic line, or even between pairs of the primary elements, one might say in molecules (7, 8,). In the other, a vectorial property, say an electric or magnetic moment, is associated with each of the primary elements, and these vectors are to be lined up within definite regions of a regular size. At the boundaries of these regions, the direction of the vectors will usually change. They may form closed circuits within the crystals, or they may take on some persistent direction and give the crystal a permanent electric or magnetic polarization (10, 11,). In general, the symmetry character of the primary and secondary structure will differ (9, 12,).

In either of these cases, the theory predicts that a crystal will contain sets of standing waves of secondary

structure in all three dimensions, being nearly ideal at the minima of the waves and having the full secondary characteristics at the maxima. If the minima are wide and the maxima fairly abrupt, this will give a set of blocks of regular shape and size, separated by the characteristic planes of the secondary structure. The first type is to be expected for an ionic lattice, and here the change of lattice spacing in the secondary planes will bring their ions out of phase with the ions in the neighboring planes. In the second type, there will be an electrostriction or magnetostriction of the block, which, unless the polarization is parallel to a simple crystallographic plane, will tend to distort the block in such a way as to set up stresses at its boundary. Thus, in both cases, the forces resisting slipping between the blocks will be weaker than those within the ideal lattice, and a crystal may be expected to breakdown first at those boundaries (11). By a thoroughgoing destruction of the crystal, one might hope therefore to separate out some of the blocks created by the secondary structure, and so determine its dimensions.

The secondary spacing will be large compared to the spacing of the primary lattice. Zwicky has estimated it to be of the order of magnitude of 100-10,000 Å.⁰ (4,7), but the exact calculation is difficult, since the secondary structure is to be determined by the cooperative action of a large number of particles (9, 12,) and this introduces

a high degree of complexity into any mathematical formulation. Moreover, for real crystals, the calculation must take into account the existence of a moasic structure (4, 7, 11). The amount of energy involved in the creation of a secondary structure within an ideal crystal is of the same order of magnitude as its thermal energy at the melting point. Accordingly, if a crystal is in a dynamically stable state, it may remain there, even after that state has become thermodynamically unstable, if it lacks the energy to make the transformation, and will remain there unless it is heated to a certain "ignition temperature" to provide that energy. A crystal may easily be thrown into such a state by a sufficient strain either during its formation or afterwards, so that the true secondary structure of a crystal can be predicted only when its thermal and mechanical history is known.

Method of Measurement

Since the size of even the largest particles to be expected approaches the limit of resolution of the microscope, it is necessary to find some indirect method of measurement. There is no lack of such methods, since it is with this range of sizes that the colloidal chemist has been concerned. Svedberg, in his Colloid Chemistry (17) describes a number of these: counting the particles in a known mass, measuring rates of diffusion and sedimentation in liquids, counting the distribution in height after sedimentation equilibrium has been established,

ultrafiltration, observation of the Brownian motion. Many of these methods require a comparatively large amount of the substance, that is a very large number of particles, and a very careful control of the temperature for a matter of hours while the experiment is taking place. It seemed easier, in this case, to adopt a method which would permit observations on individual particles, the measurement of the steady velocity of fall of the particles through a suspending liquid in the field of the ultramicroscope. For this measurement, photographic recording offered a great many advantages over direct visual observation. In addition to the usual photographic advantage, the recording of a large amount of data at once, the low velocity of the particles, and the presence of Brownian motion makes the photographic method distinctly superior. If a slow-moving particle is timed across a measured course, it is difficult to judge the exact instants at which it crosses the marks, but photographs will give the exact positions of the particles at two known instants. Because of the Brownian motion, the actual progress of the particle will be sometimes greater and sometimes less than its average velocity would warrant, and many observations will be needed to average out these fluctuations, more than can be obtained by timing a particle across an ocular grating. Moreover, by the photographic method, the actual position of the particle is recorded, so that not only its velocity, but also its Brownian displacements can be measured, and

two independent determinations of its size can be made. The Brownian displacement can be resolved into two components at right angles, so that there is a theoretical possibility of obtaining information about the shape of the particles.

If a particle is falling freely in an infinite, viscous liquid, its motion will be resisted by a force which will depend on the shape of the particle, and will be proportional to the velocity. This force will increase with the velocity until its sum with the buoyant force of the fluid equals the weight of the particle, when the acceleration vanishes, and the velocity of fall becomes constant. That steady velocity is

$$v = \frac{V(\rho_1 - \rho_2)g}{B} \quad (1)$$

where V is the volume of the particle, ρ_1 its density, ρ_2 the density of the fluid, g the gravitational acceleration, and B a "resistance factor" determined by the shape of the particle.

If a particle has Brownian motion, and if its displacements are measured for a series of equal intervals of time, Einstein has shown that the average of the squares of the displacements

$$\overline{\Delta x^2} = \tau \frac{2kT}{B} \quad (2)$$

where τ is the length of the intervals, k is Boltzmann's constant, and T is the temperature on the absolute scale(18).

The resistance factor B occurs in both of these equations and must be known before they can be used to compute the size of the particles. B , however, is unknown, since we do not know the shape of our particles. In such a case, it is the custom to assume that the unknown particles are spherical, so that $V = \frac{4}{3} \pi r^3$ and $B = 6 \pi \eta r$ where η is the coefficient of viscosity of the fluid. Then equations (1) and (2) reduce to

$$r = \sqrt{\frac{9 \eta v}{2 g (\rho_1 - \rho_2)}} \quad (3)$$

$$r = \frac{k T}{3 \pi \eta \frac{\Delta x^2}{\tau}} \quad (4)$$

Though it is certain that the blocks to be sought in this experiment are not spheres, this practice will be followed for lack of a better, and the radii so computed will at least approximate the true dimensions of the particle.

Both the Brownian motion and the velocity of fall have been studied by two types of measurement. In one, equal intervals of distance are laid off, and the time is measured in which the particle crosses those intervals. In the other, equal intervals of time are established, and the distance travelled in that time is measured. Since the experiments to be described here are of the second type, and since the statistical theory is somewhat different for the two, the present discussion may be limited to that type only, though it must then neglect a great amount of important work.

The Brownian motion has been thoroughly studied both theoretically and experimentally and good reviews of the work have been published (19, 20). Particular mention should be made of a few papers. Von Smoluchowsky has given a general treatment of Brownian motion in a field of force, and has shown that the resultant motion of the particle will be given by the superposition of its Brownian motion on its regular motion in the field (21); in this case, that equations (3) and (4) may be applied independently. Perrin, Chaudesaigues and Dabrowski, working with spherical particles of gamboge and mastic, suspended in water, were able to check Einstein's equation; measuring the diameters of their particles by several different methods (22,23,24). Shaxby, with spherical bacteria suspended in water determined Avogadro's number by the use of Einstein's equation and found 6.08×10^{23} (25). Nordlund made a study of Brownian motion under conditions very similar to those followed in this experiment. He used mercury drops suspended in water and recorded their positions photographically. He computed the radius of the particle from its velocity of fall and applied this value in Einstein's equation. For greater illumination, he used the Zeiss cardioid condenser with its very thin quartz observation cell. To correct for the retarding effect of the walls he used a relation developed by Lorentz and found a value for Avogadro's number of 5.91×10^{23} (26). It would seem then that the validity of this method of

measuring particle sizes has been established.

Preliminary Experiments

The experimental work on this problem was begun by Howell at this Institute (27). In his choice of a working substance he was guided in part by the work of Traube and von Behren, and of Odén. Traube and von Behren observed that when a substance dissolves or crystallizes from solution, it passes through an intermediate stage in which it exists in a swarm of tiny particles. The particles were larger and easier to observe when the substance was chemically complex and of low solubility. Although they did not try barium sulfate, they suggest that its intermediate particles should be of some size (28,29,30). Odén, by a method of mass sedimentation, determined the distribution of particle sizes for a number of barium sulfate precipitates. The crystals were formed under a variety of conditions, and the size and distribution of the particles varied widely, more rapid precipitation producing finer particles. The smallest had calculated radii, assuming them to be spheres, of the order of 0.1μ or smaller. This lower limit is entirely indefinite as Odén's apparatus was not sensitive enough to deal with the most minute particles. In his smallest precipitates, the maximum of the distribution curve fell at a radius of about 0.22μ . Barium sulfate has a special advantage, in addition, for

experiments of this sort, its low solubility. A crystal which has been crushed could be expected to have its solubility increased, so that very small particles might even dissolve entirely. Barium sulfate has a sufficiently low solubility in water to be free from this danger.

For all these reasons, Howell set about to measure the sizes of the particles obtained by crushing natural baryte crystals. With a hand-operated camera he took photographs of aqueous suspensions of the particles in a thin cell mounted in a vertical plane. On his films, he was able to follow eleven particles which he found to be fairly uniform in size, with radii of about 0.26μ . He also found that the Brownian motion was much more lively in the horizontal direction than in the vertical, which led him to believe that his particles might be flat plates settling out with their long axes horizontal.

Description of the Apparatus

For more accurate work, it was clearly necessary to drive the camera automatically, so that the intervals between pictures might be more uniform. It also seemed desirable to make the device as flexible as possible. An old-model, standard, moving picture camera was purchased and a driving mechanism was designed for it under the supervision of Dr. Alexander Goetz.

The shutter of a moving picture camera is a circular

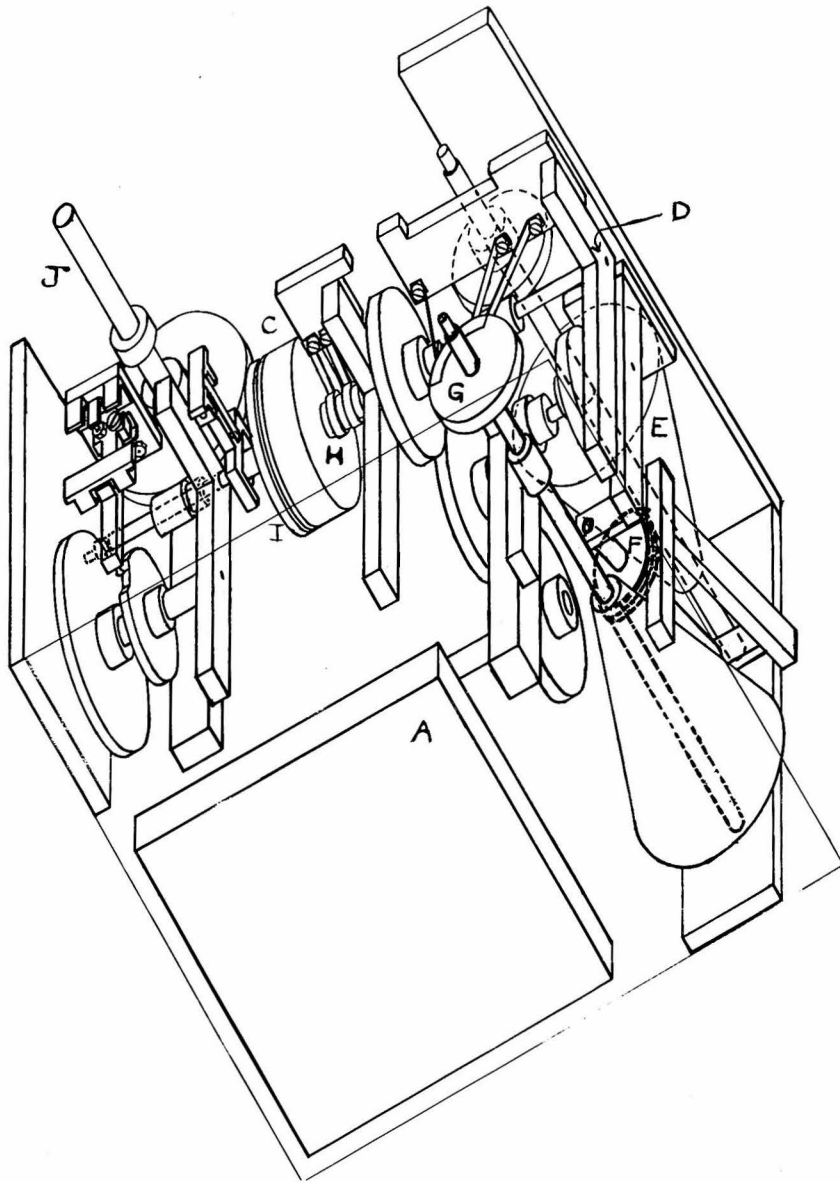

Figure 1
Camera driving device

sector revolving at a constant speed in front of the film, exposing it, and covering it again when it is moved forward. Unless the time of exposure is to be of the same length as the interval between exposures it will be necessary to drive the camera intermittently, that is to devise a mechanism whose driving shaft will make one-eighth of a revolution at a constant speed at regular intervals, since one turn of the camera shaft produces eight pictures. For the sake of compactness both functions, timing and exposure, were given to one motor, the timer energizing a magnetic clutch to connect motor and camera.

A view of the machine is shown in Figure 1. A 1/30 horsepower, shunt-wound, direct current motor, mounted at the back on the square pedestal, A, drives the main shaft, CD, through the train of gears in the center. A worm on this shaft drives the upper, hard rubber cone, E, which through the idler, F, and the lower cone drives the timing disk, G. The idler is a rubber-tired ball-bearing wheel mounted on a 10-32 nut so that it can be screwed back and forth between the cones by a knob projecting from the back of the box. Thus it is possible to change the speed of the timing disk continuously from 1/10 of the speed of the main shaft to 1/250 of it. A separate view of this end of the machine is shown in Figure 2.

The timing disk is made of bakelite with a brass insert which connects together, once a turn, two brushes in series with the clutch magnet, H. This magnet pulls over

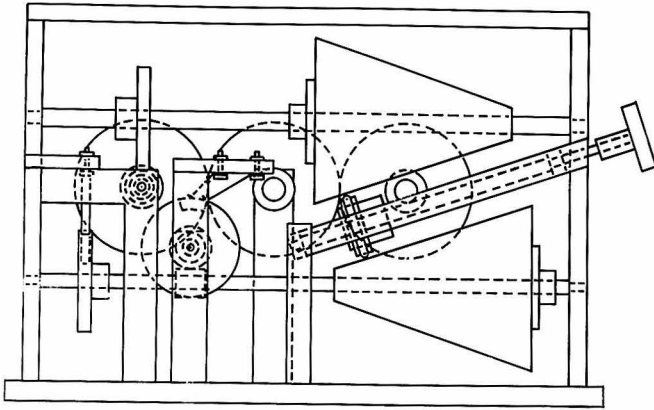

Figure 2

Variable speed drive for timer

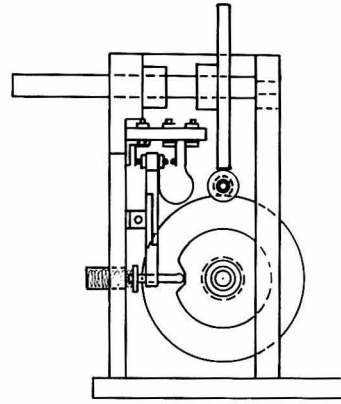

Figure 3

Exposure com

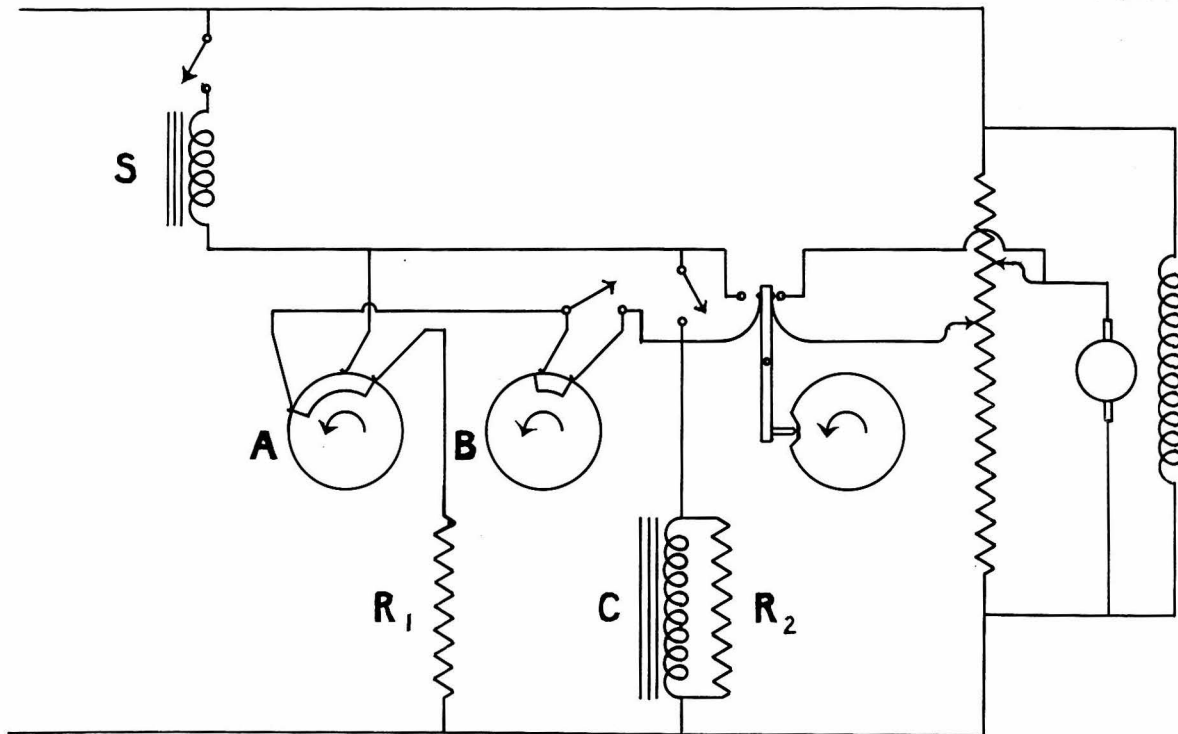

Figure 4

Circuit for driving device

S is the shutter magnet, C the clutch magnet, A and B the timing wheels, R, a 500 ohm resistance for the shutter circuit, R₂ a 500,000 ohm leak for the e.m.f. induced at the break.

the clutch disk, I, and so connects the camera drive with the main shaft. The camera shaft, J, is driven by a worm and worm-gear so chosen that ten turns of the motor are required to make one exposure. Since the speed of the timing disk is variable, its contacts may open, and release the clutch before the exposure is completed. To prevent this, the cam, K, is provided, driven at eight times the speed of the camera shaft, so that it makes one revolution to each exposure. As soon as the camera shaft moves, this cam throws over the switch lever, L, and closes a pair of contacts, short-circuiting the timer until the end of the exposure. A special view of this device is shown in Figure 3.

For longer intervals between pictures, a second timing disk is provided, in series with the first, and driven at $1/20$ of its speed by a worm on the shaft of the lower cone. For short intervals, this disk can be short-circuited by a switch mounted on the back of the driving box. For long intervals, the switch is opened, and the clutch will be energized only when both sets of contacts close, that is, once in twenty turns of the first timing disk. By this means, when the motor is running at full speed, the interval between pictures may be varied continuously between 0.4 second and 200 seconds.

To increase the flexibility of the machine still further, the speed of the motor may be changed automatically during an exposure and restored again to its original

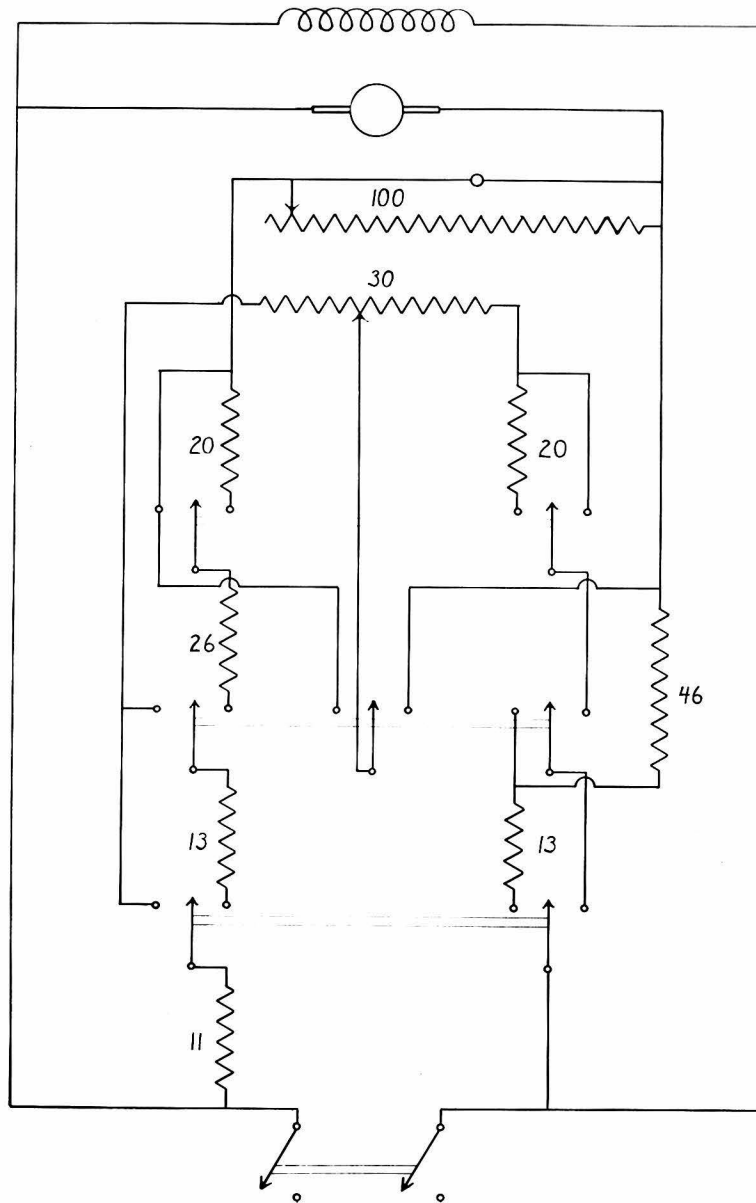

Figure 5

Potential divider for changing the motor speed.

The 30 ohm and 100 ohm rheostats may be inserted at any of the taps of the 70 ohm divider by the three central switches. The potential on the armature is varied by varying the total resistance of the divider between 70 ohms and 100 ohms for the timing interval and increasing it by any amount up to 100 ohms or the exposure. This circuit is completely foolproof, there will be no excessive current for any setting of the switches.

value, so that short exposures may be taken at very long intervals. To do this, the armature and field coils of the motor are disconnected and separately excited, the field coils at a constant potential of 115 volts, the armature at a lower potential supplied by a potential divider. As shown schematically in Figure 4, below the variable contact a portion of the coil is short-circuited by a second pair of contacts on the lever, L. These contacts are normally closed, but when the camera shaft begins to turn and the switch lever is thrown over, they cut in more resistance below the contact, and so increase the potential difference across the armature and the speed of the motor. To make it possible to vary the two motor speeds, interval and exposure, independently, a somewhat more elaborate system is needed, which is shown in Figure 5. Two push-button switches on extension cords are provided for use during an experiment, one to open the magnet circuit and stop the camera, the other to short circuit the timer and drive the camera continuously.

The motor, clutch, and timer are contained in a brass box 5 x 9 x $8\frac{1}{2}$ inches, and mounted with the camera on a special aluminum casting. To deaden vibration as much as possible, the motor is mounted on a cork pad and the whole driving box is screwed to a thick felt pad which is fastened by separate screws to the casting. The camera shaft is set so that the first action of the motor is to open the shutter; the film is moved forward after the exposure so that the vibrations set up then will have time to die

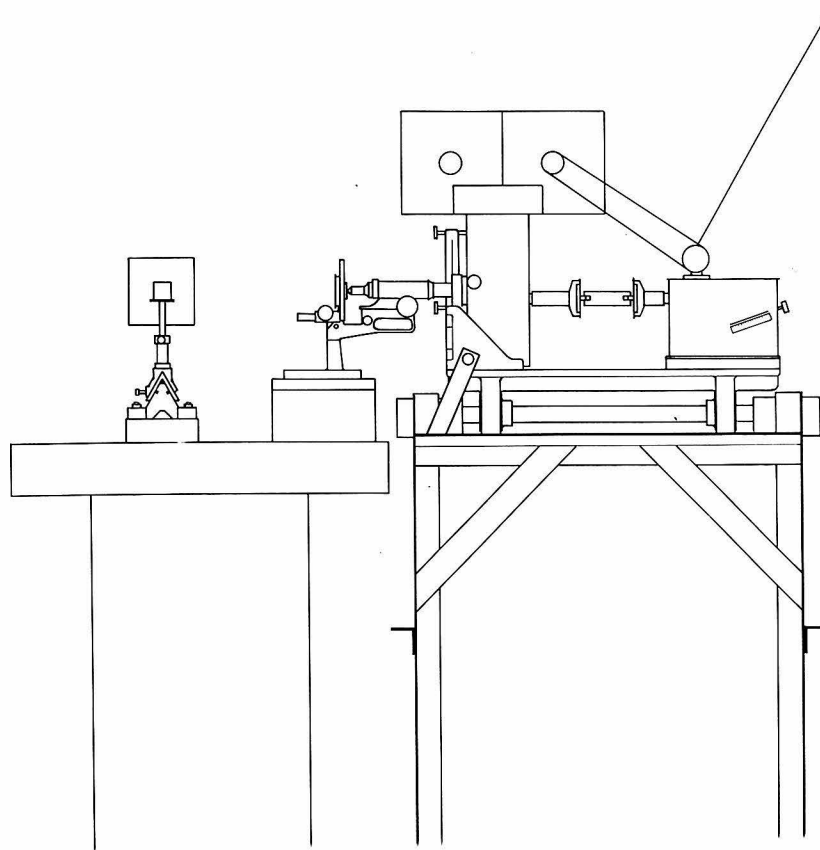

Figure 6

General view of the apparatus

The end of the optical bench with the reflecting prism ~~are~~^{is} at the left, the camera and driving box at the right. On the top of the driving box is a gravity motor for winding up the exposed film.

away before the next picture. The front plate of the camera has a single screw which draws it up against three leveling screws, by means of which the film may be brought into the plane of image. There is a special universal joint in the driving shaft to accommodate this motion. The casting turns about an axle on two ball-bearings so that the camera may be swung clear of the microscope for visual observation. In this work, with the film in a vertical plane, the casting is held up against a stop by a counterweight when the camera is in use. The axle is clamped at each end by three adjusting screws and supported on an A-frame of angle irons bolted to the floor.

Light is furnished by a small, direct current, carbon arc, condensed by a short focus lens and passed through a heat adsorption cell 44 cm. long filled with twice distilled water containing a small amount of copper sulfate. To conserve space, the illuminating system is run at right angles to the axis of the camera, and the light beam turned toward the microscope by internal reflection in a 45° prism. Lamp, cell and prism are mounted on an optical bench. An electromagnetic shutter between cell and prism, operated by the timer, shuts off all radiation from the suspension for about two-thirds of the interval between pictures.

The microscope is set with its stage vertical, and screwed to a wooden box which is clamped to a concrete pier passing through the floor to a separate foundation.

A view of the whole assembly is shown in Figure 6.

To secure the brightest possible illumination, the Zeiss cardioid condenser was used with the special quartz cell designed for it. The objective was the Zeiss "V" glycerin immersion. The image was projected on the film by the eyepiece and, since only one frame of 35 mm. film was available, the projection distance was extremely short. To keep the intermediate image formed by the objective in its normal position, an extension tube was screwed to a Zeiss 3x micrometer eyepiece so that the eye lens could be moved out until a sharp image of the field-of-view stop was thrown on the film. The magnification was about 85. A pair of quartz fibers mounted on the field-of-view stop provided a reference system in the microscope from which the positions of the particles could be measured. As the field of view was dark, these cross hairs were illuminated from the side by light reflected in through a slot in the eyepiece by two galvanometer mirrors.

A microscope cover glass was mounted in the camera in front of the shutter to deflect a small amount of light into a wide-angle photographic objective which served as an eyepiece. With this device, the microscope could be focussed when the camera was loaded, and the subject could be kept under observation during the course of the photography.

Experimental Procedure

Small fragments of natural baryte crystals, 1-3 mm. on edge, were rinsed in concentrated hydrochloric acid to remove soluble surface impurities, then in water, and dried by evaporation. One of these fragments was used for each trial. The crystal was crushed thoroughly in a porcelain mortar with a porcelain pestle and the powder stirred up in 1 ml. of nearly saturated sodium citrate solution to peptize the suspension, then this suspension was diluted with 10 ml. of water (33). Since the smallest particles were the most interesting, it was left to settle for five or ten minutes, then from 0.05 to 0.10 ml. was drawn off the top and diluted with 10 ml. of water. This dilute suspension was given a half hour diffusing period while the camera was being loaded. Then a drop of it was put into the quartz cell, either on the end of a glass rod, or with a small pipette. Most of the particles would attach themselves to the walls of the cell in about the time needed to mount the cell on the stage and focus condenser and microscope, so that it was necessary to search out a region in which there was a sufficient number of moving particles. A new suspension was prepared for each film.

The water used in making up the suspensions, and for all rinsing of glassware was prepared by redistilling the water from an ordinary laboratory supply still from alkaline potassium permanganate solution in a Pyrex flask with a Pyrex condenser tube sealed to it. About twenty small al-

uminum blocks with shallow holes drilled in them were used to prevent bumping (27). This water was kept in Jena glass bottles. The water for each day's trial was brought into the laboratory twenty-four hours before it was to be used, so that when the suspension was made up, it would be at room temperature. This precaution made it safe to assume that the suspension was at room temperature, since the cell was too small for a direct measurement.

From 50 to 80 pictures were taken of each suspension at intervals of from 4 to 7 seconds, with exposures of about 0.2 second. This means that each suspension was kept under observation for 3 to 8 minutes. The exposure interval was measured continually with a stop watch while each film was being made. At the end of a film, the suspension was removed and a stage micrometer having 0.1 mm. divisions was brought up and focussed by the substage rack and pinion, the microscope tube being left in the same position. A drop of immersion fluid was placed between objective and micrometer and five or six pictures of it were taken, giving a separate record of the magnification for each film.

The pictures were projected by a small Leica projector on a sheet of graph paper so that the coordinates of the particles could be read off directly to the nearest 0.5μ . The total magnification was about 750. The procedure finally adopted for identifying the particles was to catalogue all the particles on one picture, then to identify the

fixed particles on a later picture with this catalogue and mark in their positions on the graph paper in red. The moving particles could then be followed through the film in groups of two or three. As the image of each particle was characteristic in shape and size, identification was usually very easy.

Comparison of the images of the micrometer rulings, one of which was always at the edge of the picture, with the lines of the graph paper showed very little curvature of the field. The departure of the projected image from a straight line was of the same order of magnitude as the uncertainty in reading the coordinates of a particle.

Treatment of Data

If there were no Brownian motion, the equation of motion of a particle through the suspension would be

$$y = y_0 - vt \quad (5)$$

where y is the vertical coordinate. Because of the Brownian motion, the actual positions of the particle will fluctuate about the ideal positions, but values can be computed for y_0 and v by the method of least squares. If the ideal values of y are now computed by (5), the departure of the particle from its ideal position can be found at any time. The difference between two successive departures will give the vertical component of the Brownian displacement. The horizontal component is found directly as the

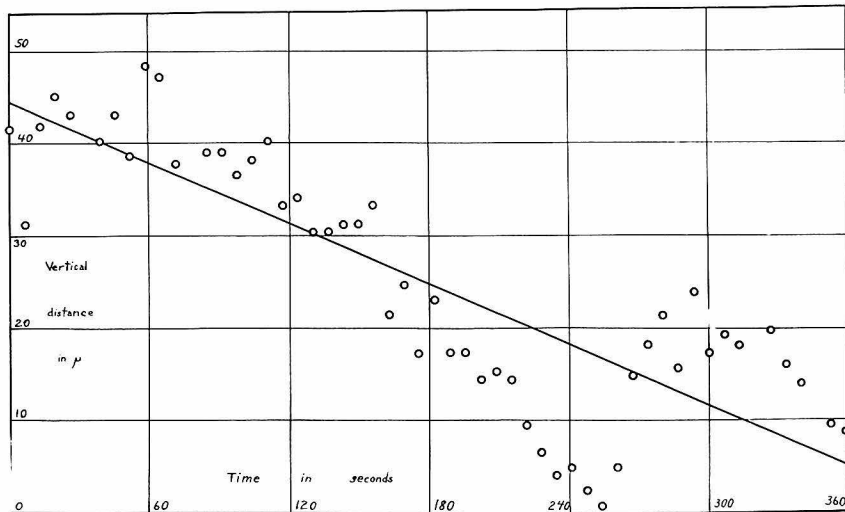

Figure 7

Velocity of fall for particle #9, film #28

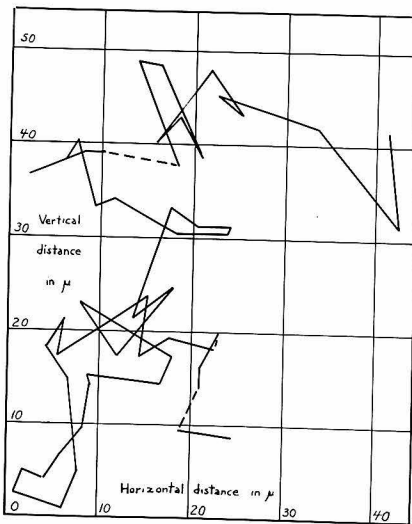

Figure 8

Actual course of particle #9, film # 28

The broken line indicates a gap in the series of one picture on which the particle could not be found.

difference between two successive horizontal coordinates. From this series of values, the mean of the squares of the horizontal and vertical components can be computed, $\overline{\Delta x^2}$ and $\overline{\Delta y^2}$. Figure 7 shows the observed vertical coordinates of a particle plotted against the time. The straight line is the graph of equation (5) for this case. Figure 8 shows the actual course of a particle across the cell.

The value for the velocity is made uncertain by what may be called the diffusion of the particles, a drift either with or against the velocity caused by a preponderance of Brownian displacements in one direction or the other. The error in any value of y is the sum of all vertical displacements up to that time; and since the Brownian displacements have a Gaussian distribution, we can find the probable error of each observation by finding the "probable" Brownian displacement for that time, that is, the displacement which has a probability of one-half. This will be

$$\epsilon_y = 0.4769 \sqrt{2 \frac{\overline{\Delta y^2}}{t} t}$$

where t is the time elapsed since the first observation. Then it becomes possible to compute the probable error of the velocity, which is approximately

$$\epsilon_v = \frac{1.09}{n} \sqrt{\frac{\overline{\Delta y^2}}{t}} \quad (6)$$

where n is the number of observations; if the unit of length is one division of the graph paper and the unit of

time the picture interval.

Three values for the radius of each particle were computed by equations (3) and (4), r_v from its velocity of fall and r_x and r_y from its vertical and horizontal Brownian motion. The probable error of v is known from equation (6), so the probable error of r_v can be computed. Since the Brownian displacements obey a Gaussian distribution law, the probable errors of $\sqrt{\frac{\Delta x^2}{2}}$ and $\sqrt{\frac{\Delta y^2}{2}}$ can be calculated in the same way as the probable error of the probable error. Since r_x and r_y are calculated from the squares of these quantities, their probable errors will be given by

$$\epsilon_r = \frac{0.9358}{\sqrt{n}} r \quad (7)$$

where n is the number of observations.

The density of the particle, ρ_1 , appears in equation (3) and is absent in equation (4). In all the calculations, the value of ρ_1 used was that of baryte, so that r_v will have a false value for particles of a different density. Then, a discrepancy between the values of r_v and r_y may be taken as an indication that the particle in question either is not baryte, or contains a loose clump of baryte particles and so has too large a resistance. Neither type of particle is of interest in this investigation, since r_v varies inversely as the square root of $\rho_1 - \rho$,

$$\frac{r_y}{r_v} = \sqrt{\frac{\rho_1 - 1}{\rho - 1}} \quad (8)$$

where ρ_1 is the density of the baryte and ρ the true density

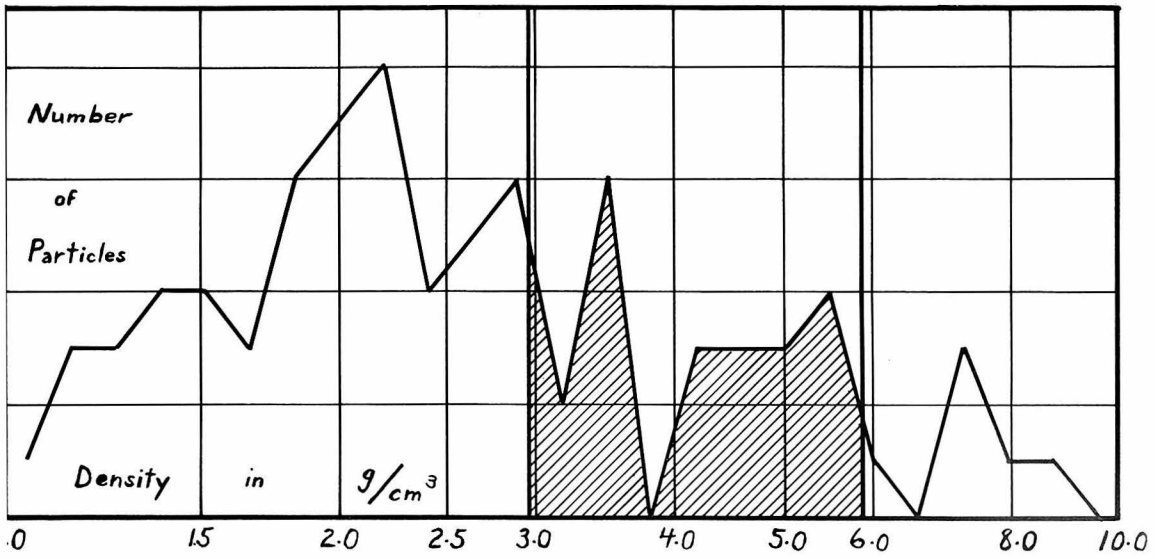

Figure 9

Frequency distribution for particle densities.

of the particle, if the suspending liquid is water. The density for each particle was computed by (8) and a distribution polygon, shown in Figure 9, plotted for the values of $\log_{10}\rho$. The peak between $\rho = 2.0$ and $\rho = 2.5$ is undoubtedly to be attributed to bits of porcelain broken off during the crushing. To eliminate these, and still leave a safe margin, considering the uncertainty in r_y , a particle was considered to be of baryte if its value of $\frac{r_y}{r_v}$ lay between 0.80 and 1.25. Though this excluded three-fourths of the particles observed, it need not seem too stringent when the number of the particles adsorbed on the walls of the cell is considered. It may be assumed that all the baryte particles have similar charges, and if the wall is oppositely charged, nearly all of them will be attracted to it; whereas foreign particles, which may have charges of the same ^{sign} as the wall, will not be so universally attracted. The result will be a suspension rich in contamination and poor in baryte.

The baryte particles are presumed to be negatively charged by the adsorbed citrate ions (33), the cell walls, positively, by hydrogen ions adsorbed from the acid used for cleaning. To reduce the number of operations, and the number of opportunities for contamination, the cell was never dried before use since it was to contain an aqueous suspension. The fixing of the suspension might be avoided then by drying the cell, either by rinsing in alcohol, or, since it is of quartz, in the flame. The sign of the charge

might be reversed by rinsing the cell in an alkaline solution, but the alkali must be kept in a wax bottle to prevent contamination by dissolved glass.

This test retains 22 of the original 90 particles. The results are shown in the tables. Table 1 gives the temperature of the suspension, and the velocity of fall and mean square displacements for each particle, with their probable errors. Table 2 gives the three values for the radius, r_v , r_y , and r_x with their probable errors, and the ratio r_x/r_y . The mean radius, \bar{r} , and its probable error were calculated from r_v and r_y , weighting each by the reciprocal of the square of its probable error.

Interpretation of the Results

It is to be noticed that nine of the eleven smallest particles lie in very close, distinctly separated, groups and that none of the larger ones do. This is what might be expected of particles made up of blocks of a definite size. Among the smaller ones, the addition of a block will make a great difference in size, and particles must have definitely one size or another. Among the larger particles, the addition of a single block will make no great difference, and a particle may have almost any size. A random set of particles might be expected to have a continuous set of separate sizes for the large particles, and separated groups with a small range of sizes for the small ones.

If the dimensions of a particle are all of about the

same size, there is no question but that its Brownian motion will be the same in every direction. However, if one of the dimensions differs greatly from the others, it might be expected that a particle settling down through a liquid would find some preferred orientation. A rod might set its axis in the direction of fall, a plate, its broad side, and in either case, there would be a lower resistance, and a more lively Brownian motion in one direction than in the other. This leaves the rotational Brownian motion out of account, however, and, as calculation shows, it will toss the particle about so that unless it is very asymmetric, it will present its least and its greatest dimensions to every direction in turn, and have, in the average, an equal Brownian motion in all of them. This has also been demonstrated experimentally by Przi Bram with chains of dead bacteria, who found that even for a chain 26 times as long as its diameter, the difference in the two root-mean-square displacements was only about 20 % (19).

Reference to the table will show that for the small particles, there is no greater variation in r_x and r_y than the precision of the measurements warrants. For the larger, there are a few large differences, and there is a slight preference for larger values of r_x than of r_y . This probably arises from the method of observation, for the ideal values of x are known, and the observer will tend to repeat the previous value each time, but the ideal values of y are unknown, and cannot be so easily influenced.

For this reason, a particle made up of two elementary blocks will have a size in this experiment neither equal to nor twice as great as the size of the single block, but intermediate between them. In fact it will take at least four particles to double the apparent size of the unit block. The smallest particles observed in these experiments are probably not the elementary blocks as too many groups appear before the double radius is reached, but the presence of the groups does indicate that they are not much smaller. One very lively particle was observed, which could be followed for only ten pictures, so that there is a great uncertainty in the calculation of its size. If it is accepted as baryte, it may very well be a single secondary block, for its radius is 0.05 or 0.06 μ , about half that of the smallest acceptable particle.

It is certain that there is no great number of unresolved particles present, as might be expected if the crystal is continuously divisible, for they would still scatter light and give a general illumination to the background. Actually the background was very dark, even before the precipitation had occurred.

In the absolute value of the radius, there will be a systematic error as well as the accidental errors treated so far. The error in assuming a spherical shape has already been mentioned, and as this will affect both the volume and resistance factor in equation (1) its direction is not easy to predict. The retarding effect of the walls has been

mentioned in connection with Nordlund's experiment. The cell used in these experiments has a depth of 19μ , and, if his correction formula is used, the error, though of some size for the large particles, will be just appreciable for the small ones. The charge on the particle may also be expected to retard it, since the heavy particle will fall more rapidly than the oppositely charged ions that will be nearest it, and so will experience a backward drag from the electrostatic attraction. Tiselius has shown that if there is a sufficient number of mobile ions of both signs present, this effect can be made very small, since the light ions of the same charge as the particle will move in to take its place (34). These two effects both retarding the particle, will decrease v and so decrease r_v . Since \bar{r} depends mostly on r_v , this means that the particles are probably a bit larger than the sizes reported here.

To sum up, the smallest particles found in the debris of crushed baryte crystals were associated in definite groups, indicating that in this range, only certain discrete sizes are possible, as is predicted by Zwicky's theory of the secondary structure of crystals. The smallest particles on which reliable measurements were made had diameters of about 0.25μ about half the size of Howell's particles. There is some evidence that ~~the~~ particles having diameters as small as 0.1μ may exist, but no evidence that there is any great number of very small particles. These conclusions, however must be regarded as only provisional, in view of the meager-

ness of the data. Many more observations must be made to change them from suspicions into certainties.

Finally, I wish to offer my thanks to those people who have given me help through the course of this research: to Dr. Fritz Zwicky who suggested the problem and has directed the attack on it, to Dr. Alexander Goetz to whom the general plan and much of the detail of the apparatus is due, to the whole staff of the Physics Department Shop who have built most of that apparatus and filled up the gaps left by my ignorance in its design, to those members of the staff of the Institute who have lent me apparatus and facilities, either their own or set aside for particular use, and finally to my wife who has taken an equal part with me in the tedium of the experiments and calculations.

BIBLIOGRAPHY

- (1) Smekal, A.: Zeits. fur Physik 55, 289, 1929.
See also references quoted there:
Mitt. Techn. Versuchsanst Wien 16, 1927.
Zeits. d. Ver. D. Ing. 72, 667, 1928.
Metallwirtschaft 7, 776, 1928.
Zeits. fur Elektrochem. 34, 472, 1928.
- (2) Zwicky, F.: Phys. Zeits. 24, 131, 1923.
- (3) Proc. Nat. Acad. Sci. 15, 253, 1929.
- (4) 15, 816, 1929.
- (5) 16, 211, 1929.
- (6) Phys. Rev. 35, 283, 1930.
- (7) Helv. Phys. Acta 3, 269, 1930
- (8) 4, 49, 1931.
- (9) Proc. Nat. Acad. Sci. 17, 524, 1931.
- (10) Phys. Rev. 38, 1772, 1931.
- (11) 40, 63, 1932.
- (12) 43, 270, 1933.
- (13) 43, 765, 1933.
- (14) Helv. Phys. Acta 6, 210, 1933.
- (15) 7, 294, 1934.
- (16) Rev. Mod. Phys. 6, 193, 1934.
- (17) Svedberg, The.: Colloid Chemistry, 2nd ed. pp. 128-201,
New York, Chemical Catalog, 1928.

- (18) Einstein, A.: Ann. der Physik 17, 549, 1905;
also published in English in:
Einstein, A.: Investigations on the Theory
of the Brownian Movement pp. 1-18, ed. by
R. Fürth, trans. by A. D. Cowper, New York,
Dutton, n. d.
- (19) Przibram, K.: Kinetische Theorie der Gase und Dämpfe,
pp. 690-718, vol. 8, part 2 of the Wien-
Harms Handbuch der Experimentalphysik,
Leipzig, Akademische Verlagsgesellschaft,
1929.
- (20) Svedberg, T.: Colloid Chemistry, 2nd ed. pp. 104-120.
New York, Chemical Catalog, 1928.
- (21) von Smoluchowski, M.: Ann. der Physik 48, 1103, 1915.
- (22) Chaudesaigues : C. R. 147, 1044, 1908.
- (23) Perrin, J. and Dabrowski : C. R. 149, 477, 1909.
- (24) Perrin, J.: Brownian Movement and Molecular Reality,
pp. 59-73, trans. by F. Soddy, London, Taylor
and Francis, 1910.
- (25) Shaxby, J.: Proc. Roy. Soc. 104, 655, 1933.
- (26) Nordlund, I.: Zeits. fur physik. Chem. 87, 40, 1914.
- (27) Howell, L. G.: Diss., California Institute of Technology,
Pasadena, 1930.
- (28) Traube, J. and von Behren, W.: Zeits fur physik. Chem.
138, 85, 1928.
- (29) Traube, J.: Koll. Zeits. 47, 45, 1929.

- (30) von Behren, W. and Traube, J.: Zeits. für physik. Chem.
146, 1, 1930.
- (31) Odén, S.: Koll. Zeits. 26, 100, 1920.
- (32) Sedimentation-Analysis and its Application to
the Physical Chemistry of Clays and Precipitates, pp. 861-909, Colloid Chemistry, ed. by
J. Alexander, vol. 1, New York, Chemical Catalog
1926.
- (33) Nichols, M. L. and Thies, O. J., Jr.: J. Am. Chem. Soc.
48, 302, 1926.
- (34) Tiselius, A.: Koll. Zeits. 59, 306, 1932.

TABLE 1

Film Number	Particle Number	Number of Pictures	Temperature in deg. C.	v in μ /sec.	$\frac{\Delta y^2}{z}$ in μ^2 /sec.	$\frac{\Delta x^2}{z}$ in μ^2 /sec.
28	9	56	23	0.109±0.015	3.74±0.47	3.88±0.49
28	11	28	23	0.111±0.031	3.91±0.70	3.15±0.57
28	14	32	23	0.170±0.022	2.68±0.45	2.77±0.46
31	9	13	25	0.180±0.067	3.09±0.82	3.91±1.03
32	4	80	25	0.220±0.010	3.08±0.33	2.09±0.22
29	10	57	23	0.240±0.011	2.61±0.33	2.46±0.31
28	10	56	23	0.244±0.014	3.05±0.39	2.79±0.35
27	7	55	25	0.268±0.017	3.15±0.40	2.93±0.38
29	1	49	23	0.269±0.012	2.00±0.27	1.45±0.20
29	20	57	23	0.271±0.011	2.56±0.32	2.71±0.34
31	3	77	25	0.317±0.009	2.66±0.29	2.61±0.28
30	3	80	24	0.382±0.008	1.92±0.21	2.27±0.24
28	1	45	23	0.514±0.013	1.58±0.22	1.28±0.18
28	2	20	23	0.630±0.029	1.82±0.39	0.82±0.17
30	8	32	24	0.975±0.015	1.11±0.19	0.54±0.09
30	1	8	24	1.25±0.06	1.37±0.41	0.32±0.11
27	6	12	25	1.38 ±0.05	1.40±0.39	0.79±0.21
31	20	19	25	1.57 ±0.02	1.08±0.24	0.32±0.07
29	19	21	23	1.44 ±0.02	0.77±0.16	0.53±0.11
27	5	20	25	2.09 ±0.03	1.01±0.21	0.44±0.09
27	9	8	25	2.41 ±0.06	0.76±0.26	1.26±0.43
31	1	8	25	3.98 ±0.04	0.59±0.20	0.64±0.22

TABLE 2

Film Number	Particle Number	Number of Pictures	r_v in μ	r_y in μ	r_x in μ	r_x/r_y	\bar{r} in μ
28	9	56	.123 \pm 0.009	.124 \pm 0.016	0.115 \pm 0.013	0.927	.123 \pm 0.008
28	11	28	.124 \pm 0.017	.118 \pm 0.021	0.147 \pm 0.038	1.247	.121 \pm 0.013
28	14	32	.154 \pm 0.010	.173 \pm 0.029	0.167 \pm 0.028	0.965	.156 \pm 0.009
31	9	13	.155 \pm 0.029	.157 \pm 0.041	0.124 \pm 0.033	0.789	.156 \pm 0.024
32	4	80	.171 \pm 0.004	.158 \pm 0.017	0.232 \pm 0.025	1.469	.170 \pm 0.004
29	10	57	.183 \pm 0.004	.184 \pm 0.023	0.187 \pm 0.024	1.017	.183 \pm 0.004
28	10	56	.184 \pm 0.005	.152 \pm 0.019	0.165 \pm 0.021	1.085	.182 \pm 0.005
27	7	55	.188 \pm 0.006	.155 \pm 0.020	0.166 \pm 0.021	1.071	.185 \pm 0.006
29	1	49	.193 \pm 0.004	.230 \pm 0.031	0.316 \pm 0.043	1.372	.194 \pm 0.004
29	20	57	.202 \pm 0.004	.179 \pm 0.023	0.170 \pm 0.021	0.950	.201 \pm 0.004
31	3	77	.206 \pm 0.003	.180 \pm 0.019	0.185 \pm 0.020	1.028	.205 \pm 0.003
30	3	80	.228 \pm 0.002	.246 \pm 0.026	0.208 \pm 0.022	0.845	.228 \pm 0.002
28	1	45	.268 \pm 0.003	.293 \pm 0.042	0.362 \pm 0.051	1.238	.268 \pm 0.003
28	2	20	.296 \pm 0.007	.254 \pm 0.054	0.565 \pm 0.120	2.23	.295 \pm 0.007
30	8	32	.365 \pm 0.003	.415 \pm 0.070	0.852 \pm 0.143	2.03	.365 \pm 0.003
30	1	8	.413 \pm 0.011	.343 \pm 0.116	1.45 \pm 0.48	4.24	.412 \pm 0.011
27	6	12	.427 \pm 0.008	.348 \pm 0.096	0.616 \pm 0.170	1.771	.427 \pm 0.008
31	20	19	.457 \pm 0.003	.450 \pm 0.099	1.49 \pm 0.33	3.24	.457 \pm 0.003
29	19	21	.488 \pm 0.003	.601 \pm 0.125	0.876 \pm 0.182	1.458	.488 \pm 0.003
27	5	20	.525 \pm 0.003	.481 \pm 0.102	1.12 \pm 0.24	2.32	.525 \pm 0.003
27	9	8	.565 \pm 0.007	.644 \pm 0.217	0.388 \pm 0.131	0.602	.565 \pm 0.007
31	1	8	.728 \pm 0.004	.815 \pm 0.274	0.755 \pm 0.254	0.926	.728 \pm 0.004